

**INVITATION FOR BIDS
AND
CONSTRUCTION DOCUMENTS
FOR**

**JOB NO. 19-03
Makaleha On-Site Sodium Hypochlorite Generation
Pilot Project
KAUA'I, HAWAII**

October 2018

**DEPARTMENT OF WATER
COUNTY OF KAUA'I
LIHU'E, KAUA'I, HAWAII**

APPROVED:



Manager and Chief Engineer

10/11/18

Date

1 ADMINISTRATION

1.1 INVITATION FOR BIDS.

DEPARTMENT OF WATER, COUNTY OF KAUAI
19-03 Makaleha On-Site Sodium Hypochlorite Generation Pilot Project
KAUAI, HAWAII

Pursuant to Chapter 103D, HRS, SEALED TENDERS will be received up to and opened at 12:00 p.m., Hawaiian Standard Time (HST) on **Thursday, November 15, 2018**, in the Administration Office of the Department of Water at 4398 Pua Loke Street, Lihu'e, Kaua'i, Hawai'i ("DOW Admin. Office"). Bids received after the date and time specified above shall be rejected. Facsimile offers will not be accepted or considered.

The schedule set out below represents the Department's best estimate of the schedule that will be followed for this competitive sealed bidding procurement process. If an activity in the schedule is delayed, the dates following the delayed activity may be adjusted by the same number of days. All prospective Offerors will be advised by addendum of any changes to the Procurement Schedule.

Activity	Scheduled Date
Invitation For Bids Issued	10/11/18
Pre-Bid Conference	10/24/18
Deadline: Receipt of Questions / Comments / Material Substitutions	10/31/18
Deadline: Notice of Intent	Not Applicable
Department's Responses to Questions / Comments / Material Substitutions	11/07/18
Bid Opening	11/15/18
Selection / Award Notification	11/21/18
Contract Execution Period	11/28/18
Contract Tentative Notice to Proceed Date	12/20/18

The Manager and Chief Engineer also reserves the right to reject any or all bids, in whole or in part, if deemed to be in the best interest of the Department of Water.

All bids shall be submitted via www.publicpurchase.com. Bids must be signed in ink by the person or persons duly authorized to sign bids in the space provided for signature on the Offer form.

BIDDERS ARE HEREBY NOTIFIED THAT EVIDENCE OF THE AUTHORITY OF THE PERSON(S) SIGNING THE BID DOCUMENT IS REQUIRED TO BE INCLUDED WITH THE BID DOCUMENTS. FAILURE TO COMPLY WITH THIS REQUIREMENT WILL BE CAUSE FOR REJECTION OF THE BID AS BEING NON-RESPONSIVE.

SCOPE OF WORK: Furnish, assemble and provide start-up/testing of an on-site sodium hypochlorite generation (OSG) system of the type specified herein, in place complete, as shown on the contractor's drawings. The OSG shall be installed at the Department's Makaleha Water Treatment Facility. This OSG system will be bid as a complete system. All components associated

Job No. 19-03

Makaleha On-Site Sodium Hypochlorite Generation Pilot Project



with the OSG unit, as specified herein, shall also be furnished by the OSG unit manufacturer or its regional representative. The OSG unit manufacturer or regional representative shall also furnish the sodium hypochlorite storage tank level transmitter as specified, as indicated in the contract drawings and specifications.

PLANS AND SPECIFICATIONS: The contract documents are to be downloaded electronically. Please email the Department of Water Deputy Secretary, Christine Erorita at cerorita@kauaiwater.org for instructions. May be examined and obtained at the DOW Admin. Office. Those who download documents electronically shall be responsible for any and all costs related to printing or reproducing the items as required for offer submission. For inquires on obtaining plans and specifications and all other inquires call the project engineer at (808) 245-5436.

The contract documents may be examined at the following locations:

DOW Admin. Office, Līhu`e, Kaua`i, Hawai`i

Published in: Garden Island Newspaper
 Bid Service Weekly
 General Contractors' Association
 State Procurement Internet website at: <https://hands.ehawaii.gov/hands/welcome>
 DOW website at: www.kauaiwater.org
 DOW electronic procurement system at: www.publicpurchase.com

CONTRACTORS LICENSE: All prospective Bidders must be currently licensed by the State of Hawai`i, Department of Commerce and Consumer Affairs, Division of Professional and Vocational Licensing.

“A” general engineering contractors and “B” general building contractors are reminded that due to the Hawai`i Supreme Court’s January 28, 2002 decision in *Okada Trucking Co., Ltd. v. Board of Water Supply, et al*, 97 Haw. 450 (2002), they are prohibited from undertaking any work, solely or as part of a larger project, which would require the general contractor to act as a specialty contractor in any area where the general contractor has no license. Although the “A” and “B” contractor may still bid on and act as the “prime” contractor on an “A” or “B” project (See, HRS § 444-7 for the definitions of an “A” or “B” project), respectively, the “A” and “B” contractor may only perform work in the areas in which they have the appropriate contractor’s license (An “A” or “B” contractor obtains “C” specialty contractor’s licenses either on its own or automatically under HAR § 16-77-32.). The remaining work must be performed by appropriately licensed entities. It is the sole responsibility of the contractor to review the requirements of this Project and determine the appropriate licenses that are required to complete the Project.

PRE-BID CONFERENCE: A non-mandatory Pre-Bid Conference will be held at the Project site, as indicated on the attached map. If a Pre-Bid Conference is held, all potential interested offerors, subcontractors, and union representatives are invited to attend on the date specified in the Procurement Schedule in Section 1.1 at the DOW Admin. Office. A visit to the site will be conducted following the meeting. The site inspection is not mandatory; however, submission of an offer shall be evidence that the Offeror understands the scope of the project and shall comply with

the specifications herein, if awarded the contract and has thoroughly familiarize itself with the existing conditions, rules and regulations, and the extent and nature of work to be performed. No additional compensation, subsequent to bid opening, shall be allowed by reason of any misunderstanding or error regarding site conditions or work to be performed. All prospective Bidders must make their own transportation arrangements to and from the site. Those interested in attending the pre-bid conference should contact the Procurement Officer. Offerors are advised that anything discussed at the pre-bid conference does not change any part of this solicitation. All changes and/or clarifications to this solicitation shall be done in the form of written addenda.

NOTICE OF INTENTION TO BID: Bidders are not required to submit a Notice of Intent to Bid.

MANAGER AND CHIEF ENGINEER
DEPARTMENT OF WATER
COUNTY OF KAUAI

TABLE OF CONTENTS

1 ADMINISTRATION..... 2

1.1 INVITATION FOR BIDS..... 2

1.2 DEFINITIONS..... 7

1.3 INSTRUCTIONS TO BIDDERS..... 9

1.4 GENERAL PROVISIONS, SPECIFICATIONS, AND STANDARD DETAILS..... 16

1.5 PROCUREMENT OFFICER AND CONTRACT ADMINISTRATOR..... 17

2 SCOPE OF WORK..... 19

2.1 SCOPE OF WORK..... 19

2.2 TIME OF COMPLETION..... 24

2.3 PERMITS..... 24

**2.4 CONTRACTOR’S RESPONSIBILITY FOR EXISTING UTILITIES AND
STRUCTURES..... 25**

2.5 POWER AND WATER SUPPLIES..... 25

2.6 CONTRACTORS LICENSE REQUIRED..... 25

2.7 HOURS..... 25

2.8 QUANTITIES..... 25

2.9 MATERIALS FURNISHED FOR THE PROJECT..... 26

2.10 WORK TO BE DONE WITHOUT DIRECT PAYMENT..... 26

2.11 INTENT OF THE SPECIFICATIONS..... 26

2.12 IMPLEMENTATION..... 26

2.13 GOVERNING LAW; APPLICATION OF LAW..... 26

3 METHOD OF AWARD..... 27

3.1 METHOD OF AWARD..... 27

3.2 HAWAI‘I REVISED STATUTES..... 27

3.3 RESPONSIBILITY OF SUCCESSFUL BIDDER..... 27

3.4 REQUIREMENT FOR AWARD..... 29

3.5 TIMELY SUBMISSION OF ALL CERTIFICATES..... 29

3.6 FINAL PAYMENT REQUIREMENTS..... 30

4 AWARD OF CONTRACT AND NOTICE TO PROCEED..... 31

4.1 AWARD..... 31

4.2 NOTICE OF AWARD..... 31

4.3 NOTICE TO PROCEED..... 31



APPENDIX A: SAMPLE CONTRACT. (BOUND SEPARATELY)..... 32
APPENDIX B: GENERAL PROVISIONS FOR CONSTRUCTION CONTRACTS FOR THE DEPARTMENT OF WATER, DATED APRIL 25, 2016 (BOUND SEPARATELY)..... 33
APPENDIX C: OFFER. 34
APPENDIX D: INSURANCE. (BOUND SEPARATELY)..... 48
APPENDIX E: WAGE CERTIFICATE FOR SERVICE CONTRACTS 49
APPENDIX F: CERTIFICATION OF COMPLIANCE FOR FINAL PAYMENT. 50
APPENDIX G: SPECIAL PROVISIONS. 51



1.2 DEFINITIONS.

This section shall incorporate the definitions not listed below and contained in Hawai‘i Revised Statutes (HRS) 103D; the Hawai‘i Administrative Rules (HAR), Title 3, Department of Accounting & General Services, Subtitle 11, Procurement Policy Board, Chapters 120 through 131; and the General Provisions for Construction Contracts of the Department of Water, dated April 25, 2016. Terms as used in this solicitation, unless the context requires otherwise, shall have the following meaning:

“Award” means the notification of the Department’s acceptance of a bid or the presentation of a contract to the selected offeror.

“Bid sample” means a sample to be furnished by a bidder to show the characteristics of the item offered in the bid.

“Board” or “Board of Water Supply” shall mean the “Department of Water, County of Kaua‘i”, as provided for in the County Charter which became effective January 2, 1969.

“Contract Administrator” means the person designated to manage the various facets of the Contract to ensure the Contractor’s total performance is in accordance with the contractual commitments and obligations to the Department are fulfilled.

“Department” or “DOW” means the Department of Water, County of Kaua‘i, contracting on behalf of the Board of Water Supply. Wherever the terms “Engineer” or “Owner” are used in any document which forms a part of the Contract, the terms shall mean the Department of Water, County of Kaua‘i and its authorized agents.

“Offer” means the bid, proposal, or quotation.

“Offeror” means any individual, partnership, firm, corporation, joint venture, or other legal entity submitting, directly or through a duly authorized representative or agent, an offer for the good, service, or construction contemplated.

“Opening” means the date set for opening of bids, receipt of unpriced technical offers in multistep sealed bidding, or receipt of proposals in competitive sealed proposals.

“Procurement officer” means any person with delegated authority to enter into and administer contracts and make written determination with respect thereto. The term includes an authorized representative acting within the limits of authority. The delegated authority is received from the chief procurement officer directly or through the head of a purchasing agency or designee to the procurement officer.

“Project” means work to be performed as set forth in the Contract, including furnishing all services, labor, goods, materials, supplies, equipment and other incidentals reasonably necessary for the successful completion of work contemplated under the Contract.

“Quotation” means a statement of price, terms of sale, and description of goods, services, or construction offered by a prospective seller to a prospective purchaser, usually for purchases pursuant to section 103D-305, HRS.

“Special Provisions” means the terms and conditions pertaining to the specific solicitation in which they are incorporated; including but not limited to terms and conditions describing the preparation of solicitations, evaluation of offers, determination of award, plus those applicable to performance by the Contractor.

Additions or revisions to the General Provisions, which shall be considered a part of the General Provisions, setting forth conditions or requirements applicable to the particular project or contract under consideration shall be included in the Special Provisions. Should any Special Provisions conflict with these General Provisions, said Special Provisions shall govern.

“Specifications” mean any description of the physical or functional characteristics, or of the nature of a good, service, or construction item. The term includes descriptions or any requirement for inspecting, testing, or preparing a good, service, or construction item for delivery.

“Standard commercial product” means a product or material, in the normal course of business, is customarily maintained in stock or readily available by a manufacturer, distributor, or dealer for the marketing of the product.

“Successful bidder” means the individual, partnership, firm, corporation, joint venture, or other legal entity that submitted a bid for the Project and was determined to be a responsible, responsive bidder and selected for award of the contract.

1.3 INSTRUCTIONS TO BIDDERS.

THESE INSTRUCTIONS TO BIDDERS SHALL BE CONSIDERED TO BE INCORPORATED INTO THE SPECIAL PROVISIONS.

1.3.1.1 Submission of Bids: Bidders shall read and examine the Special Provisions, Specifications, General Provisions and all other bid documents attached hereto and by reference made a part hereof. Submission of bids shall be deemed a verification of such reading and examination and shall be deemed acknowledgement and agreement to be bound by the terms and conditions, and specifications of such documents. Bidders must deposit their bid envelopes at the DOW Admin. Office, prior to the designated date and time as specified in the bid documents. All bid envelopes must bear the Department time stamp mark. Envelopes without the said mark or time stamped after the bid opening time and date specified in the solicitation will be rejected. All Bidders shall complete and submit with its bid, the Offer form found in Appendix C.

All bids for the construction of this project “Job No. 19-03 Makaleha On-Site Sodium Hypochlorite Generation Pilot Project” shall be submitted via www.publicpurchase.com

1.3.1.2 Bidding Instructions: In addition to these Instructions to Bidders, Bidders are directed to SECTION 2 - BIDDING / PROPOSAL INSTRUCTIONS of the “GENERAL PROVISIONS FOR CONSTRUCTION CONTRACTS OF THE DEPARTMENT OF WATER”, dated April 25, 2016 (hereafter “GENERAL PROVISIONS”), and the General Provisions in its entirety.

1.3.1.3 Offer Form: The attached form of the OFFER is furnished only for the guidance of bidders and is not to be used for actual bidding. An official copy of the Offer on which the bid shall be made will be furnished to the prospective bidder when plans and specifications are obtained.

1.3.1.4 Omission or Erasures; Conditioned Offers: Any Offer which contains any omission or erasure or alteration not properly initialed or any attempt by a bidder to condition the bid or other irregularity, and bid samples or descriptive literature, unless expressly requested, will not be examined or tested, and will not be deemed to vary any of the provisions of this solicitation and are submitted at the Bidder’s risk and may be rejected. Offerors shall not submit their organization’s terms and conditions, standard contracts, or other similar agreements or forms. General reference to such items or attempts to substitute such items for the Department’s **shall** result in the disqualification of the Offeror’s bid as conditioned.

1.3.1.5 Solicitation Review; Submission of Questions and Requests For Clarification:

- 1.3.1.6 Submission of Questions and Requests for Clarification: Offerors are encouraged to submit written questions pertaining to this solicitation. Questions and requests for clarification must be submitted in writing via e-mail or received by post mail to the Procurement Officer not later than the date specified in the Procurement Schedule in Section 1.1 in order to generate an official answer. All written questions will receive an official written response from the Department and become an addenda to this solicitation. The only official position of the Department is that which is stated in writing and issued in this solicitation as an addenda thereto. All other means of communication, whether oral or written, shall not be formal or official responses/statements and may not be relied upon.
- 1.3.1.7 Solicitation Review: Offerors should carefully review this solicitation for defects and/or ambiguities. Comments concerning defects and questionable or objectionable matter must be made in writing either via e-mail or post mailed and should be received by the Procurement Officer not later than the date specified in the Procurement Schedule in Section 1.1. This will allow issuance of any necessary amendments to this solicitation. It will also assist in preventing the opening of offers upon which award may not be made due to a defective solicitation package.
- 1.3.1.8 Standard Questionnaire and Financial Statement: When the Manager and Chief Engineer requires a prospective bidder to file a “Standard Qualification Questionnaire for Prospective Offerors on Department of Water Contracts,” the prospective bidder shall return a completed Standard Questionnaire, on the form provided by the Department, at least 48 hours prior to opening of bids. If this proves satisfactory, the bidder’s Offer will be received.
- 1.3.1.9 Bid Bond: A bid bond for the value of 5% of the total bid value shall accompany the bid.
- 1.3.1.10 Responsibility of Bidders to Study Site: At the time of opening of bids, the Department shall presume that each Bidder has inspected the project site(s) and has read the Plans, Specifications, and other Contract Documents, including all Addenda and has become thoroughly familiar with them. The failure or omission of any Bidder to receive or examine any form, instrument, or document shall in no way relieve that Bidder from any obligation under the Bid or the Contract.

Each bidder must form an opinion of the character of the work and of the materials to be excavated, from an examination of the project site(s), from studies and inspection of available samples, records and reports and from any other investigations the Bidder may wish to make. Each Bidder must form an independent opinion of all the conditions affecting the work to be done and the labor and materials to be supplied, in order to make a Bid in sole reliance thereupon. Failure of a Bidder to become completely familiar with the labor and construction conditions under which the work is to be performed will not relieve

that Bidder of any obligations to furnish all materials, equipment, and labor necessary to perform the work as set forth in this solicitation and to perform the Contract.

1.3.1.11 Insurance: Contractor shall procure and maintain, on a primary basis and at its sole expense, at all times during the life of the contract insurance coverages, limits, including endorsements as described Appendix “D” - Insurance, against claims for injuries to persons or damages to property which may arise from or in connection with the performance of the work by the Contractor or the Contractor’s agents, representatives, employees, or subcontractors. The requirements contained therein, as well as the Department’s review or acceptance of insurance maintained by the Contractor is not intended to and shall not in any manner limit or qualify the liabilities or obligations assumed by the Contractor. Unless otherwise approved by the Manager and Chief Engineer, the policy or policies of insurance maintained by the Contractor shall provide the minimum limit(s) and coverage(s) as specified in the attached Appendix “D” - Insurance and be placed with an insurance carrier authorized to do business in this state and rated A-VII by A.M. Best.

1.3.1.12 Tax Clearance: See: Subsection 3.5 - RESPONSIBILITY OF OFFERORS AND TAX CLEARANCE of the GENERAL PROVISIONS in its entirety. Further, the Bidder shall be required to submit a tax clearance with the bid Offer. Failure to comply with this provision will be grounds for disqualifying the Bidder. The successful bidder will also be required to submit a current valid tax clearance prior to final payment for this Project.

1.3.1.13 Preferences: The following preferences are applicable when preceded by a checked box. Information and legal and procedural requirements pertaining to all preferences can be found within the General Provisions:

Hawai‘i Products Preference (See: Appendix C). Pursuant to HRS 103D-1002, Offers should complete the Certificate of Hawai‘i Products Preference for application of this preference.

Reciprocal Preferences: Pursuant to the provisions of Section 103D-1004, HRS and Subchapter 3, Chapter 124, Subtitle 11, Title 3, HAR, the Manager may impose a reciprocal preference against Bidders from those states which apply preferences.

Recycled Products Preference. Pursuant to HRS 103D-1005, Offerors should contact the Procurement Officer for application of this preference.

Tax Payer Preference (Hawai‘i Excise and Use Tax Preference). Pursuant to HRS 103D-1008, any “taxpaying bidder” shall qualify for this preference.

Qualified Community Rehabilitation Programs Preference. Pursuant to

HRS 103D-1009, a five per cent preference shall be given to services to be provided by nonprofit corporations or public agencies operating qualified community rehabilitation programs in conformance with criteria established by the DLIR for all competitive sealed bid and proposal procurements.

Apprenticeship Program Preference (See: Appendix [Click here to enter text.](#)). Pursuant to HRS 103-55, applicable to public works projects with estimated values of \$250,000 or greater. Section 103-55.6, HRS, as enacted by S.B. 19, Act 17, SLH 2009, and the State of Hawai'i Comptroller's Memorandum 2011-06 as amended, provides for a Hawai'i Apprenticeship Preference for public works construction projects with estimated values of \$250,000 or greater. The preference shall be in the form of five percent (5%) bid adjustment applied to the Bidder's Offer amount.

Safety and Health Program (See: Appendix [Click here to enter text.](#)). Pursuant to HRS 396-18, applicable to construction projects where the offer amount is in excess of \$100,000.

1.3.1.14 Tax Adjustment for Out-Of-State Vendors and Tax Exempt Bidders: Pursuant to the provisions of Section 103-53.5, HRS, where the Bidder is an out-of-state vendor not doing business in the State of Hawaii, or is a person exempted from paying the applicable general excise tax, the package bid or purchase price, for the purpose of determining the lowest price bid, shall be increased by the applicable retail rate of general excise tax and the applicable use tax. The lowest responsible bidder who satisfies all of the requirements of these bid documents, taking into consideration the above increases, shall be awarded the contract, but the contract amount of any contract awarded shall be the amount of the bid offered and shall not include the amount of the increase.

1.3.1.15 Worker's Compensation Act: The Contractor will be required to comply with the provisions of Chapter 97, Revised Laws of Hawaii 1955, known as the "Worker's Compensation Laws," and all laws amendatory thereof, relating to the compensation of employees for personal injuries sustained in the course of their employment. The Contractor's surety or sureties shall be liable for any loss caused the Department by reason of the Contractor's failure to comply with the provisions of said laws.

The Contractor shall furnish to the Department one copy of certificate of said insurance prior to commencement of work. Refer to the "RESPONSIBILITY OF SUCCESSFUL BIDDER" for additional requirements.

1.3.1.16 Subcontractor: Under the terms of this Contract, no subcontractor will be recognized. All subcontractors shall deal directly with the general Contractor;

however, each and every subcontractor shall manage and take care of its own material and waste.

1.3.1.17 Listing Joint Contractors or Subcontractors:

Bidder shall complete the “[Joint Contractors or Subcontractors List](#).” It is the sole responsibility of the bidder to review the requirements of this Project and determine the appropriate specialty contractor licenses that are required to complete the Project.

Bidder shall specify the name of each person or firm to be engaged by the Bidder as a joint contractor or subcontractor in the performance of the contract and the nature and scope of the work to be performed by each regardless of the percentage of the value of the work to be performed by the joint contractor or subcontractor. (HRS 103D-302(b))

Failure of the Bidder to provide the correct names and specialty contractor’s nature of work to be performed may cause the bid to be rejected.

Bidder agrees the completed listing of joint contractors or subcontractors is required for the Project and that Bidder, together with the listed joint contractors and subcontractors, have all the specialty contractor licenses to complete the work.

Based on the Hawai‘i Supreme Court’s January 28, 2002 decision in Okada Trucking Co., Ltd. v. Board of Water Supply, et al., 97 Hawai‘i 450 (2002), the bidder as a general Contractor (‘A’ or ‘B’ license) is prohibited from undertaking any work solely or as part of a larger project, which would require the bidder (‘A’ or ‘B’ general Contractor) to act as a specialty (‘C’ license) Contractor in any area in which the bidder (‘A’ or ‘B’ general Contractor) has no specialty Contractor’s license. Although the ‘A’ and ‘B’ Contractor may still bid on and act as the “Prime Contractor” on an ‘A’ and ‘B’ project (See: HRS § 444-7 for the definitions of an ‘A’ and ‘B’ project.), respectively, the ‘A’ and ‘B’ Contractor may only perform work in the areas in which they have the appropriate Contractor’s license. The bidder (‘A’ or ‘B’ general Contractor) must have the appropriate ‘C’ specialty Contractor’s licenses either obtained on its own, or obtained automatically under HAR §16-77-32.

General Engineering ‘A’ Contractors automatically have these ‘C’ specialty contractor licenses: C-3, C-9, C-10, C-17, C-24, C31a, C32, C-35, C-37a, C-37b, C-38, C43, C49, C-56, C-57a, C-57b, and C61.

General Building ‘B’ Contractors automatically have these ‘C’ specialty contractor licenses: C-5, C-6, C-10, C-12, C-24, C-25, C31a, C32a, C42a, and C-42b.

1.3.1.18 Instructions to complete the Joint Contractors or Subcontractors List:

1.3.1.18.1 Describe the nature of work to be performed by the specialty contractor for this Project and provide the complete firm name of the joint contractor or subcontractor in the respective columns. If the bidder is a general contractor and providing the work of the required specialty contractor, fill in the Bidder's (general contractor's) name and nature of work to be performed for this Project.

1.3.1.18.2 List only one joint contractor or subcontractor per required specialty contractor classification.

1.3.1.18.3 For projects with alternate(s), fill out the respective "Joint Contractors or Subcontractors List for the Alternate(s)." Bidder shall describe the nature of work to be performed by the specialty contractor on this Project for the respective alternate. Bidders shall fill in the complete firm name and nature of work to be performed by the respective joint contractor or subcontractor. If the joint contractor or subcontractor was previously listed under base bid, listing under Alternate(s) is not required.

1.3.1.19 Wages and Labor Requirements: Pursuant to HRS Section 103-55, each bidder submitting an offer and list of subcontractors certifies that: WAGES: The service to be rendered shall be performed by employees paid not less than wages paid to public officers and employees for similar work; and COMPLIANCE WITH LABOR LAWS: All applicable laws of the Federal and State governments relating to workmen's compensation, unemployment compensation, payment of wages, and safety will be fully complied with. The successful Bidder shall complete the Wage Certification in Appendix E.

In accordance with HRS Section 104-2 et seq., the Hawaii Director of Labor and Industrial Relations determines the prevailing wages applicable to the project. The wage rates are the minimum rates to be paid and may be revised. Contractors shall pay the applicable rates, as revised, at no cost to the Department. This is not a representation that labor can be obtained at these rates. It is the responsibility of bidders to inform themselves of local labor conditions and prospective changes or adjustments of wage rates. No increase in the contract price shall be allowed or authorized on account of the payment of wage rates in excess of those listed herein. Wage rate schedules are available at the office of the Department of Labor and Industrial Relations, State of Hawai'i.

Current Wage Rate Bulletin: 492

1.3.1.20 Asbestos Cement Pipe: For all construction contract bids involving asbestos cement pipe, the Contractor shall remove, handle, and dispose of asbestos cement pipe in conformance with all applicable OSHA, State, and Federal regulations. The asbestos cement pipes shall only be disposed of at an approved disposal site.

- 1.3.1.21 Chlorination Subcontractor: All construction contract bids involving any chlorination work shall have a name listed for the C-37d Water Chlorination Subcontractor. Any bid not listing this subcontractor shall be rejected and disqualified.
- 1.3.1.22 Substitute Materials: Bidders contemplating submission of bids based on substitute materials must obtain prior written permission from the Department. Lists of substitute materials together with qualifying data shall be submitted on the Department's Request for Substitution form by the date set in the Procurement Schedule in Section 1.1, as evidenced by the time stamp of the Department, to the Procurement Officer for approval (the Request for Substitution form may be obtained from this individual). It is not the intent of the Department to exclude or limit the products. Any substitute material determined by the Department upon evaluation to be an acceptable equal, will be listed in an addendum to this solicitation, issued prior to the bid opening date. The Department is the sole judge as to the comparable quality and suitability of any substitute material and its decision shall be final. If a Bidder offers a product without the Department's pre-approval, the substitute material shall not be considered for award.
- 1.3.1.23 Independent Price Determination: By submitting a bid, the bidder certifies that the price submitted was independently arrived at without collusion.
- 1.3.1.24 Protests: Any protest shall be submitted in writing within five (5) working days after the posting of the notice of award; provided that a protest based upon the contents of the solicitation shall be submitted in writing prior to the date set for the receipt of offers. Any and all protests pursuant to Hawai'i Procurement Code, Chapter 103D-701 HRS and Section 3-126-3 HAR shall be submitted in writing to the Procurement Officer for this solicitation.
- 1.3.1.25 Incorporation By Reference: Bidders hereby agree that all documents referred to in the Table of Contents are hereby incorporated by reference into this solicitation.
- 1.3.1.26 Severability: If any covenant, condition, or provision of this solicitation is held to be invalid by any court of competent jurisdiction, such holding shall not affect the validity of any other covenant, condition, or provision contained herein or incorporated by reference.
- 1.3.1.27 Remedies; Attorneys Fees, and Costs: All remedies provided in this solicitation shall be deemed cumulative and additional, and not in lieu of or exclusive of each other or of any other remedy available at law or in equity arising hereunder. Should any legal proceedings at law or in equity arise under or in connection with this solicitation, the Contractor shall be responsible for all attorneys' fees and costs (including reasonable fees and charges for the services of paralegals or other personnel who operate for and under the supervision of such attorneys and whose

time is usually charged to clients) and any other expenses incurred in connection with such proceedings.

1.3.1.28 Department's Right to Audit: Books and Records: The Contractor shall, at all times during the term hereof, maintain complete and accurate books and records of its operations, including employee time records, in a form consistent with good accounting practice, including such books and records as would normally be examined by an independent certified public accountant in performing an audit or examination of the Contractor's receipts and expenses in accordance with generally accepted auditing standards. The Department has the right to designate an independent auditor to review books and records that specifically relate to this project. Subcontractors shall be bound by the same requirements. See: SECTION 6.9 - CONTROL OF THE CONTRACT of the GENERAL PROVISIONS in its entirety.

1.3.1.29 Confidential Material: All bids are subject to public inspection as set forth in 3-122-30, HAR. Bidders shall request in writing nondisclosure of designated trade secrets or other proprietary data to be confidential. Such data shall accompany the bid and shall be readily separable from the bid in order to facilitate eventual public inspection of the non-confidential portion of the bid. To facilitate the release of the information requested, the Department is prepared to sign a Non-Disclosure Agreement if necessary, however, the Department cannot guarantee that designated data will be kept confidential. The offers are subject to disclosure rules set forth in Chapter 92F, HRS and Non-Disclosure Agreements are enforceable only to the extent that they do not conflict with the provisions of Chapter 92F, HRS. The Bidder bears the burden of establishing that the designated data is exempted from the disclosure requirements set forth in Chapter 92F.

1.3.1.30 Cancellation of the Solicitation and Offer Rejection: The Department reserves the right to cancel this solicitation and to reject any and all offers in whole or in part, and waive any defects, when it is determined to be in the best interest of the Department, pursuant to HAR 3-122-96 and 3-122-97.

The Department shall not be liable for any costs, expense, loss of profit, or damages whatsoever, incurred by the Offeror in the event this solicitation is cancelled or an offer is rejected.

1.4 GENERAL PROVISIONS, SPECIFICATIONS, AND STANDARD DETAILS.

The Special Provisions, plans, General Provisions, Water Standards, County of Kaua'i Department of Public Works ("DPW") Standard Specifications and Details, as amended, contract documents, and all supplemental documents are essential parts of the contract, and a requirement occurring in one is as binding as though occurring in all. They are intended to be complementary and to describe and provide for the complete work. In case of conflict or discrepancy within any part of the contract, the stricter requirements,

including Hawai‘i State Statutory requirements, shall govern. Unless it is apparent that a different order of precedence is intended, the special provisions shall govern over plans, general provisions, and Water Standards; plans shall govern over general provisions; general provisions shall govern over Water Standards; Water Standards shall govern over DPW Standard Specifications; figured dimensions and drawings take precedence over measurements by scale, and detail drawings; instructions to proposers shall be incorporated and made a part of the special provisions.

It is the responsibility of the prospective offerors, offerors, and Contractors to review the General Provisions, Water Standards, Specifications, and Standard Details and a submission of an offer to this solicitation shall be deemed an acknowledgement of the incorporation of these into this solicitation and the resulting contract, if any.

- 1.4.1.1 General Provisions for Construction Contracts: The General Provisions for Construction Contracts of the Department of Water, dated April 25, 2016 (“General Provisions”) are included in this solicitation. A copy may be found in Appendix “B.”
- 1.4.1.2 Water System Standards. The “Water System Standards”, 2002, as amended, as adopted by the Department of Water, County of Kaua‘i; Board of Water Supply, City and County of Honolulu; Department of Water Supply, County of Maui; Department of Water Supply, County of Hawai‘i (“Water Standards”) is by reference incorporated herein and made a part of these specifications. The Water Standards specifications are not bound in these contract documents, but shall by reference be incorporated herein and made a part hereof.
- 1.4.1.3 Department of Public Works, County of Kaua‘i Standard Specifications: Whenever reference is made to the DPW Standard Specifications, the specifications referred to is the “HAWAI‘I STANDARD SPECIFICATIONS FOR ROAD, BRIDGE, AND PUBLIC WORKS CONSTRUCTION” of the State of Hawai‘i, 2005, as amended. These specifications are not bound in the Contract Documents, but shall by reference be incorporated herein and made a part hereof.
- 1.4.1.4 Department of Public Works, County of Kaua‘i, Standard Details: Whenever reference is made within these Special Provisions or the contract plans to the DPW Standard Details, the Details referred to is the “STANDARD DETAILS FOR PUBLIC WORKS CONSTRUCTION”, September 1984 and all subsequent amendments. These specifications are not bound in the Contract Documents, but shall by reference be incorporated herein and made a part hereof.

1.5 PROCUREMENT OFFICER AND CONTRACT ADMINISTRATOR.

The Procurement Officer is responsible for administrating/facilitating all requirements of the solicitation process and is the **sole point of contact for Offerors** from the date of release of the solicitation until the selection of the successful Bidder.

The Contract Administrator shall be responsible for the contract administration once the contract is awarded and shall be the point of contact throughout the term of the contract.

If checked, the Procurement Officer and the Contract Administrator shall be the same individual.

The Procurement Officer and Contract Administrator are:

Procurement Officer:

Val Reyna
Chief, Operations Division
Department of Water, County of Kauaʻi
4398 Pua Loke Street
Līhuʻe, HI 96766
Phone Number: 808-245-5434
Email: vreyna@kauaiwater.org

Contract Administrator:

Ryan Smith
Assistant Chief, Operations Division
Department of Water, County of Kauaʻi
4398 Pua Loke Street
Līhuʻe, HI 96766
Phone Number: 808-245-5436
Email: rsmith@kauaiwater.org

2 SCOPE OF WORK

2.1 SCOPE OF WORK.

This Contract consists of the following Scope of Work and includes all other necessary work, all as indicated in the contract drawings and specifications. The general location of the work is as shown on the contract plans and as described herein.

2.1.1.1

2.1.1.1 SCOPE:

- A. Furnish, assemble and provide start-up/testing of an on-site sodium hypochlorite generation (OSG) system of the type specified herein, in place complete, as shown on the drawings.
- B. This OSG system will be bid as a complete system.
- C. All components associated with the OSG unit, as specified herein, shall also be furnished by the OSG unit manufacturer or its regional representative. The OSG unit manufacturer or regional representative shall also furnish the sodium hypochlorite storage tank level transmitter as specified below.

2.1.1.2 RELATED WORK:

- A. The OSG unit manufacturer and/or its regional representative shall be responsible for the following:
 - i. OSG unit delivered to the site (Kauai, Makaleha Water Treatment Plant);
 - ii. Site assembly of the system including interconnecting piping between all major components (from the first micro-filter, water softener units, brine tank, OSG Unit, and to the Chlorine Storage Tank);
 - iii. Installation of the electrical conduit from OSG Unit Rectifier to the Water Treatment Plant's power source.
- B. The County of Kauai Department of Water shall be responsible for the following:
 - i. Preparation of the proposed location of the OSG Unit within the designated building;
 - ii. Make final water connections to the OSG system and from the OSG Chlorine Storage Tank to the Water Treatment Plant's Finish Water line;
 - iii. Install electrical wiring from OSG Unit Rectifier to the Water Treatment Plant's power source and make the required electrical wiring connections.

2.1.1.3 QUALIFICATIONS AND SUBMITTALS:

- A. Submit certification that the OSG unit manufacturer has at least ten (10) years of experience in the design and manufacture of Electrolytic Technology.
- B. Submit evidence that OSG unit of similar capacity and service capability has been in successful operation for at least three (3) years in a minimum of ten (10) separate installations.

- C. As safety is of critical importance, the Manufacturer must submit with the proposal details of any and all safety issues they have had with other sites with hydrogen over-pressurization or ignition. No response will be grounds for proposal disqualification.
- D. Submit certification that OSG unit has been pre-assembled and shop tested to assure compliance with pressure and operation requirements specified herein.
- E. Submit complete dimensioned shop drawings for OSG unit, including wiring diagram and electrical enclosure.
- F. Submit complete dimensioned shop drawings for all associated components, including softener, brine tank, sodium hypochlorite storage tank, dosing assembly and dilution panel, hydrogen dilution blower, acid cleaning system, low differential pressure switch, interconnecting pipe between the components, electrical conduit and hydrogen detector.
- G. Submit operation and maintenance manuals for OSG unit and all associated components, including spare parts list and warranty.

FACTORY REPRESENTATIVE: An authorized factory representative(s) shall review the assembly/installation of the OSG system and observe the operation of the system. Representative shall submit a written report stating that the system is correctly installed and is functioning in accordance with the requirements of this section. Representative shall provide a minimum of two (2) days on-site for this purpose, which shall include instructional and training time for Department of Water Supply personnel.

2.1.1.4 GENERAL: The OSG system shall be a complete Sodium Hypochlorite Generator system. Any proposed system must meet every operational and material aspect of this specification. Hydrogen management shall be accomplished by the passive venting of each electrolytic cell without potential restrictions such as baffle plates, orifice plates or backpressure valves. This flow path should not have baffle plates, orifice plates or backpressure valves between the last point of product generation and atmospheric evacuation. The electrolytic cells shall be designed to prevent an event whereby the generation of byproduct gas is or can be blocked such that an overpressure event that exceeds the capacity of the system to safely contain the pressure could exist. The presence of over-pressure rupture disks is not acceptable as the initiation of disk rupture would render the system inoperable. No hydrogen shall be vented directly to the hypochlorite storage tank where an accumulation could occur.

****Hydrogen management shall be accomplished by passive venting at each electrolytic cell. For operator safety, the cells shall be operated at atmospheric pressure, so that hydrogen gas cannot be contained or pressurized. No hydrogen shall be vented directly to the hypochlorite storage tank where an accumulation could occur. The OSG system shall be comprised of the following components:**

- A. Electrolytic Cell
 - i. The electrolytic cell shall be constructed of clear acrylic materials, allowing for full visual inspection of electrodes from all angles
 - ii. Cell construction shall be recirculating, vertical technology with cell electrodes and housing being a cartridge type designed for removal and installation as a single unit.
 - iii. Under no circumstance will internal fasteners, assemblies or baffles be part of the electrolytic cell construction. The only wetted parts of the cell construction will be the acrylic housing, free floating electrodes and viton o-ring seal. All cell fasteners shall be

titanium, exterior to the electrolytic process and never come into contact with the electrolyte.

- iv. The cells must operate at atmospheric pressure while purging hydrogen gas passively at the top of each cell so that hydrogen cannot be contained or pressurized
 - 1. NOTE 1: Under no circumstance will the above Hydrogen Safety Management requirements be relaxed or modified as it is a critical operator safety feature and core to the generator design.
 - 2. NOTE 2: The hydrogen safety design must be met, regardless of onsite generator manufacturer selected, and will be required for submittal approval.
 - 3. Under no circumstances will systems that incorporate rupture discs or orifice plates be allowed due to safety concerns.
- B. Type 316 stainless steel skid assembly
- C. Water Softener
- D. Brine Tank
- E. Filters for softened water and brine
- F. Skid-mounted OSG Unit, with major components being electrolytic cells, brine pump and appurtenances within cabinet below electrolytic cells, PLC control panel and D.C. rectifier. For safety reasons, under no circumstances shall water/liquids handling and/or electrolytic cells be located immediately above the power supply or rectifier.
- G. Sodium hypochlorite storage tank
- H. Hydrogen dilution blowers
- I. Acid cleaning system
- J. Low differential pressure switch
- K. Hydrogen detector

2.1.1.5 OSG UNIT:

Production Capacity:	8-10 lbs. per day (ppd) chlorine equivalent.
Control:	Automatic, regulated by storage tank level
Percentage sodium hypochlorite:	0.6% ± 0.05%
Consumables per pound of chlorine produced:	3.0-4.0 lbs. salt, 3.0-4.0 kWh (AC) 19-21 gallons of water
Water input:	Potable water, 50-80 psi, 55-78°F
Salt:	99.7% pure weight Morton White Crystal®, or equivalent
Power:	120/240 VAC, 1-phase, 60Hz
Control and D.C. Rectifier Cabinets:	Type 316 stainless steel NEMA 4X
Operator Interface:	6" color touch screen
Communication Interface:	Ethernet EN2TR
Programmable Logic Controller:	Modicon M221 PLC

2.1.1.6 WATER SOFTENER: Water softener shall be a, twin tank design, continuous operation, automatic regenerating water softener. A flow range of 11.5-18.0gpm, 35-gallon capacity and a



regeneration time of 45 min. Kinetico dual tank Model CC 206s, or approved equal shall be accepted.

2.1.1.7 BRINE TANK: Each tank is to be molded in one-piece seamless construction according to ASTM D 1998 and will be capable of storing the chemical application at atmospheric pressure. All polyethylene resin material shall contain a minimum of a U.V. 8 -15 stabilizer as compounded by the resin manufacturer. Pigments may be added at the purchaser's request but shall not exceed 0.25% (dry blended) of the total weight. Brine tank shall be a 56-gallon capacity, manual salt fill (560 Salt Capacity), 3/8-inch wall thickness high-density cross-linked polyethylene (HDLPE) calibrated tank.

2.1.1.8 CARTRIDGE FILTERS: Cartridge filters for softened water and brine shall have the following specifications:

- A. 10" Cartridge Housing
- B. Polypropylene Cap
- C. 300 Series SS Button Assembly
- D. Max temperature of 100°F
- E. Max Pressure 100 PSI (6.9 bar)
- F. The filter cartridge shall be a 50-micron, disposable cartridge.

2.1.1.9 SODIUM HYPOCHLORITE STORAGE TANK: Tank shall be a vertical tank shall be suitable for storage of 0.8% solution sodium hypochlorite.

- A. Material of construction shall be high-density cross-linked polyethylene (HDLPE).
- B. Pressure sensing-type electronic level transmitter which shall provide a 4-20 mA level signal for proper for operation of the generation equipment and alarm initiation.
- C. Minimum storage capacity shall be 550 gallons.
- D. The sodium hypochlorite storage tank shall be supplied with the following accessories utilizing threaded bulkhead fittings:
 - i. Vent connection.
 - ii. Fill connection.
 - iii. Forced air blower connection.
 - iv. Pump suction connection.
 - v. Drain and overflow connections.
 - vi. 18-inch threaded access manway with cover.

2.1.1.10 SODIUM HYPOCHLORITE METERING PUMP

- A. Under normal operating conditions, site generated sodium hypochlorite (nominally 0.8% ± 0.05%) will be injected into the process at locations shown on the drawings for disinfection.
- B. The metering pump shall be a diaphragm metering pump with a TEFC inverter-duty motor. Where multiple pumps are provided, all pumps shall be manufactured by a single manufacturer.
- C. The metering pump shall be suitable to operate 24-hours per day.

- D. The solution metering pump shall be able to operate with a 10:1 turn down ratio in conjunction with the VFDs.
- E. The following accessories for the sodium hypochlorite meter pump:
 - i. PVC calibration column.
 - ii. PVC chargeable pulsation dampener.
 - iii. PVC backpressure relief valve
 - iv. PVC pressure relief valve
 - v. Wye strainer
 - vi. Pressure gauge
- F. The OSHGS Supplier shall provide a VFD as part of the control package to control the metering pump. The VFD shall be provided with an epoxy-coated NEMA 4X enclosure and an easily-replaceable cooling fan. An elapsed timer is required to assist in preventative maintenance. The VFD shall have an LED five-digit display. VFD shall be V1000-4X by Yasakawa or approved equal.
- G. Metering pumps shall be Gamma/ X by ProMinent or approved equal.
- H. Chemical Dosing Assembly will be controlled by SCADA (by others).

2.1.1.11 HYDROGEN DILUTION BLOWER:

Blower with the following specification:

- A. Rating point: 10 ACFM @ 1.90 in. wg SP, 0.075./ft.³ Density
- B. Wheel: 10 x 9/16 radial wheel (full width)
- C. Inlet size: 4 inches
- D. Outlet size: 4 inches with ANSI-125 pound flange connection
- E. Motor: 80 watts, 115, 1- Phase, 60 Hertz, 2899 rpm

Manufactured by Fantech FR110 or approved equal.

2.1.1.12 ACID CLEANING SYSTEM: Acid cleaning system shall be a mobile system consisting of a 10-gallon bucket filled with cleaning acid through lid on the bucket top.

2.1.1.13 LOW DIFFERENTIAL PRESSURE SWITCH: Low differential pressure switch shall be rated for 15 @ 120-480 VAC, 60 Hz, single-pole double throw (SPDT) switch for general industrial service with operating range of 0.07 to 0.22 inch W.C. Supplier shall be Dwyer Model 1823-00, or approved equal.

2.1.1.14 HYDROGEN DETECTOR: A hydrogen gas monitoring system shall be provided to continuously measure and display gas concentration and provide alarms when preset limits are exceeded. A transmitter will send the signal to the control panel. The gas monitoring system shall have a NEMA 4X enclosure and two-line, eight-alphanumeric character LCD display with linear 4-20 mA output signal. Hydrogen detector shall be a Conspec Model CN06, or approved equal.

2.1.1.15 LEVEL TRANSMITTER FOR SODIUM HYPOCHLORITE STORAGE TANK: The OSHGS Supplier shall provide a pressure sensing-type electronic level transmitter which shall provide a 4-20 mA level signal for proper for operation of the generation equipment and alarm

initiation. Level controls for the tank shall be brought to the operator interface. Ultrasonic, Flowline LU83-5101, or approved equal.

2.1.1.16 INSTALLATION: Assemble/Install all components of the OSG system in accordance with the manufacturers' printed instructions, and as shown on the drawings.

2.1.1.17 TESTING: Demonstrate that all components of the OSG system operate properly within the full range of their capabilities. Any adjustments must be done by a certified representative of the manufacturer(s).

2.1.1.18 WARRANTY: Contractor shall warrant all components supplied to be free from defects in materials and workmanship for a period of three (3) years from the date of acceptance of the OSG system by the Owner.

2.1.1.19 SPARE PARTS PRICE LIST: Contractor shall include with their bid proposal a price list for the following replacement parts for the OSG unit:

- A. One (1) electrolytic cell cartridge
- B. One (1) metering pump
- C. One (1) brine pump
- D. One (1) differential pressure switch
- E. One (1) cell level switch
- F. One (1) cell temperature sensor
- G. One (1) solenoid valve

These prices are to be honored (remained unchanged) by the OSG unit manufacturer for a period of up to 24 months after the 3-year warranty has expired. All of the items on this price list must be deliverable to the project site by the manufacturer within 48 hours of being requested by the Owner.

2.2 TIME OF COMPLETION.

2.2.1.1 It is understood and agreed that the work called for under this Project must and shall be completed within **ONE HUNDRED EIGHTY (180) CALENDAR DAYS** after written notice has been given to the Contractor to commence work. No extension of time will be granted for shipping and manufacturer's delays. The Contractor shall be subject to liquidated damages for delay or nonperformance as stated in this solicitation.

2.2.1.2 Work on the basic contract agreement is to be completed within the stipulated completion time from the date to the "Notice to Proceed." All work shall be done in co-operation with and coordinated with any other Contractors in a manner to allow completion of the entire construction within the scheduled time.

2.3 PERMITS.

Not Applicable

2.4 CONTRACTOR'S RESPONSIBILITY FOR EXISTING UTILITIES AND STRUCTURES.

The existence and location of underground utilities and structures as shown on the plans are from the best information available but are not guaranteed and other obstacles may be encountered in the course of the work. Prior to the start of excavation, the Contractor shall contact all utility companies and have them locate their respective lines affected. The Contractor shall be held responsible for any damage to and for the maintenance and protection of existing utilities and structures. See: SECTION 6 - PERFORMANCE OF CONTRACT of the GENERAL PROVISIONS in its entirety.

2.5 POWER AND WATER SUPPLIES.

The Contractor shall make all the necessary arrangements and installation work that may be required for power and water supplies for the work under this Contract. Cost for said power and water supplies shall be included in appropriate unit prices bid and no direct payment will be made therefore.

2.6 CONTRACTORS LICENSE REQUIRED.

The Department shall reject all bids received from contractors who are not licensed by the State Contractors License Board in accordance with Chapter 444, Hawai'i Revised Statutes. It is the sole responsibility of the Bidder to review the requirements of this Project and determine the appropriate licenses that are required to complete the Project.

2.7 HOURS.

No work shall be done on Saturdays, Sundays, legal State Holidays and/or in excess of eight (8) hours each day without the written consent of the Contract Administrator. Should permission be granted to work at such times, the Contractor shall pay for all inspectional and administrative costs thereof. No work shall be done at night unless authorized by the Contract Administrator. No work shall be done at night during seabird fallout season (September 15 – December 15, annually). See: SECTION 6.9 and 6.12 of the GENERAL PROVISIONS.

2.8 QUANTITIES.

All bids will be compared on the basis of quantities of work to be done, as shown in the bid; the quantities shown in the Unit Price items are estimated, being given as a basis for comparison of bids. The Department reserves the right to increase or decrease the quantities or delete items entirely as may be required during the progress of the work. See: SECTION 7.2 and 7.3 of the GENERAL PROVISIONS.

2.9 MATERIALS FURNISHED FOR THE PROJECT.

All materials necessary for the completion of the project shall be furnished by the Contractor, unless specifically stated otherwise and full compensation thereof shall be included in the various items in the bid. All materials for this Project shall be ordered after the notice to proceed is issued and the shop drawings, if applicable, have been approved by the Department.

2.10 WORK TO BE DONE WITHOUT DIRECT PAYMENT.

Whenever it is specified in the contract that the Contractor is to do work or furnish materials of any kind for which no price is fixed in the contract, it shall be understood that such work or furnishing such materials was included in a unit price for the appropriate item, unless it is expressly specified that such work or material is to be paid for as extra work.

2.11 INTENT OF THE SPECIFICATIONS.

It is not the intent of the Department to limit Offerors to these specifications; however, the specifications designated as “requirements” contained herein are the minimum acceptable.

2.12 IMPLEMENTATION.

The Contractor will be required to:

2.12.1.1 Provide required permits for the construction of this Project, trained construction crew and project management necessary to ensure a complete constructed, and fully functional water facilities as specified in this solicitation.

2.12.1.2 Provide all documentation, including all warranties and certification documents, on the construction materials and/or equipment being used.

2.13 GOVERNING LAW; APPLICATION OF LAW.

This solicitation and the Contract awarded based on such solicitation shall be governed by the laws of the State of Hawai‘i. The Contractor shall comply with all federal, State and local laws, regulations and ordinances, including occupational safety and health standards applicable to the performance of the services specified.

3 METHOD OF AWARD

3.1 METHOD OF AWARD.

3.1.1.1 Award, if made, shall be to the responsive, responsible Offeror submitting the lowest Total Sum Bid price.

3.1.1.2 Only those offers that meet all of the solicitation specifications, General Provisions, Special Provisions, and any other requirement contained herein will be considered for award. Any offer that proposes terms, conditions, or requirements that are contrary to those specified herein or does not meet the qualification requirements of this solicitation, as solely determined by the Department and as provided herein, may be considered nonresponsive and will be rejected as provided herein.

3.2 HAWAI'I REVISED STATUTES.

The Contractor's attention is called to the following chapters within the HRS which affect this Contract and the performance thereof:

Chapter 103, relating to expenditure of public money;
Chapter 104, relating to wages and hours of employees on public works;
Chapter 376, relating to industrial safety;
Chapter 386, relating to workmen's compensation;
Chapter 321, relating to the Health Department;
Section 507-17, relating to recovery on bond for material and labor used on public works; and
Chapter 378, relating to fair employment practices

3.3 RESPONSIBILITY OF SUCCESSFUL BIDDER.

3.3.1.1 The successful Bidder is advised that it shall, immediately prior to award of the contract, furnish proof of compliance with the requirements of HAR §3-122-112, to wit: Chapter 237, tax clearance; Chapter 383, unemployment insurance; Chapter 386, workers' compensation; Chapter 392, temporary disability insurance; Chapter 393, prepaid health care; and one of the following: a) Be registered and incorporated or organized under the laws of the State (hereinafter referred to as a "Hawai'i business"); or b) Be registered to do business in the State (hereinafter referred to as a "compliant non-Hawai'i business."

3.3.1.2 To comply with these requirements, the successful Bidder shall produce the following documents to the Department to demonstrate compliance with this section.

HRS Chapter 237 Tax Clearance Requirement for Award and Final Payment. Instructions are as follows:

Pursuant to HRS §103D-328, successful Bidder shall be required to submit a tax clearance certificate issued by the Hawaii State Department of Taxation (“DOTAX”) and the U.S. Internal Revenue Service (“IRS”). The certificate is valid for six (6) months from the most recent approval stamp date on the certificate and must be valid on the date it is received by the Department of Water.

The tax clearance certificate shall be obtained on the State of Hawaii, DOT TAX CLEARANCE APPLICATION Form A-6 (Rev. 2003) which is available at the DOTAX and IRS offices in the State of Hawaii or the DOTAX website and by mail or fax:

DOTAX Website (forms & Information):

<http://www.state.hi.us/tax/alphalist.html#a>

DOTAX Forms by Fax/Mail: (808) 587-7572 / 1-800-222-7572

Completed tax clearance applications may be mailed, faxed or submitted in person to the Department of Taxation, Taxpayer Services Branch, to the address listed on the application.

DOTAX (fax): (808) 587-1488

IRS (fax): (808) 539-1573

The application for the clearance is the responsibility of the Bidder and must be submitted directly to the DOTAX or IRS and not to the Department of Water.

3.3.1.3 HRS Chapters 383 (Unemployment Insurance), 386 (Workers’ Compensation), 392 (Temporary Disability Insurance), and 393 (Prepaid Health Care) Requirements for Award. Instructions are as follows:

Pursuant to HRS §103D-310, the successful Bidder shall be required to submit an approved certificate of compliance issued by the Hawaii State Department of Labor and Industrial Relations (“DLIR”). The certificate is valid for six (6) months from the date of issue and must be valid on the date it is received by the Department.

The certificate of compliance shall be obtained on the State of Hawaii, DLIR APPLICATION FOR CERTIFICATE OF COMPLIANCE WITH SECTION 3-122-112, HAR, Form LIR#27 which is available at www.dlir.state.hi.us/LIR#27, or at the neighbor island DLIR District Offices. The DLIR will return the form to the Bidder who in turn shall submit it to the Department.



The application for the certificate is the responsibility of the Bidder and must be submitted directly to the DLIR and not to the Department of Water.

3.4 REQUIREMENT FOR AWARD.

To be eligible for award, the Bidder must comply as follows:

3.4.1.1 Hawaii Business. A business entity referred to as a “Hawaii business” is registered and incorporated or organized under the laws of the State of Hawaii. As evidence of compliance, Bidder shall submit a CERTIFICATE OF GOOD STANDING issued by the State of Hawaii Department of Commerce and Consumer Affairs Business Registration Division (“BREG”). A Hawaii business that is a sole proprietorship, however, is not required to register with the BREG and therefore not required to submit the certificate. A Bidder’s status as sole proprietor or other business entity and its business street address indicated on the OFFER form will be used to confirm that the Bidder is a Hawaii business.

3.4.1.2 Compliant Non-Hawaii Business. A business entity referred to as a “compliant non-Hawaii business” is not incorporated or organized under the laws of the State of Hawaii but is registered to do business in the State of Hawaii. As evidence of compliance, Bidder shall submit a CERTIFICATE OF GOOD STANDING.

To obtain a CERTIFICATE OF GOOD STANDING go online to www.BusinessRegistrations.com and follow the prompt instructions. To register or to obtain a “Certificate of Good Standing” by phone, call (808) 586-2727 (M-F 7:45 to 4:30 HST). The “Certificate of Good Standing” is valid for six months from date of issue and must be valid on the date it is received by the Department.

3.4.1.3 Registration Costs. Bidders are advised that there are costs associated with registering and obtaining a “Certificate of Good Standing” from the DCCA.

3.5 TIMELY SUBMISSION OF ALL CERTIFICATES.

3.5.1.1 The certificates described in this section should be applied for and submitted to the Department as soon as possible after the Department notifies the successful Bidder that the Department intends to issue an award to the successful Bidder. If valid certificates are not submitted within **ten (10) calendar days** after the Department so notifies the successful bidder, the successful Bidder’s offer may be disqualified and any prospective award (or actual award if mistakenly issued), even though the successful bidder’s bid is otherwise responsive and responsible, may be canceled without any liability whatsoever to the Department. The Department, and not the successful bidder, shall determine whether all necessary certificates have been timely submitted.

3.5.1.2 If the Department cancels any prospective or actual award for failure to submit all required certificates, the Department reserves the right to make an award to the next lowest responsive and responsible Bidder who is able to submit all the required certificates.

3.6 FINAL PAYMENT REQUIREMENTS.

Contractor is also required to submit a tax clearance certificate for final payment on the contract. A tax clearance certificate, not over two months old, with an original green certified copy stamp, must accompany the invoice for final payment on the contract. In addition to a tax clearance certificate, an original “Certification of Compliance for Final Payment” (SPO Form-22), will be required for final payment. This form is attached hereto as Appendix F.

4 AWARD OF CONTRACT AND NOTICE TO PROCEED

4.1 AWARD.

The successful Bidder shall comply with SECTION 3 - AWARD AND EXECUTION OF CONTRACT of the GENERAL PROVISIONS in its entirety.

4.2 NOTICE OF AWARD.

The Procurement Officer will inform the successful Bidder of contract award selection within 48 hours of confirmation. Additionally, an official contract award notification letter will be executed by the Department and provided at the earliest date.

4.3 NOTICE TO PROCEED.

Upon contract execution, a "Notice to Proceed" letter will be provided to the Contractor specifying the "Commencement" (start work) date of the Contract. No work is to be undertaken by the Contractor prior to the commencement date specified in the Notice to Proceed letter. The Department is not liable for any work, contract, costs, expenses, loss of profits, or any damages whatsoever incurred by the Contractor prior to the official Notice to Proceed "Commencement" date.

APPENDIX A: Sample Contract. (bound separately)



APPENDIX B: General Provisions for Construction Contracts for the Department of Water, dated April 25, 2016 (bound separately).



APPENDIX C: Offer.

Contractor _____

OFFER

For

DEPARTMENT OF WATER, COUNTY OF KAUA'I,
LĪHU'E, KAUA'I, HAWAI'I

_____ 20 _____

Manager and Chief Engineer
Department of Water
County of Kaua'i
4398 Pua Loke Street
Līhu'e, Hawai'i 96766

Dear Sir:

Pursuant to and in compliance with your Invitation For Bids and other Contract Documents relating thereto, the undersigned Offeror, having familiarized itself with the terms of the contract, the local conditions affecting the performance of the contract and the cost of the work at the place where the work is done, the plans and specifications, "General Provisions for Construction Contracts of the Department of Water", "Water System Standards, 2002", Invitation For Bids, and other Contract Documents, hereby proposes and agrees to perform, within the time stipulated in the said documents, including all its component parts and everything required to be performed, and to provide and furnish any and all of the labor, materials, tools, expendable equipment, and all utility and transportation services necessary to perform the contract, in a workmanlike manner, in place complete all of the work covered by the contract in connection with these specifications and accompanying construction plans titled:

JOB NO. 19-03 Makaleha On-Site Sodium Hypochlorite Generation Pilot Project, KAUA'I, HAWAI'I

on file in the office of the Department of Water for,

TOTAL SUM OFFER _____ DOLLARS
(words)

(\$ _____) said total sums being itemized on the following pages:



OFFER SCHEDULE

JOB NO. 19-3, KAUA'I, HAWAI'I

ITEM NO.	ESTIMATED QUANTITY	DESCRIPTION	UNIT PRICE	TOTAL
1	1 (LS)	On-Site Sodium Hypochlorite Generation System per provided specifications including installation. (OSG Unit includes water softener, brine tank, cartridge filters, acid cleaning system, and low differential pressure switch.)	\$ _____	\$ _____
2	1 (LS)	Startup and testing of new OSG.	\$ _____	\$ _____
3	16 (HR)	Training of DOW personnel (2 days).	\$ _____	\$ _____
4	1 (LS)	Spare parts per specifications.	\$ _____	\$ _____
5	1 (EA)	Sodium Hypochlorite Storage Tank per provided specifications.	\$ _____	\$ _____
6	1 (EA)	Storage Tank Level Transmitter per provided specifications.	\$ _____	\$ _____
7	2 (EA)	Sodium Hypochlorite Metering Pump per provided specifications.	\$ _____	\$ _____
8	1 (LS)	Hydrogen Dilution Blower and Hydrogen Detector per provided specifications.	\$ _____	\$ _____
		TOTAL SUM OFFER (Items 1 to 8 inclusive)		\$ _____

SCHEDULE B
HAWAI'I PRODUCTS PREFERENCE

In accordance with HRS §103D-1002, the Hawai'i products preference is applicable to this solicitation. Hawai'i Products ("HP") are available for those items noted on Schedule B, below. The Hawai'i products list is available on the SPO webpage at www.spo.hawaii.gov/for-state-county-personnel/manual/procurement/solicitation/goods-services-construction/preferences/hawaii-product-preferences/ or go to the SPO Home page, click on "For Vendors" tab; click on Preferences, Hawai'i Product Preferences to view. Offeror transmitting a Hawai'i Product (HP) shall identify the HP on Schedule B-1.

Any person desiring a Hawai'i product preference shall have the product(s) certified and qualified if not currently on the Hawai'i products list, prior to the deadline for receipt of offer(s) specified in the procurement notice and solicitation. The responsibility for certification and qualification shall rest upon the person requesting the preference. Persons desiring to qualify their product(s) not currently on the Hawai'i product list shall complete form SPO-038, Certification for Hawai'i Product Preference and submit, via email to the Procurement Officer issuing the solicitation, and provide the solicitation number and title in the subject line, and include all additional information required by the Procurement Officer. For each product, one form shall be completed and transmitted (i.e. 3 products should have 3 separate forms completed). Form SPO-038 is available on the SPO webpage at <http://hawaii.gov/spo> under the 'Quicklinks' menu; click on 'Forms for Vendors, Contractors, and Service Providers'.

When a solicitation contains both HP and non-HP, then for the purpose of selecting the lowest bid or purchase price only, the price offered for a HP item shall be decreased by subtracting 10% for the class I or 15% for the class II HP items offered, respectively. The lowest total offer, taking the preference into consideration, shall be awarded the contract unless the offer provides for additional award criteria. The contract amount of any contract awarded, however, shall be the amount of the price offered, exclusive of the preferences.

Change in Availability of Hawai'i product. In the event of any change that materially alters the Offeror's ability to supply Hawai'i products, the Offeror shall notify the Procurement Officer in writing no later than five (5) working days from when the Offeror knows of the change and the parties shall enter into discussions for the purposes of revising the contract or terminating the contract for convenience.

The following is a list of products that the Department anticipates will be used in this particular project; however the list is not all inclusive and additional products may be qualified.

HAWAI'I PRODUCTS LIST

HP Description	Manufacturer/Supplier	Class
----------------	-----------------------	-------



Bidders intending to use or supply a Hawai'i Product must list the price and total cost of each item f.o.b. jobsite, unloaded, including applicable general excise tax and use tax on this form. Failure to designate a Hawai'i product will mean that the Bidder is offering a non-Hawai'i product and award, if made to the bidder, will be on the basis that the bidder will deliver or use a non-Hawai'i product.

The Bidder shall list only the Manufacturers/Suppliers certified and qualified on Schedule B.

If the Department has awarded a contract under HRS, § 103D-1002, finds that in the performance of that contract there has been a failure to comply with HRS, § 103D-1002, the contract shall be voidable and the findings shall be referred for debarment or suspension proceedings under HRS 103D-702. Any purchase made or any contract awarded or executed in violation of this section shall be void and no payment shall be made by the Department on account of the purchase or contract.

SCHEDULE B-1
SCHEDULE OF MATERIAL COST
(if Hawai'i preference requested)

HAWAI'I PRODUCT	MANUFACTURER	CLASS	APPROX. QUANTITY	UNIT	TOTAL COST OF MATERIAL
Aggregates and Sand – Basalt, rock, cinder, limestone and coral					
Aggregates – Recycled asphalt and concrete					
Asphalt and paving materials					
Cement and concrete products					
Pre-cast concrete products					
Signs–traffic, regulatory and construction					
Soil amendments, mulch, compost					

SCHEDULE C
MANDATORY LICENSING REQUIREMENT

“A” general engineering contractors and “B” general building contractors are reminded that due to the Hawai‘i Supreme Court’s January 28, 2002 decision in Okada Trucking Co., Ltd. V. Board of Water Supply, et al., 97 Haw. 450 (2002), they are prohibited from undertaking any work, solely or as part of a larger project, that would require the general contractor to act as a specialty contractor in any area in which the general contractor has no license. Although the “A” and “B” contractor may still submit an offer on and act as the “prime” contractor on an “A” and “B” project (See, HRS § 444-7 for the definitions of an “A” and “B” project.), respectively, the “A” and “B” contractor may only perform work in the areas in which they have the appropriate “C” specialty contractor’s license (*An “A” or “B” contractor obtains “C” specialty contractor’s licenses either on its own, or automatically under HAR § 16-77-32.*). The remaining work must be subcontracted out to appropriately licensed “C” specialty contractors. It is the sole responsibility of the contractor to review the requirements of this project and determine the appropriate licenses that are required to complete the project.

LISTING OF SUBCONTRACTORS

Sec. 103D-302, H.R.S., provides that each offer for Public Works Construction Contracts shall include the name of each person or firm to be engaged by the Offeror as a joint contractor or subcontractor in the performance of the Public Works Construction Contract. The Offer shall also indicate the nature and scope of the work to be performed by such joint contractors or subcontractors. All offers which do not comply with this requirement shall be rejected pursuant to Sec. 103D-302(b) H.R.S.

To comply with the above provisions, the offeror shall complete the schedule of the nature and scope of work by listing, where applicable, the names of the joint contractors and subcontractors to be used after the description of the nature and scope of the work.

ALL JOINT CONTRACTORS OR SUBCONTRACTORS TO BE ENGAGED ON THIS PROJECT

The Offeror certifies that the following is a complete listing of all joint contractors and/or subcontractors who will be engaged by the Offeror on this Project to perform the nature and scope of work indicated **regardless of the percentage of the value of the work to be performed by the joint contractor or subcontractor**, pursuant to Section 103D-302, Hawai‘i Revised Statutes, and understands that failure to comply with this requirement shall be just cause for rejection of the Offer.

The Offeror further understands that only those joint contractors or subcontractors listed shall be allowed to perform work on this Project. If no joint contractor or subcontractor for any subdivision of work is listed, it shall be construed that the work shall be performed by the Offeror with Offeror’s employees.

All Offerors must be sure that they possess, and that the joint contractors or subcontractors listed in the Offer possess, all the necessary specialty licenses needed to perform the work for this Project. The Offeror shall be solely responsible for assuring that all specialty licenses required to perform the work is covered in the Offer.

The Offeror shall include the license number of the joint contractors or subcontractors listed below. Failure to provide the correct names and license numbers as registered with the Contractors Licensing Board may cause rejection of the offer submitted.

It is the sole responsibility of the contractor to review the requirements of this Project and determine the appropriate licenses that are required to complete the Project.

LISTING OF ALL JOINT CONTRACTORS OR SUBCONTRACTORS

Job No. 19-03

Makaleha On-Site Sodium Hypochlorite Generation Pilot Project



	Contractor Classification	Name of Joint Contractor or Subcontractor	License Number
C-1	Acoustical and Insulation Contractor		
C-2	Mechanical Insulation Contractor		
C-3	Asphalt Paving and Surfacing Contractor		
C-3a	Asphalt Concrete Patching, Sealing, and Striping Contractor		
C-3b	Play Court Surfacing Contractor		
C-4	Boiler, Hot-Water Heating and Steam Fitting Contractor		
C-5	Cabinet, Millwork, and Carpentry Remodeling and Repairs Contractor		
C-5a	Garage Door and Window Shutters Contractor		
C-5b	Siding Application Contractor		
C-6	Carpentry Framing Contractor		
C-7	Carpet Laying Contractor		
C-9	Cesspool Contractor		
C-10	Scaffolding Contractor		
C-12	Drywall Contractor		
C-13	Electrical Contractor		
C-14	Sign Contractor		
C-15	Electronic Systems Contractor		
C-15a	Fire and Burglar Alarm Contractor		
C-15b	Telecommunications Contractor		
C-16	Elevator Contractor		
C-16a	Conveyor Systems Contractor		
C-17	Excavating, Grading, and Trenching Contractor		
C-19	Asbestos Contractor		
C-20	Fire Protection Contractor		
C-20a	Fire Repressant Systems Contractor		

	Contractor Classification	Name of Joint Contractor or Subcontractor	License Number
C-21	Flooring Contractor		
C-22	Glazing and Tinting Contractor		
C-22a	Glass Tinting Contractor		
C-23	Gunite Contractor		
C-24	Building Moving and Wrecking Contractor		
C-25	Institutional and Commercial Equipment Contractor		
C-27	Landscaping Contractor		
C-27a	Hydro Mulching Contractor		
C-27b	Tree Trimming and Removal Contractor		
C-31	Masonry Contractor		
C-31a	Cement Concrete Contractor		
C-31b	Stone Masonry Contractor		
C-31c	Refractory Contractor		
C-31d	Tuckpointing and Caulking Contractor		
C-31e	Concrete Cutting, Drilling, Sawing, Coring, and Pressure Grouting Contractor		
C-32	Ornamental, Guardrail, and Fencing Contractor		
C-32a	Wood and Vinyl Fencing Contractor		
C-33	Painting and Decorating Contractor		
C-33a	Wall Coverings Contractor		
C-33b	Taping Contractor		
C-33c	Surface Treatment Contractor		
C-34	Soil Stabilization Contractor		
C-35	Pile Driving, Pile and Caisson Drilling, and Foundation Contractor		
C-36	Plastering Contractor		
C-36a	Lathing Contractor		

	Contractor Classification	Name of Joint Contractor or Subcontractor	License Number
C-37	Plumbing Contractor		
C-37a	Sewer and Drain Line Contractor		
C-37b	Irrigation and Lawn Sprinkler Systems Contractor		
C-37c	Vacuum and Air Systems Contractor		
C-37d	Water Chlorination and Sanitation Contractor		
C-37e	Treatment and Pumping Facilities Contractor		
C-37f	Fuel Dispensing Contractor		
C-38	Post Tensioning Contractor		
C-40	Refrigeration Contractor		
C-40a	Prefabricated Refrigerator Panels Contractor		
C-41	Reinforcing Steel Contractor		
C-42	Roofing Contractor		
C-42a	Aluminum and Other Metal Shingles Contractor		
C-42b	Wood Shingles and Wood Shakes Contractor		
C-42c	Concrete and Clay Tile Contractor		
C-42e	Urethane Foam Contractor		
C-42g	Roof coatings Contractor		
C-43	Sewer, Sewage Disposal, Drain, and Pipe Laying Contractor		
C-43a	Reconditioning and Repairing Pipeline Contractor		
C-44	Sheet Metal Contractor		
C-44a	Gutters Contractor		
C-44b	Awnings and Patio Cover Contractor		
C-48	Structural Steel Contractor		
C-48a	Steel Door Contractor		
C-49b	Hot Tub and Pool Contractor		

	Contractor Classification	Name of Joint Contractor or Subcontractor	License Number
C-51	Tile Contractor		
C-51a	Cultured Marble Contractor		
C-51b	Terrazzo Contractor		
C-52	Ventilating and Air Conditioning Contractor		
C-55	Waterproofing Contractor		
C-56	Welding Contractor		
C-57	Well Contractor		
C-57a	Pumps Installation Contractor		
C-57b	Injection Well Contractor		
C-60	Solar Power Systems Contractor		
C-61	Solar Energy Systems Contractor		
C-61a	Solar Hot Water Systems Contractor		
C-61b	Solar Heating and Cooling Systems Contractor		
C-62	Pole and Line Contractor		
C-62a	Pole Contractor		
C-63	High Voltage Electrical Contractor		
C-68	Classified Specialist		
	Licensed Surveyor		
	Licensed Geotechnical Engineer		
	Licensed Structural Engineer		
	Archaeologist		
	Cultural Monitor		
	Licensed Civil Engineer		
	Supervising Control and Data Acquisition (SCADA) Contractor		
*			
*			
*			
*			



	Contractor Classification	Name of Joint Contractor or Subcontractor	License Number
*			
*			

* Contractor to add licenses as required to complete the scope of work. Attach additional sheet as needed. It is understood and agreed that the Department reserves the right to reject any and/or all offers and waive any defects when, in the Department’s opinion, such rejection or waiver shall be for the best interest of the Department.

For purpose of evaluating the criterion described in this solicitation, it is understood and agreed that offers will be compared on the basis of the Total Sum Offer which shall be considered to be the total sum of actual or corrected amounts proposed on each item. The offerors signed Offer shall constitute the Offeror’s official offer. The Department reserves the right to designate the contract amount based on selected Offeror’s Total Sum Offer depending on the funds available for this Project.

It is also understood and agreed that the work called for under this Project must and shall be completed within **ONE HUNDRED EIGHTY (180)** consecutive calendar days after written notice has been given to the successful Offeror to commence work. It is also understood and agreed that the quantities given herewith are approximate only and are subject to increase or decrease and that the undersigned will perform all quantities of work, as either increase or decrease, in accordance with the provisions of the specifications.

It is also understood and agreed that the estimated quantities shown for items for which a UNIT PRICE is listed in the Offer are only for the purpose of comparing on a uniform basis offers offered for the work under this contract, and the undersigned agrees that the undersigned is satisfied with and will not dispute said estimated quantities as a means of comparing the offers. It is understood and agreed that the Offeror will make no claims for anticipated profit or loss of profit because of a difference between quantities of the various classes of work done or the materials and equipment actually installed and the said estimated quantities. On UNIT PRICE offers, payment will be made only for the actual number of units incorporated into the finished project at the contract UNIT PRICE.

It is also understood and agreed that if the product of the UNIT PRICE offer and the number of units does not equal the total amount stated by the Offeror in the offer for any item, it will be assumed that the error was made in computing the total amount. For purpose of evaluating the criterion described in this solicitation, the stated UNIT PRICE alone will be considered as representing the Offeror’s intention and the total amount offered on such item shall be considered to be the amount arrived at by multiplying the UNIT PRICE by the number of units.

It is also understood and agreed that the liquidated damages in the amount of **TWO HUNDRED FIFTY AND 00/100 DOLLARS (\$250.00)** for each and every calendar day in excess thereof prior to completion of the contract beyond the specified and approved completion date, shall be withheld from payments due to the Contractor, pursuant to the Damages for Delay provision contained in this solicitation.

It is also understood and agreed that if this offer is accepted, the successful offeror will contract with the Board and said offeror shall furnish the required bonds to the Board within ten (10) days from the date of receiving from the Board the contract prepared and ready for execution.



It is further understood and agreed that the successful offeror will provide all necessary materials, labor, tools, equipment, and other incidental necessary to do all the work and furnish all the materials specified in the contract in the manner and time herein prescribed and according to the requirements of the Department as therein set forth.

The undersigned further understands and agrees that by submitting this Offer, 1) the Offeror is declaring that the Offer is not in violation of Chapter 84, Hawai'i Revised Statutes, and 2) Offeror is certifying that the price(s) submitted was (were) independently arrived at without collusion.

It is also understood and agreed that if this Offer is accepted and the undersigned shall fail to or neglect to contract as aforesaid, the Board may determine that the offeror has abandoned the contract and thereupon forfeiture of the security accompanying the Offer shall operate and the same shall become the property of the Board.

- Enclosed herewith is a Bidder's Bond (Bid Security) for the sum
- Surety Bond
- Legal Tender
- Certificate of Deposit
- Share Certificate
- Cashier's Check
- Treasurer's Check
- Teller's Check
- Certified Check

of _____ DOLLARS
(\$ _____) payable to the Department of Water, being not less than the sum required under Sub-Section 2.9 "Bid Security" of the "General Provisions for Construction Contracts of the Department of Water", dated April 25, 2016.



Evidence of the undersigned Offeror having the authority to submit this Offer and to enter a contract is herewith furnished.

Respectfully submitted,

Name of Offeror

Authorized Signature

Print/Type Name & Title of above

Address, Zip Code

Telephone

Contractor's License No.

State of Hawai'i General Excise Tax License No.

Federal Employer Identification No.

Type of Organization: (Please designate)

- Sole Proprietorship Partnership
- Corporation Joint Venture
- Other (*please specify*) _____

State of Incorporation: Hawai'i Other (*please specify*) _____

Name of Performance Bond Surety Co. _____

Address _____

Authorized to do Business in the State of Hawai'i? Yes or No

If corporation, state who will sign contract and signatory's title:

Name

Title



Name	Title

If the Offeror is a **CORPORATION**, the legal name of the corporation shall be set forth on the Offer, together with the signature(s) of the Officer(s) authorized to sign on behalf of the corporation and the corporate seal affixed thereto. Evidence of the authority of the Officer(s) to sign on behalf of the Corporation **SHALL** be attached to this page and included in the Offer. Acceptable evidence of authority to sign includes, but is not limited to, a copy of the articles of incorporation, corporate resolution, or corporate by-laws. (See HRS Ch. 415, Hawai'i Business Corporation Act).

If the Offeror is a **LIMITED LIABILITY COMPANY**, the legal name of the company shall be set forth on the Offer, together with the signature(s) of the member of the limited liability company or manager of the manger-managed limited liability company authorized to sign on behalf of the entity. Evidence of the authority of the Officer(s) authorized to sign on behalf of the company **SHALL** be attached to this page and included in the Offer.

If the Offeror is a **PARTNERSHIP**, the legal name of the firm shall be set forth on the Offer, together with the signature(s) of the General Partner(s) authorized to sign on behalf of the partnership. Evidence of the authority of the General Partner(s) authorized to sign on behalf of the partnership **SHALL** be attached to this page and included with the Offer. Acceptable evidence of authority to sign for the partnership includes, but is not limited to, a copy of the partnership registration statement or authorization signed by all of the partners. (See HRS Ch. 425, Partnerships).

If Offeror is a SOLE PROPRIETORSHIP, Offeror's signature shall be placed above.

NOTE: PLEASE DO NOT DETACH THIS SAMPLE OFFER FROM THE SPECIFICATIONS. FILL IN ALL BLANK SPACES WITH INFORMATION REQUIRED OR OFFER MAY BE REJECTED.



APPENDIX D: Insurance. (bound separately)



APPENDIX E: Wage Certificate for Service Contracts

WAGE CERTIFICATE FOR CONSTRUCTION CONTRACTS

Projects subject to HRS 104

TO: Manager and Chief Engineer

SUBJECT: Solicitation No.: _____

PROJECT: _____

Pursuant to **HRS 103-55.5 Wages and Hours of Employees on Public Works Construction Contracts**, I hereby certify that if awarded the contract in excess of \$2,000, the work to be performed will be performed under the following conditions:

1. Individuals engaged in the performance of the contract on the job site shall be paid:
 - a. Not less than the wages that the director of labor and industrial relations shall have determined to be prevailing for corresponding classes of laborers and mechanics employed on public works projects; and
 - b. Overtime compensation at one and one-half times the basic hourly rate plus fringe benefits for hours worked on Saturday, Sunday, or a legal holiday of the State or in excess of eight hours on any other day; and
2. All applicable laws of the federal and state governments relating to workers' compensation, unemployment compensation, payment of wages, and safety shall be fully complied with.

Offeror: _____

By: _____

Title: _____

Date: _____



APPENDIX F: Certification of Compliance for Final Payment.

CERTIFICATION OF COMPLIANCE FOR FINAL PAYMENT
(Reference §3-122-112, HAR)

Reference: _____
(Contract Number) (IFB/RFP Number)

_____ affirms it is in
(Company Name)

compliance with all laws, as applicable, governing doing business in the State of Hawai‘i to include the following:

1. Chapter 383, HRS, Hawai‘i Employment Security Law – Unemployment Insurance;
2. Chapter 386, HRS, Worker’s Compensation Law;
3. Chapter 392, HRS, Temporary Disability Insurance;
4. Chapter 393, HRS, Prepaid Health Care Act; and

maintains a “Certificate of Good Standing” from the Department of Commerce and Consumer Affairs, Business Registration Division.

Moreover, _____
(Company Name)

acknowledges that making a false statement shall cause its suspension and may cause its debarment from future awards of contracts.

Signature: _____

Print Name: _____

Title: _____

Date: _____



APPENDIX G: Special Provisions.

TABLE OF CONTENTS FOR SPECIAL PROVISIONS

SECTION SP-1 – GENERAL REQUIREMENTS

<u>SECTION</u>	<u>DESCRIPTION</u>
<u>1.1</u>	<u>General Provisions, Specifications and Standard Details</u>
<u>1.2</u>	<u>Preconstruction Conference</u>
<u>1.3</u>	<u>Contractor’s Responses by Hardcopy or Electronic Mail</u>
<u>1.4</u>	<u>Failure to Complete On Time and Liquidated Damages</u>
<u>1.5</u>	<u>Measurements</u>
<u>1.6</u>	<u>Project Record Documents</u>
<u>1.7</u>	<u>Substitutions</u>
<u>1.8</u>	<u>Storage, Work Zone, Construction Access</u>
<u>1.9</u>	<u>Preservation of Property</u>
<u>1.10</u>	<u>Extra Work</u>
<u>1.11</u>	<u>Building Laws</u>
<u>1.12</u>	<u>Delivery of Materials at Site</u>
<u>1.13</u>	<u>Defective Materials</u>
<u>1.14</u>	<u>Clean-Up</u>
<u>1.15</u>	<u>Environmental Protection</u>
<u>1.16</u>	<u>Project Sign</u>
<u>1.17</u>	<u>Submittals</u>
<u>1.18</u>	<u>Contractor’s Operations</u>



SPECIAL PROVISIONS

SECTION SP-1 – GENERAL REQUIREMENTS

1.1 The following shall supplement the applicable subsections of Division 300 - Construction of the “Water System Standards”, 2002.

1.1.01

SECTION 302 WATER MAINS AND APPURTENANCES

The following shall supplement the applicable subsections of Division 300 - Construction of the “Water System Standards”, 2002.

Make the following amendments to said section:

SECTION 302.02 – TRENCH EXCAVATION.

Add the following paragraph to the “A. General” subsection:

Because construction will occur within residential neighborhoods, the Contractor shall secure all areas under construction with due regard for the safety of all persons and property at all times.

Amend the first paragraph of the “B. Payment” subsection to read:

Payment for trench excavation (without classification), backfill, select borrow, pipe cushion, and cost to safelysecure all areas under construction will not be paid for separately but shall be included in the Unit Price for the furnishing and installation of the various items in the Offer.

SECTION 302.03 – TRENCH BACKFILL.

Add the following paragraph to the “A. General” subsection:

If backfilling ground is continuously wet, pipe cushion and backfill material shall consist of coarse aggregate, ASTM C 33, Size Number 67, and shall be completely encapsulated with non-woven geotextile filter fabric unless approval for other material is granted.

Amend the first paragraph of the “G. Payment” subsection to read:

Payment for aggregate and sand pipe cushion surrounding the pipe, pipe bedding, non-woven geotextile filter fabric pipe cushion encasement, trench backfill, select borrow, warning tape, and backfill at valve boxes, meter boxes, manholes, and handholes will not be paid for separately but shall be included in the Unit Price for the furnishing and installation of the various items in the Offer.

SECTION 302.04 – SHEATHING.

Add the following paragraph to the “A. General” subsection:

Contractor shall provide and maintain sheathing and bracing as necessary to support excavation and trenching and shall comply with Occupational Safety & Health Administration (OSHA) requirements. The contractor shall deem a competent person for trench excavation and that person shall be on-site during all trench excavation and backfill.

Amend the entire “B. Payment” subsection to read:

Payment for installation and removal of sheathing and bracing, and for additional excavation (without classification), additional aggregate and sand cushion to surround the pipe, additional non-woven geotextile filter fabric to surround the cushion, additional bedding, and additional backfill required because of sheathing or bracing work will not be paid for separately but shall be included in the Unit Price for the furnishing and installation of the various items in the Offer.

SECTION 302.05 – DEWATERING.

Amend the first paragraph of the “A. General” subsection to read:

In locations where water is present in the trench, the Contractor must dewater by pumping or other means to keep the trench free of water during the installation of pipe cushion, the pipe itself, the testing, connection, relocation, lowering of the water mains, and until backfilling is completed to a point 12 inches above the top of the pipe. The Contractor shall provide proper facilities for delivering all pump water to its intended outfall location and attain all necessary permits required for discharge.

If the Contractor elects to discharge dewatering effluent into State Waters or existing drainage systems, the Contractor shall obtain NPDES General Permit Coverage authorizing discharges associated with construction activity dewatering from the Department of Health, Clean Water Branch (DOW-CWB). The Contractor shall prepare and submit permit application (CWB-NOI Form G) to DOH-CWB and shall not begin dewatering activities until DOH-CWB has issued Notice of General Permit Coverage (NGPC) and shall conduct dewatering operations in accordance with the conditions in NGPC. Contractor shall submit a copy of NPDES dewatering Application and Permit to the Manager.

Amend the entire “B. Payment” subsection to read:

Payment for dewatering activities, including but not limited to the preparation and implementation of NPDES General Permit Coverage authorizing discharges associated with construction activity dewatering, and the installation, maintenance, monitoring, and removal of Best Management Practices (BMPs), will not be paid for separately but shall be included in the Unit Price for the furnishing and installation of the various items in the Offer.

For all fines received by the Department for non-compliance with the Notice of General Permit Coverage (NGPC), the Contractor shall reimburse the Department within 30 days for the full amount of the outstanding cost the Department has incurred, or the Department will deduct the cost from the Contractor’s progress payment.

SECTION 302.06 – “ADOBE” OR CLAY.

Amend the entire “B. Payment” subsection to read:

Exclusive of the payments due for work defined in Section 302.07 – MUD REMOVAL AND CRUSHED ROCK TRENCH STABILIZATION, no separate payment for excavation (without classification) and removal of adobe, clay or other unsuitable material from the pipe trench or for necessary backfill material approved by the Manager to replace those materials will be made; the compensation for such work shall be deemed to be included in the Unit Price for the furnishing and installation of the various items in the Offer.

SECTION 302.07 – MUD REMOVAL AND CRUSHED ROCK TRENCH STABILIZATION.

Amend the first paragraph of the “B. Payment” subsection to read:

Payment for excavation (without classification) to remove and dispose of mud or undesirable materials from the pipe trench whether native or caused by contractor means and methods will not be paid for separately but shall be included in the Unit Price for the furnishing and installation of the various items in the Offer.

SECTION 302.08 – BLASTING.

Amend the entire “A. General” and “B. Payment” subsections to read:

No blasting shall be allowed on this project.

SECTION 302.09 – EXCAVATION FOR MANHOLES.

Amend the second paragraph of the “B. Payment” subsection to read:

Payment for excavation (without classification) for manholes will not be paid for separately but shall be deemed to be included in the Unit Price for the furnishing and installation of Manholes.

SECTION 302.10 - EXCAVATION FOR THRUST BLOCKS, BEAMS, AND TEST BLOCKS.

Amend the entire “B. Payment” subsection to read:

Payment for excavation (without classification) and backfill of concrete thrust blocks, thrust beams, reaction blocks, and test blocks will not be paid for separately but shall be included in the Unit Price for installation of Concrete Thrust Blocks, Thrust Beams, Reaction Blocks, and Test Blocks or Waterline installation line items.

SECTION 302.11 – SURPLUS EXCAVATION.

Amend the entire “B. Payment” subsection to read:

Payment for the removal and disposal of surplus excavation material will not be paid for separately but shall be included in the Unit Price for the furnishing and installation of the various items in the Offer.

SECTION 302.12 - DUCTILE IRON PIPE.

Add the following paragraph to the “A. General” subsection:

Transition couplings shall be Romac Style “501”, Style “RC501”, or approved equal. D.I. to A.C. transition couplings shall be 14" in length.

Add the following paragraphs to the “E. Payment” subsection:

The Unit Price for furnishing and installation of the various sizes of Ductile Iron Pipe shall be inclusive of trench excavation (without classification), trench backfill, pipe cushion, warning tape, sheathing and dewatering of trench, removal and disposal of adobe, clay, mud, and other unsuitable material from the trench, and removal and disposal of surplus excavation material, and all associated cost for licensed Geotechnical Engineer monitoring, analysis, and testing.

Payment for furnishing and installation of transition couplings shall not be made directly, costs for furnishing and installation of transition couplings shall be included in the Lump Sum for the various Connections to Existing Water Mains in the Offer.

SECTION 302.14 - PLASTIC PIPE.

Add the following paragraphs to the “A. General” subsection:

The contractor shall furnish and install Polyvinyl Chloride (PVC) pipe for this project if required. All types and sizes of PVC pipes shall be AWWA C900, Pressure Class 200, DR14 pipe for pipes larger than 2 ½” or schedule 80 PVC pipe for sizes 2 1/2” and smaller.

Pipe cushion material as called for on the plans shall adhere to the requirements of “Water System Standards” Section 209.02, Pipe Cushion. When ground water is encountered or when required by the Engineer, the pipe cushion shall be wrapped in non-woven geotextile fabric in accordance with the “Water System Standards” Section 212.05, Geotextile Fabrics. The contractor shall retain the services of a licensed Geotechnical Engineer to monitor the quality of pipe cushion material, installation, and compaction of the pipe cushion, geotextile encasement, and trench backfill. The Department of Water will require periodic sieve testing of the pipe cushion material during the course of construction.

If PVC installation will be within State Highways Right-of-Way, installation, work, and materials used for this project shall comply with the requirements in Section 624 – Water System, Section 703.21 – Trench Backfill Material, Section 716 – Geotextiles, and Section 716.03 – Geotextiles for Underdrain Applications of the “Specifications for Road and Bridge Construction”, State of Hawai‘i, dated 2005, unless otherwise approved by the authoritative agency.

Transition couplings shall be Romac Style "501", Style "RC501", or approved equal. C-900 PVC to A.C. transition couplings shall be 14" in length.

Amend the first paragraph of the "B. Payment" subsection to read:

Payment for furnishing and installation of various sizes of PVC Pipe including all necessary joints accessories and fusion process and accompanying ground restraints, will be made at the respective Unit Price per linear foot based on the actual linear feet of PVC pipe installed (exclusive of valves, fittings, bends, and adapters), cleaned or pigged and successfully hydrotested in the field.

Add the following paragraphs to the "B. Payment" subsection:

The Unit Price for furnishing and installation of the various sizes of PVC Pipe shall be inclusive of trench excavation (without classification), trench backfill, pipe cushion, geotextile filter fabric encasement, conducting cable, warning tape, sheathing, removal and disposal of adobe, clay, mud, and other unsuitable material from the trench, removal and disposal of surplus excavation material, and all associated cost for licensed Geotechnical Engineer monitoring, analysis, and testing.

Payment for furnishing and installation of transition couplings shall not be made directly, costs for furnishing and installation of transition couplings shall be included in the Lump Sum for the various Connections to Existing Water Mains in the Offer.

SECTION 302.15 - FITTINGS AND SPECIALS (DUCTILE IRON, CONCRETE CYLINDER, PLASTIC PVC PIPE).

Add the following paragraph to the "A.General" subsection:

The contractor shall furnish and install EBAA Iron Series 2000PV MEGALUG Mechanical Joint Restraint for plain end PVC pipe at all mechanical joint fittings and EBAA Iron Series 2100 MEGAFLANGE Restrained Flange Adapter for plain end PVC pipe at all flange joints. Both shall be installed in accordance with the manufacturer's guidelines.

Amend the first paragraph of the "B. Payment" subsection to read:

Payment for furnishing and installing Cast Iron and Ductile Iron Fittings will be made at the Lump Sum Price, complete in place. The Contractor shall be responsible for the actual number of cast iron and ductile iron fittings furnished, installed and tested in the field. If a line item for Cast Iron and Ductile Iron fittings is not specifically provided, the contractor shall include the cost in the furnishing and installation of the waterline unit price.

Amend the fourth paragraph of the "B. Payment" subsection to read:

Payment for furnishing and installation PVC Fittings, including copper toning wire will not be paid for separately but shall be included in the Unit Price for furnishing and installation of the various sized PVC Pipes in the Offer.

Amend the fifth paragraph of the “B. Payment” subsection to read:

Payment for furnishing and installation Flanged by Bell Adapters, Flanged Dismantling Joints, MEGALUG Mechanical Joint Restraint, and MEGAFLANGE Restrained Flange Adapters will not be paid for separately but shall be included in the Lump Sum Price for Cast Iron and Ductile Iron Fittings, in place complete.

SECTION 302.16- GATE VALVES AND BUTTERFLY VALVES.

Amend the first paragraph of the “A. General” subsection to read:

The contractor shall furnish and install all permanent and temporary gate valves and butterfly valves at locations shown on the plans or as directed by the Engineer. Unless otherwise specified, the installation shall be in accordance with the Standard Details. Specifications for furnishing and installing Temporary Gate Valves will comply with this section of the specification.

Amend the fourth paragraph of the “A. General” subsection to read:

Concrete anchor block with non-corrosive straps will not be required for this project.

Add the following paragraph to the “B. Payment” subsection:

The Unit Price for furnishing and installing Gate Valves and Butterfly Valves and furnishing and installing Temporary Gate Valves shall be inclusive of trench excavation (without classification), cast iron valve box, trench backfill, pipe cushion, warning tape, sheathing and dewatering of trench, removal and disposal of adobe, clay, mud, and other unsuitable material from the trench, and removal and disposal of surplus excavation material.

SECTION 302.17 - AIR RELIEF VALVES.

Add the following paragraph to the “A. General” subsection:

Air relief valves shall be One-Inch Val-Matic Valve & Manufacturing Corp. Combination Air Valve 201C.2 with screened hood, or approved equal.

Amend the second paragraph of the “B. Payment” subsection to read:

The Unit Price for furnishing and installation of Air Relief Valve shall be full compensation for all labor, materials, tools and equipment for excavation (without classification) and backfill, sheathing and dewatering of trench, installation of copper pipes, fittings, various types of valves, ARV, cinder or crush rock cushion, brick saddle, ARV pipe stand, concrete footing, roofing felt, stainless steel straps, screened hood, paint, testing, and all other incidentals to complete this work.

SECTION 302.18 - SERVICE LATERALS, CONNECTIONS AND PIPES.

Add the following paragraphs under “A. General” subsection:

New service laterals shall be terminated with an angle valve in the existing meter boxes to facilitate the reconnection to the water meter.

Where existing meters are located within private properties, the new service lateral will be terminated within the public right-of-way and include a new Type “B” or Type “X” meter box with cast iron cover.

When a new lateral is being installed for an existing Department of Water consumer, the contractor shall furnish and install lateral piping including all fittings and appurtenances between the new meter and the existing consumer piping and perform reconnection work, and include a new meter box and cover.

When an existing lateral is being abandoned, the contractor shall cut and plug the existing lateral at the main. The existing meter box and cover shall be cleaned and transported to the Department’s Baseyard in Līhu‘e or Pūhi, unless otherwise directed by the Engineer.

Amend the entire “D. Payment” subsection to read:

Payment covered under service laterals and connections and appurtenances shall be as follows: Payment for furnishing and installing various sizes of new service laterals and service connections, regardless of the lengths of the laterals or connections, will be made at the Unit Price per each unit based on the actual number installed and tested.

The Unit Price for furnishing and installing various sizes of new service laterals, service connections, and appurtenances shall be full compensation for all labor, materials, tools, and equipment for all handling, hauling, unloading, placing, testing, and all other incidental necessary to complete the work.

No separate payment for the furnishing and installation of taps into mains, reconnections to existing consumer piping, temporary connections, cut and plug and removal of existing laterals, transfer of meters, pipes, fittings, ball corps, ball stops, angle valves, globe valves, double hub fittings, tapping tees, service saddles, meter boxes and covers, meter splices, brass pipes, caps, PVC conduits, warning tape, polyethylene wrap, plastic lateral for isolation, nor any other appurtenances will be made. Additionally, no separate payment will be for trench excavation (without classification) and backfill, sheathing and dewatering of trench, pipe cushion, nor transporting existing meter boxes and covers to the Department’s Baseyard in Līhu‘e or Pūhi. The compensation for this work and items shall be deemed to be included in the Unit Price for New Service Laterals.

SECTION 302.19 – METER BOXES.

Amend the entire “B. Payment” subsection to read:

Payment for the furnishing and installation of meter boxes including frames and covers will not be paid for separately but shall be included in the Unit Price for Service Laterals or Air Relief Valve Assemblies.

Payment for the furnishing and installation of Meter Boxes shall be full compensation for all labor, materials, tools and equipment for all handling, hauling, unloading, placing,

bricks, concrete, cast iron covers, painting, concrete slabs and all other incidentals necessary to complete the work.

No separate payment for excavation (without classification) and backfill of Meter Boxes will be made; the compensation for such work shall be deemed to be included in the Unit Price for Service Laterals or Air Relief Valve Assemblies.

SECTION 302.20 - FIRE HYDRANTS.

Amend the third paragraph of the “B. Payment” subsection into the following paragraphs:

Payment for excavation (without classification), backfill, sheathing and dewatering of trench, and fire hydrant markers will not be paid for separately but shall be included in the Unit Price for the furnishing and installation of Fire Hydrants.

No separate payment for the furnishing and installation of hydrant elbow, hydrant extension, pipe cushion, flat brick support, and all other appurtenances will be made; the compensation for such work shall be deemed to be included in the Unit Price for Fire Hydrants.

SECTION 302.21 - FIRE HYDRANT MARKERS.

Amend the first paragraph of the “B. Payment” subsection to read:

Payment for hydrant markers will not be paid for separately but shall be included in the Unit Price for the furnishing and installation of Fire Hydrants.

SECTION 302.22 - CONCRETE BLOCKS, JACKETS, BEAMS, CURB GUARDS FOR FIRE HYDRANTS AND METER BOXES, MANHOLE AND VALVE BOX COLLAR.

Amend the entire “B. Payment” subsection to read:

Payment for concrete reaction blocks, thrust beams, thrust blocks and test blocks will be made at the Unit Price per each either by specific Offer line item or as a portion within the furnishing and installation of waterline line item. The Unit Price for concrete reaction blocks, thrust beams, thrust blocks and test blocks shall be full compensation for all labor, materials, tools and equipment for all excavation (without classification), backfill, sheathing, dewatering, concrete, forms, tie wire and chairs, bracings, straps, structural struts, surface finishing, curing, mixing, hauling, furnishing and placing reinforcing steel, and all other incidental materials and work necessary to construct the concrete reaction block, thrust block or thrust beam, in place complete.

Payment for concrete jackets will be made at the Unit Price per linear feet of concrete jacket installed for the various sizes of pipe, regardless of pipe size either by specific Offer line item or as a portion within the furnishing and installation of waterline line item. The Unit Price for concrete jackets shall be full compensation for all labor, materials, tools and equipment for all excavation (without classification), backfill, sheathing, dewatering, concrete, forms, tie wire and chairs, bracings, straps, surface

finishing, curing, mixing, hauling, furnishing and placing reinforcing steel, and all other incidental materials and work necessary to construct the concrete jackets in place complete.

Payment for concrete jackets for smaller utility conduits crossing the project's waterlines shall not be made separately. Costs for furnishing and installation of concrete jackets, including miscellaneous items such as warning tapes, shall be deemed to be included in the Unit Price for furnishing and installation of the various sizes and types of pipes in the Offer.

SECTION 302.24 - VALVE BOXES.

Amend the first paragraph of the "A. General" subsection to read:

Valve boxes for air relief valves, butterfly valves and cleanouts shall be installed in accordance with the Standard Details. Valve boxes for temporary and permanent gate valves shall be furnished and installed in conformance with Standard Detail V11 of the WATER SYSTEM STANDARDS or as defined on the construction drawing for this project. Valve boxes shall be installed 3 feet minimum clear from gutter, curbs, utilities and any structures. For this section, Valve Box specifications for Temporary and Permanent Gate Valves are identical.

Amend the entire "B Payment" subsection to read:

Payment for the furnishing and installing of valve boxes including cast iron frames and covers and adjusting valve boxes to the required grade will not be paid for separately but shall be included in the Unit Price for Gate Valves or Temporary Gate Valves or Tapping Valves or Cleanout assemblies.

Payment shall be full compensation for all labor, materials, tools and equipment for all excavation (without classification) and backfill, cast iron frames and covers, concrete settlement slab, reinforced concrete collar and leveling slab, standpipe (concrete, cast iron, ductile iron, or welded steel pipe), brick leveling course, crushed rock fill, pipe cushion, painting, general area clean up, and all other incidentals necessary to complete the work.

No separate payment for backfilling around valve boxes with black sand, sand or coral chips and for temporary backfill and additional excavation (without classification) to expose the risers after chlorination will be made; the compensation for such work shall be deemed to be included in the Unit Price for Gate Valves, Temporary Gate Valves, Tapping Valves, or Cleanout assemblies.

SECTION 302.30 – CONNECTIONS, RELOCATIONS & LOWERING OF WATER MAINS AND LATERALS.

Amend the first paragraph of the "A. General" subsection to read:

Whenever connections to, disconnections from, relocations to, or lowering of existing mains, service laterals, or hydrant laterals are required, the Contractor shall perform all work necessary for the installation of the new or temporary water facility or abandonment

of the existing water facility, as shown on the plans, under the coordination of the Manager or his authorized representative.

Add the following paragraph under “A. General” subsection:

The contractor shall utilize temporary waterlines to provide continuous water service and fire protection to existing consumers, as needed.

For this project, Connections to Existing Water Main involve connecting to various types of pipe. The Contractor shall not saw or cut or damage existing asbestos cement pipe. Asbestos cement pipes, fittings, and appurtenances shall be removed at the nearest coupling. The Contractor shall remove and dispose of asbestos cement pipes, fittings, and appurtenances in accordance with Section 302.31.

Amend the entire “B. Payment” subsection to read:

Payment for Connection to Existing Water Main, Connection to Existing Service Lateral, or Connection to Existing Hydrant Lateral which may include the furnishing and installing of pipes, fittings, fire hydrants, gate valves, tapping sleeves and valves, service saddles, hub clamps and other appurtenant materials, will be included in the Lump Sum Price for Connection to Existing Water Main or in the Unit Price for Connection to Existing Service Lateral, Connection to Existing Hydrant Lateral, or temporary bypasses and disconnects.

The Lump Sum Price or Unit Price shall represent full compensation for furnishing all materials, labor, tools, equipment, and incidentals required for excavation (without classification), backfill, sheathing and dewatering of trench, relocating existing gate valves, connections, relocations, disconnections, removal, or lowering of the existing mains as called for on the plans and in accordance with these specifications and inclusive of all incidentals required to complete the work.

No separate payment for cutting, plugging, relocating existing main, lowering of existing mains, providing temporary water service (if necessary), providing temporary fire protection (if necessary), or abandoning of existing mains will be made; the compensation for such work shall be deemed to be included in the Lump Sum for Connections to Existing Water Main or in the Unit Price for Connection to Existing Service Lateral or Connection to Existing Hydrant Lateral.

No separate payment for installation of bypass lines including cutting, plugging and abandoning existing bypass lines will be made; the compensation for such work shall be deemed to be included in the Lump Sum for Connections to Existing Water Main or in the Unit Price for Service Lateral Connections or Connection to Existing Hydrant Lateral.

SECTION 302.31 – REMOVING OR DEMOLISHING, REINSTALLING OR RETURNING EXISTING PIPES AND APPURTENANCES.

Add the following paragraphs under “A. General” subsection:

The contractor shall be responsible for removal and disposal of existing pipes and appurtenances abandoned within the State and County Right-of-Way. Removal and disposal of pipes shall follow all applicable OSHA, HIOSH, State of Hawai‘i and Federal Regulations. Abatement personnel shall oversee removal and disposal, when required. Unless otherwise directed by the Manager, pipes and appurtenances shall become the property of the Contractor and shall be expeditiously removed from the construction site.

Care shall be exercised when removing and disposing of asbestos cement pipe and appurtenances. If the contractor causes the asbestos cement pipe or appurtenance to become friable, he will not be reimbursed for extra costs incurred to handle, containerize, transport, and dispose of the waste. Disposal of asbestos cement pipe and appurtenances shall be at an approved asbestos disposal site and all disposal related costs shall be borne by the contractor. Disposal of all hazardous materials shall be completed within 24 hours of removal from the water system and shall not be stored within the project site beyond the 24 hour period.

Temporary pipes, fittings, valves, cleanouts, valve boxes with frames and covers, and appurtenances that were installed to provide temporary water service and fire protection shall be salvaged, cleaned, and transported to the Department’s Baseyard in Līhu‘e or Puhi.

Amend the first paragraph of the “B. Payment” subsection to read:

Payment for the removal, cleaning, and transporting of existing fire hydrants, standpipes, cleanouts, and air relief valves will be made at the Unit Price per each unit, based on the actual number removed and accepted by the Manager. If a specific Offer line item is not provided, the contractor shall incorporate the costs into the unit price of the furnishing and installation of the applicable waterline. The Unit Price includes full compensation for all labor, materials, tools, and equipment for removing, cleaning, plugging existing water mains, providing temporary water service, restoring disturbed area, and transporting salvaged fire hydrants, standpipes, air relief valves, and appurtenances to the Department’s Baseyard in Līhu‘e or Puhi.

Add the following paragraphs to the “B. Payment” subsection:

Payment for removal of existing gate and tapping valves will be made at the Unit Price per each unit, based on the actual number removed and accepted by the Manager. If a specific Offer line item is not provided, the contractor shall incorporate the costs into the unit price of the furnishing and installation of the applicable waterline. The Unit Price includes full compensation for all labor, materials, tools, and equipment for removing existing valve box components, removing concrete settlement slab, plugging of existing water mains, installing concrete and dirt backfilling, restoration of disturbed area, and cleaning and transporting the salvaged cast iron frames and covers to the Department’s Baseyard in Līhu‘e or Puhi.

Payment for removal of temporary gate valves and valve box components will be made at the Unit Price per each unit, based on the actual number removed and accepted by the Manager. If a specific Offer line item is not provided, the contractor shall incorporate the costs into the unit price of the furnishing and installation of the applicable waterline. The Unit Price includes full compensation for all labor, materials, tools, and equipment

for removing the temporary gate valves and valve box components, removing concrete settlement slab, installing concrete and dirt backfill, restoration of disturbed area, and cleaning and transporting salvaged gate valves and cast iron frames and covers to the Department's Baseyard in Līhu'e or Puhi.

Payment for the removal of temporary pipes and fittings will be made at the Lump Sum or Unit Price for Removal Temporary Water Main. The Lump Sum or Unit Price includes full compensation for all labor, materials, tools, and equipment for excavating (without classification), sheathing, dewatering, disconnecting and removing the temporary pipe and fittings, backfill and restoration of disturbed area, and cleaning and transporting salvaged pipes and fittings to the Department's Baseyard in Līhu'e or Puhi.

Payment for the removal and disposal of existing pipes, fittings, and appurtenances within the State and County Right-of-Way will be made at the Lump Sum or Unit Price for Removal of Water Main. The Lump Sum or Unit Price shall be full compensation for all labor, materials, tools and equipment for excavating (without classification), sheathing, dewatering, disconnecting, removing, processing, storing, hauling, and disposing of abandoned pipes and fittings, backfill and restoration of disturbed area, abatement personnel, disposal and inspection fees, cutting and plugging of existing water mains and laterals, and all other incidental materials and work necessary for the complete removal of abandoned pipes, fittings, and appurtenances.

Payment for the removal and disposal of existing pipes and appurtenances not specified above shall be considered incidental and shall not be paid for separately but shall be included in the Unit Price or Lump Sum for the various items in the Offer. Payment shall be full compensation for all labor, materials, tools and equipment for excavating (without classification), sheathing, dewatering, disconnecting, removing, hauling, storing, and disposing of abandoned pipes and fittings, backfilling and restoring disturbed area, disposal and inspection fees, cutting and plugging of existing water mains and laterals, and all other incidental materials and work necessary for the complete removal of abandoned pipes and appurtenances.

SECTION 302.35 - VALVE MARKERS.

Amend the entire "B Payment" subsection to read:

Payment for the furnishing and installation of Valve Markers will not be paid for separately, but shall be included in the Unit Price for the installation of various sized of gate or tapping valves. Payment shall be full compensation for all labor, materials, tools and equipment for all excavation (without classification), backfill, concrete, painting, and all other incidental materials and work necessary to complete the work.

SECTION 302.36 – SLOW CURING ASPHALT PAVEMENT (COLD MIX).

Amend "B. Payment", replace the first paragraph with the following:

Payment for furnishing, placement, maintenance and removal of SLOW CURING ASPHALT (Cold Mix) shall be deemed to be included in the Unit Price for furnishing and installation of the various sizes and types of pipes in the Offer.

SECTION 302.37 - RESTORING PAVEMENTS, DRIVEWAYS, SIDEWALKS, CURBS, GUTTERS, FENCES, WALLS, AND MISCELLANEOUS.

Add the following paragraphs under “A. General” subsection:

Asphalt concrete (A.C.) pavement resurfacing work shall include cold planing a 2-inch thick layer of existing A.C. pavement and resurfacing with a minimum 2-inch thick layer of new A.C. pavement (State Mix IV or V). Cold planing and resurfacing of A.C. pavement shall be in accordance with the Hawai‘i Standard Specifications for Road and Bridge Construction, 2005. The contractor shall construct the project per the approved construction drawings details and notes and verify potential AC thicknesses that could be encountered prior to submitting a Offer.

Existing pavement striping disturbed by this project shall be restored using thermoplastic extrusion. Painting is not acceptable. Installation of thermoplastic extrusion shall be in accordance with the Hawai‘i Standard Specifications for Road and Bridge Construction, 2005.

Existing reinforced concrete sidewalks, curbs, gutters, ramps, driveways, and swales disturbed by this project shall be restored to State Highways Standards in accordance with the Hawai‘i Standard Specifications for Road and Bridge Construction, 2005 and the Highway’s Division, Design Branch, Standard Plans, 2008.

Amend the entire “C. Payment” subsection to read:

Unless otherwise specified, payment for restoring fences, mail boxes, walls, landscaping, highway signs, highway markers and reflectors, and thermoplastic pavement striping shall not be measured nor paid for directly but shall be considered incidental to the construction work.

Payment for Restoring A.C. Pavement, inclusive of base and subbase courses, will be made at the Unit Price per square yard based on the minimum quantity required to be replaced on the approved plans, measured on the basis of the area of trenches specified for excavation plus an additional of twelve inches on each side of the trench for restoration within the State Right-of-Way or six inches on each side of the trench for restoration within the County Right-of-Way. The Unit Price shall be full compensation for all labor materials, tools, and equipment, for all handling, removing, placing, maintaining and all other incidental materials and work necessary to complete the Restoring A.C. Pavement work.

Payment for Cold Planing Existing A.C. Pavement and A.C. Pavement Resurfacing will each be made at the Unit Price per square yard based on the minimum quantities required as noted on the approved plans. Each Unit Price shall be full compensation for all labor materials, tools, and equipment, for all handling, removing, placing, maintaining and all other incidental materials and work necessary to complete the Cold Planing of Existing A.C. Pavement and A.C. Pavement Resurfacing work.

Payment for A.C. Pavement resurfacing, will be made at the Unit Price per square yard based on the minimum quantity required to be replaced on the approved plans, measured on the basis of the area of roadway required to be resurfaced within the State Right-of-

Way or County Right-of-Way. The Unit Price shall be full compensation for all labor materials, tools, and equipment, for all handling, removing, placing, maintaining and all other incidental materials and work necessary to complete the A.C. Pavement resurfacing work.

Unless otherwise specified, payment for restoration of Reinforced Concrete Sidewalk, Curbs, and Ramps, Reinforced Concrete Driveway, AC Driveways and Reinforced Concrete Swale shall not be measured nor paid for directly but shall be considered incidental to the construction work. If specified as a Unit Price, the Unit Price shall be full compensation for all labor materials, tools, and equipment, for all handling, removing, placing, finishing, maintaining, installation of forms, steel or weld wire fabric reinforcement, base course, and all other incidental materials and work necessary to complete the restoration of Reinforced Concrete Sidewalk, Curbs, and Ramps, Reinforced Concrete Driveway, AC Driveway and Reinforced Concrete Swale work.

Add the Following Section:

SECTION 302.40 - BRACING OF UTILITY POLES.

When excavating close to utility poles, when specified on the plans, or when directed by the Manager, the Contractor shall brace the utility pole if the utility pole is owned by Hawaiian Telcom or pay for bracing if the utility pole is owned by Kaua'i Island Utility Cooperative (KIUC). In addition to "Bracing of Utility Poles", the utility agency(s) may require the contractor to stabilize the ground adjacent to the pole(s). "Bracing of Utility Poles" and stabilizing the ground adjacent to the utility pole(s) includes all labor, materials, tools, and equipment necessary to install braces for existing utility poles, stabilize the ground adjacent to the utility poles, and for their removal when bracing and/or stabilizing are no longer necessary. Payment for bracing of utility poles or reimbursement for utility poles braced by KIUC or stabilizing the ground adjacent to the utility poles will not be made directly but shall be included in the Unit Price for the various items in the Offer.

Add the Following Section:

SECTION 302.41 – TRAFFIC CONTROL

Unless provided a specific line item in the Offer, Payment for traffic control work will not be made directly but shall be included in the Unit Price for the various items in the Offer.

SECTION 302.42 - REMOVING AND SALVAGING/DISPOSING OF MATERIALS.

Payment for removal and salvage or disposal of materials (fire hydrants, standpipes, valve boxes, etc.) and for the restoration of the area shall not be made directly; costs for these items of work shall be included in the unit price offer for the various items in the Offer.

Add the Following Section:

SECTION 302.43 – EROSION CONTROL / BMP

Payment for all erosion control / BMP measures shown on the drawings will not be made directly but shall be included in the Unit Price for waterline installation.

- 1.2 PRECONSTRUCTION CONFERENCE: The Contractor shall arrange a preconstruction conference with the Project Manager, along with other affected agencies, firms and individuals within seven (7) days after issuance of “Notice to Proceed”.

The Contractor shall submit a construction schedule to the Department of Water at the conference. This construction schedule shall be closely adhered to throughout the period of the contract.

At the preconstruction conference, the Contractor shall submit to the Department, the name of its authorized superintendent of the job.

The Contractor shall notify the Department at least three (3) working days prior to the start of construction.

- 1.3 CONTRACTOR’S RESPONSES BY HARDCOPY OR ELECTRONIC MAIL: The Contractor may respond in writing by submitting a hardcopy or by electronic mail only to the following Department’s requests:

- A. Notice of Intention to Propose.
- B. Request for Clarification.
- C. Pre-Offer Due Date Modification or Withdrawal of Offers.

The hardcopy shall be submitted as specified in the applicable subsection and shall include the following information:

To : Manager & Chief Engineer
Department of Water, County of Kaua‘i

Attention : Val Reyna

From :

Date :

Subject : (Subject)

**JOB NO. 19-03 Makaleha On-Site Sodium Hypochlorite Generation
Pilot Project KAUA‘I, HAWAI‘I**



- 1.4 FAILURE TO COMPLETE ON TIME AND LIQUIDATED DAMAGES: The Contractor shall complete the work within the number of calendar days specified in the contract. The specified number of calendar days shall commence from the date designated in the Notice to Proceed.

Completion of the work within the required time is important since delay in the prosecution of the work will inconvenience the public, obstruct traffic and interfere with business.

The Contractor understands and agrees that time is an essential factor of this Contract, and that the Department will suffer material loss by reason of delays that may occur in the Contractor's performance of the work or any portions of the work within the time or times fixed in this Contract or any extensions thereto. When the Contractor is given notice of delay or nonperformance, as specified in the Termination for Default clause of this Contract, and fails to cure in the time specified, the Contractor shall pay to the Department, as liquidated damages for any such delays, **TWO HUNDRED FIFTY AND 00/100 DOLLARS (\$250.00)** for each and every calendar day of delay or nonperformance from the day set for cure until either the Department reasonably obtains similar Goods or Services if the Contractor is terminated for default, or until the Contractor provides the Goods or Services if the Contractor is not terminated for default. The sums of each and every calendar day of delay or nonperformance shall be deducted from the Contract price. It is expressly stipulated by and between the Contractor and the Department that any such sums shall be deemed and taken to be liquidated damages for the Contractor's failure to perform within the specified time or times and not be in the nature of a penalty. To the extent that the Contractor's delay or nonperformance is excused under the Termination for Default clause of this Contract, liquidated damages shall not be due the Department. The Contractor remains liable for all unexcused nonperformance or delay.

- 1.5 MEASUREMENTS: Figured dimensions and drawings take precedence over measurements by scale. The Contractor must verify all measurements at the site and be responsible for the accuracy of the same.

1.6 PROJECT RECORD DOCUMENTS:

- 1.6.01 SECTION INCLUDES: Overview of maintenance of documents, recording requirements, and submittal of Project Record Documents.

1.6.02 MAINTENANCE OF DOCUMENTS:

A. Maintain a record copy of the following Project Record Documents on-site and record actual revisions to the work:

- (1) Contract Drawings.
- (2) Specifications.
- (3) Amendments.
- (4) Change orders and other modifications to the Contract.
- (5) Reviewed submittals.
- (6) Permits. (Road, Building, Noise, NPDES, etc.)
- (7) Specified installer/tradesman certificates.
- (8) Update Revisions to BMP plans as required by NPDES permit(s).
- (9) Other Project Record Documents as indicated in specific Specification sections.

- B. Store Project Record Documents apart from other documents. Provide separate files, racks, and secure storage for Project Record Documents.
- C. Record information concurrent with construction progress.
- D. Label and file Project Record Documents in accordance with these Specifications. Label each document “PROJECT RECORD” in neat, large, printed letters.
- E. Maintain Project Record Documents in a clean, dry and legible condition.
- F. Keep Project Record Documents available for inspection.

1.6.03 RECORDING REQUIREMENTS:

- A. Use an erasable red pencil (not ink or indelible pencil) to clearly record information or changes on the Drawings by graphic line and note as required. Use an erasable yellow pencil to clearly mark for verification all major components shown as constructed.
- B. Use different colors for overlapping changes if required for clarification.
- C. Record information concurrently with construction progress. Do not conceal any work until required information is recorded. Date all entries reflecting change.
- D. Legibly mark each item on the Drawings to record actual construction, including:
 - (1) Measured horizontal and vertical locations of underground utilities and appurtenances, referenced to permanent surface improvements.
 - (2) Field changes of dimension and detail.
 - (3) Changes made by Contract amendments and modifications.
 - (4) Details not on original Drawings.
 - (5) References to related shop drawings.
- E. Specifications: Legibly mark each item to record actual construction, including the following:
 - (1) Manufacturer’s name and product model and number.
 - (2) Product substitutions or alternates utilized, as approved by DOW.
 - (3) Changes made by amendment and contract modifications.
- F. As-Built Drawings: The contractor shall provide and keep up-to-date a complete set of as-built prints for this project which shall be corrected regularly, showing every change from the original contract drawing set, including all addenda, change orders

job decisions, etc. The as-built prints shall be used only as a record set and shall be kept on the job site available for the Department's review.

At the time of the final inspection, the contractor shall furnish the Department with one hard copy set of the as built drawings for review. After DOW provides review comments to the contract, the contractor shall provide one hard copy Mylar set with all original signatures and redline changes (**also CADD format and PDF format on CD**) showing all of the changes from the original contract set drawings including addenda, change orders, job decisions, etc. The "As-built Drawings" will be required to include the information stated in the General Provisions and prior to final acceptance as stated in the General Provisions. The "RECORD TRACINGS" block shall be utilized and signature blocks for the contractor, engineer and DOW Manager shall be provided on all sheets.

1.6.04 SUBMITTALS:

- A. At the completion of construction, deliver Project Record Documents.
- B. Transmit the Project Record Documents with a cover letter listing.
 - (1) Date.
 - (2) Project title and number.
 - (3) Contractor's name, address, and telephone number.
 - (4) Number and title of each Project Record Document.
 - (5) Signature of Contractor or authorized representative.

1.7 SUBSTITUTIONS

- A. The materials or products specified herein by trade name shall be provided as specified. Notwithstanding any reference in the specifications to any article, device, product, material, fixture, form or type of construction by name, make or catalog number, such references shall be interpreted as establishing a standard of quality and shall not be construed as limiting competition. Brand names where used on the plans or in the specifications shall be presumed to be followed by the words "or approved equal." Such approval will be granted only under the following conditions: Substitution of a brand other than specifically name in the contract documents will be approved by the Department of Water if it meets the following conditions:
 - 1. That it is equal or superior to the brand name in the specifications in construction, efficiency and utility.
 - 2. That it is equal or less in cost to the Owner.
 - 3. That during the construction period, the material or product specified cannot be delivered to the job in time to complete the work in proper sequence due to conditions beyond the control of the Contractor.
- B. To receive consideration, request for substitutions must be accompanied by documentary proof of the quality, difference in price and delivery, if any, in the form of certified quotations from suppliers of, both, specified and proposed materials or products. In case

of a difference in price, the County shall receive all-benefit of the difference in cost involved by change order or credit the County with any savings so obtained.

- C. If substitution of any brand other than the one specifically named requires changes to work detailed or specified under other headings, then the Contractor assumes all responsibility for this work.
- D. Substitution request must be received by said date in Section 1.9 “Substitute Materials” (Section 1-Administration, Page 20).

1.8 STORAGE, WORK ZONE, AND CONSTRUCTION ACCESS: Department of Water shall not assume the responsibility to approve proposed storage areas, work zones, and construction traffic pattern in and out of the project site. The Contractor shall be responsible for all additional NPDES permits, as well as, all updates to approved BMPs per NPDES permit approval requirements.

1.9 PRESERVATION OF PROPERTY: Due care shall be exercised to avoid injury to existing roadway improvements or facilities, utility facilities, adjacent property and roadside trees, shrubs and other plants that are not to be removed.

Roadside trees, shrubs and other plants that are not to be removed, and pole lines, fences, walls, signs, markers and monuments, buildings and structures, manholes and handholes, conduits, pipelines under or above ground, drain and sewer and water lines, all roadway facilities and any other improvements or facilities within or adjacent to the project shall be protected from injury or damage and if ordered by the Department of Water, the Contractor shall provide and install suitable safeguards, approved by the Department of Water, to protect such objects from injury or damage. If such objects are injured or damaged by reason of the Contractor’s operations, they shall be replaced or restored at the Contractor’s expense. The facilities shall be replaced or restored to a condition as good as when the Contractor entered upon the work, or as good as required by specifications accompanying the contract. The Department of Water may require the Contractor to make or cause to be made such temporary repairs borne by the Contractor and may be deducted from any moneys due or to become due to the Contractor under this contract. The fact that any underground facility is not shown upon the plans shall not relieve the Contractor of his or her responsibility. It shall be the Contractor’s responsibility to ascertain the existence of any underground improvements or facilities which may be subject to damage by reason of this operation.

Full compensation for furnishing all labor, materials, tools, equipment and incidentals, and for doing all the work involved in protecting or repairing property shall be considered as included in the prices paid for the various contract items of work and no additional compensation will be allowed.

1.10 EXTRA WORK: No work of any kind in connection with the work covered by these specifications and plans shall be considered as extra work, or entitles the Contractor to extra compensation, except when the work has been ordered in writing by the Department of Water prior to the performance of such work, and specifically referred to as EXTRA WORK and the amount of compensation stated in the change order.

1.11 BUILDING LAWS: The Contractor shall comply with the local laws, ordinances, rules, and regulations bearing on the work and he must obtain and pay for all permits, licenses, certificates



and give all notices required thereby.

- 1.12 DELIVERY OF MATERIALS AT SITE: Have all materials delivered at the site in such quantities as will ensure the uninterrupted progress of the work and the least obstruction of the premises and the adjoining property.
- 1.13 DEFECTIVE MATERIALS: When requested, furnish, without charge, samples of all materials entering into the work. All materials not conforming to the requirements of these specifications shall be considered as defective and all such materials, whether in place or not, shall be rejected.
- 1.14 CLEAN UP: On the completion of each day's work during this construction project, the Contractor shall remove from the site all debris, tools and excess material resulting from the Contractor or the subcontractor's work and leave the work and any affected surrounding areas broom clean.
- 1.15 ENVIRONMENTAL PROTECTION: The Contractor shall comply with the requirements for pollution control in performing all construction activities as set forth in the General Provisions.
- 1.16 PROJECT SIGN: **NOT APPLICABLE**
- 1.17 SUBMITTALS:

- 1.17.01 SECTION INCLUDES: Overview of transmittal of submittals, submittals requirements, definition of submittal for review and definition of submittal for closeout.

- 1.17.02 RELATED SECTIONS: Section 1.6 Project Record Documents.

- 1.17.03 TRANSMITTAL OF SUBMITTALS:

- A. General: Transmit submittals, number of copies as indicated in subsequent articles, to the following address:

- Kaua'i Department of Water
Attn: Val Reyna
4398 Pua Loke Street
Līhu'e, Kaua'i, Hawai'i 96766

- B. Submittals for Review: Transmit one (1) copy to the Department of Water for review. The Department will retain electronic set and return the one (1) reviewed set. Where the contractor requires more sets returned, contractor shall provide the additional sets at its own cost. Where more copies are called for in any section of these Special Provisions, the Contractor shall be required to submit said number of prints for approval.

- Whenever possible, submittals/transmittals shall also be submitted electronically.

- C. Submittals for Closeout:

- (1) Operations and Maintenance Manuals:

- a. Preliminary Submittal: Transmit two (2) copies of manual to the Department of Water two (2) weeks prior to final inspection. These copies will be returned after final inspection, with comments.
 - b. Final Submittal: Revise manuals and submit three (3) copies to the Department of Water two (2) weeks after receipt of comments to Preliminary Submittal.
- (2) Project Record Documents: Submit Project Record Documents at the time of final inspection.

1.17.04 SUBMITTAL REQUIREMENTS:

A. Required submittals shall include:

- (1) Shop drawings.
- (2) Piping layout.
- (3) Manufacturer’s Data.
- (4) Certificates of Warranty.
- (5) Any others as called for in the plans, specifications, or by the Engineer.

B. The Contractor’s stamp and verification of drawings shall consist of the following information:

CONTRACTOR NAME

PROJECT: **Makaleha On-Site Sodium Hypochlorite Generation Pilot Project**

JOB NO.: **19-03**

THIS SUBMITTAL HAS BEEN CHECKED BY THIS GENERAL CONTRACTOR. IT IS CERTIFIED CORRECT, AND IN COMPLIANCE WITH CONTRACT DRAWINGS AND SPECIFICATIONS. ALL AFFECTED CONTRACTORS AND SUPPLIERS ARE AWARE OF, AND WILL INTEGRATE THIS SUBMITTAL INTO THEIR OWN WORK.

DATE RECEIVED: _____
 SUBMITTAL NUMBER: _____
 SPECIFICATION SECTION: _____
 SPECIFICATION PARAGRAPH: _____
 DRAWING NUMBER: _____
 SUBCONTRACTOR NAME: _____
 SUPPLIER NAME: _____
 MANUFACTURER NAME: _____
 CERTIFIED BY: _____



- C. This stamp, “filled in”, should appear on the title sheet of each shop drawing, on a cover sheet of submittals in an 8½"x11" format, or on a one face of a cardstock tag (min. 3"x6") tied to each sample. The tag on samples should state what the sample is, so that, if the tag is accidentally separated from the sample, it can be matched up again.
- D. The person signing the Contractor’s submittal stamp shall be the person with authority to act for the Contractor in connection with the contract during the performance of the contract. The signature shall be in original ink. Stamped signature will not be acceptable.
- E. Prepare submittals to show that the material, equipment, or work shown is in accordance with contract requirements and has been checked for dimensions and relationship with work of all other trades involved. All deviations from the plans and specifications shall be noted.
- F. Approval shall extend only to general conformance and shall not relieve the Contractor from his or her responsibility for coordinating his or her work with other trades and complying with the provisions of the contract documents for lengths, fits, quality of materials, quantities, applicable code requirements and other details. Approval does not authorize changes from the contract requirements unless stated in a separate letter or change order.
- G. Submittals shall be made in sufficient time to allow the Engineer not less than twenty regular working days for examining the drawings. The Contractor shall make submittals at the earliest possible date after the Notice to Proceed date to meet the construction schedule. The Engineer will not consider delays caused by the Contractor’s failure to make submittals on time as justifiable reasons for contract time extensions.
- H. When the submittals have been reviewed by the Engineer, two sets of submittals will be returned to the Contractor appropriately stamped. If major changes or corrections are necessary, the submittal may be rejected and one set will be returned to the Contractor with such changes or corrections indicated, and the Contractor shall correct and resubmit six copies of the drawings, unless otherwise directed by the Engineer. No changes shall be made by the Contractor to the resubmitted shop drawings other than those changes indicated by the Engineer. The resubmittal shall be so indicated on the shop drawing.
- I. Prior to approval of such drawings, any work which the Contractor may do on fabrications covered by the same is at his or her own risk, as the County will not be responsible for any expense incurred by the Contractor for changes to make the same conform to the drawings as finally approved.
- J. Upon approval of the above drawings, lists, prints and other data, a copy of the same shall be kept with the job site plans, and the fabrications furnished shall be in conformance with the same. However, approval of above drawings, lists, prints, specifications and other data shall in no way release the Contractor from his or her responsibility for the proper fulfillment of the requirements of this contract nor for

fulfilling the purpose of the installation nor from his or her liability to replace the same should it prove defective or fail to meet the specified requirements.

K. Submittal Clarity:

(1) Drawings:

- a. Prepare finished drawings so that prints, reproducible, and reductions to half size will be clear and legible.
- b. Make free-hand lettering no less than 5/32 inch high and typewritten notes no less than 1/8 inch high to allow for reduction. Do not crowd lettering.

(2) Manufacturer's Literature:

- a. Submit a minimum of one original of manufacturer's printed material. Remaining number of submittals may be reproductions. Ensure reproductions of original materials are clear and legible.
- b. Clearly mark the item(s) and/or information applicable to this project with arrows, bubbles, etc. Do not use high-lighted markings.
- c. Provide the name and phone number of manufacturer's sales and service representative for each device submitted.

1.17.05 DEFINITION OF "SUBMITTALS FOR REVIEW":

- A. Catalog Data: Manufacturer's standard printed information on materials, products and systems, which shows performance characteristics, dimensions, material of fabrication, and other characteristics necessary to assure conformity with the design requirements. Where other items or information not related to the work of this project are included in the literature submitted, the item(s) and/or information applicable to this project shall be clearly marked.
- B. Shop Drawings: Drawings necessary to show fabrication details to ensure compliance with contract documents.
- C. Block Diagrams: Block Diagrams necessary to show system connections and details to ensure compliance with contract documents.
- D. Wiring Diagrams: Drawings showing the point-to-point or schematic wiring of a piece of equipment or between pieces of equipment in a system.
- E. Calculations: The methods and results of calculations in documented form where specified.
- F. Material / Parts List: A list of system components or material components.
- G. Samples / Colors: Samples, including colors, of proposed materials.

- H. Certifications: A written statement, signed by a qualified party, attesting that items or services are in accordance with specified requirements. Typically, this written statement is accompanied by additional information to substantiate the statement.
- I. Installation Instructions / Test Procedures: Manufacturer's instructions, step-by-step if necessary, showing the field installation and testing of parts, components, equipment, and other similar items.
- J. Test Reports: Results of specified test requirements.
- K. Meetings: Schedule, agenda, attendees, and location for required meetings and meeting notes.
- L. Other: Other submittal information as described in individual specification sections.

1.17.06 DEFINITION OF "SUBMITTALS FOR CLOSEOUT":

A. Operations and Maintenance (O&M) Manuals:

(1) Format:

a. Hardcopy: Three (3) full sets

- 1) Size: 8½"x11". Fold 11"x17" drawings to 8½"x11" size. Reduce drawings larger than 11"x17" format to 11"x17" format.
- 2) Binders: Use commercial quality expandable post binders meeting the following requirements:
 - (a) Binder Covers: 1/8" thick construction (minimum).
 - (b) Hinges: Continuous, metal piano hinge.
 - (c) Binder Expandability: 3½" – 5½".
 - (d) Sheet Size: 8½"x11".
 - (e) Binder Cover Material: Heavy vinyl.
 - (f) Binder Printing: Provide custom printed spine and front imprinted with the following information:

County of Kaua'i
 Department of Water
 (Print O&M manual titles and project title)

(g) Manufacturer's Reference: Specialty Loose Leaf, Inc.

- 3) Fill: Do not fill binders more than 75% full.
- 4) Indexed Tabs: Internally subdivide the binder contents with permanent page dividers, logically organized, with tab titling clearly printed under reinforced laminated plastic tabs.



- b. Adobe PDF Electronic Copy: Provide a copy of the O&M Manual in Adobe PDF Electronic Format on compact disk(s).
- c. Electronic Data: Provide electronic files on compact disk(s) of any material created electronically by Integrator, in file format in which document was created, that is, Microsoft Word, AutoCAD, etc., including but not limited to:
 - 1) Drawing Files.
 - 2) Installation Instructions.
 - 3) Software Documentation.
 - 4) Operating and Maintenance Instructions.
- d. Odd Sized Material: Where O&M information does not lend itself to incorporation into 8½"x11" format, such as the material listed, below, provide it separate from the O&M Manuals. However, clearly label each item, and provide reference in the O&M Manual to the material that is provided separate from the O&M Manuals.
 - 1) Edge-glued books or manuals without 3-hole punched binding.
 - 2) Material of a size other than 8½"x11".
 - 3) Compact disks in jewel cases.

(2) Contents:

- a. Table of Contents: Prepare a Table of Contents, for each volume, with each product or system description identified, and include with each volume of manual. Type on 24-pound white paper.
- b. Directory: Provide names, addresses, and telephone number of Prime Contractor, Integrator, Installation Contractor, other subcontractors, and major equipment suppliers. Clearly identify contact for warranty support.
- c. General: Provide operations and maintenance data for equipment described in the individual sections of the Specification. Prepare and include additional data when the need for such data becomes apparent during training.
- d. Description of System and Component Parts:
 - 1) System block and interconnection diagrams.
 - 2) Control diagrams by controls vendor and as-installed control drawing by Contractor.
 - 3) As-installed wiring diagrams, that is, ladder diagrams, point to point diagrams, loop diagrams, circuit directories of panel boards, and similar items.

- 4) Manufacturer's printed installation, operating, and maintenance instructions for the exact item of equipment supplied.
 - 5) Catalog data containing information required for service, future additions or substitutions.
 - 6) Function, normal operating characteristics, and limiting conditions.
 - 7) Performance curves, engineering data and tests.
 - 8) Complete nomenclature and commercial number of replaceable parts.
- e. System Operating Procedures:
- 1) Description of sequence of operation by control manufacturer.
 - 2) Routine and normal operating instructions.
 - 3) Sequences required.
 - 4) Special operating instructions.
- f. System and Equipment Maintenance Procedures:
- 1) Routine operations.
 - 2) Guide to "trouble-shooting"
 - 3) Disassembly, repair and reassembly.
 - 4) Alignment, adjusting and checking.
- g. Maintenance instructions for special finishes, including recommended cleaning methods and materials and special precautions identifying detrimental agents.
- h. Spare Parts List: List of manufacturer's spare parts provided with the job, manufacturer's current prices for spare parts, and recommended quantities to be maintained in storage.
- B. Project Record Documents: Provide Project Record Documents as required.
- C. Spare Parts / Maintenance Materials:
- (1) Provide products, spare parts, maintenance and extra materials in quantities specified in individual specification sections prior to Final Acceptance.
 - (2) Deliver to Project site and place in location as directed by the Department of Water. Contractor shall obtain receipt.
- D. Test Reports: Results of specified test requirements. Provide Table of Contents of test results and incorporate into Operation and Maintenance Manuals described above.
- E. Warranty Certificates:

- (1) For each item required by specific sections of this specification, provide a notarized warranty certificate.
- (2) Execute and assemble documents from subcontractors, suppliers, and manufacturer.
- (3) For each item of copyrighted software provide under this contract, provide a software license certificate naming the Department of Water as the licensee and stating the number of licenses provided.
- (4) Provide Table of Contents of software licenses and incorporate into Operation and Maintenance Manuals described above.

1.18 CONTRACTOR'S OPERATIONS: The Contractor must employ, insofar as possible, such methods and means of carrying out his work so as not to cause any interruption or interference to the Department of Water's or the landowner's operations. Where the Contractor's operations would result in interruptions which would hamper the operations, the Contractor shall coordinate his schedule of work with the Department of Water or the landowner, accordingly.

In the event that the Contractor obtains permission from the landowner for use of any area or resources outside of the designated lot(s), County Right-of-Way, State Highway's Right-of-Way, and/or designated easement(s), the Contractor shall meet the requirements of Division 300, Section 301.15 – USE AND/OR DAMAGE TO PRIVATE PROPERTY (PROPERTY OWNED OTHER THAN BY THE CONTRACTOR) of the Water System Standards, 2002.

END OF SECTION



CONTRACT NO. [Click here to enter text.](#)

CONSTRUCTION CONTRACT

THIS CONTRACT, effective as of the date below, is made and entered into by and between the BOARD OF WATER SUPPLY, County of Kaua'i, whose mailing address is 4398 Pua Loke Street, Līhu'e, Hawai'i 96766 (hereinafter the "BOARD") and [Click here to enter text.](#), a [Click here to enter text.](#), under the laws of the State of Hawaii, whose principle mailing address is [Click here to enter text.](#) (hereinafter the "CONTRACTOR").

RECITALS

THIS CONTRACT for construction services has been procured under:

- HRS §103D-302 (Competitive Sealed Bidding)
- HRS §103D-303 (Competitive Sealed Proposals)
- HRS §103D-305 (Small Purchase)
- HRS §103D-307 (Emergency Procurement No. [Click here to enter text.](#))

WHEREAS, ; and

WHEREAS, the Contractor is able and qualified to provide such construction services as required in this Contract; and

NOW THEREFORE, in consideration of the payment(s) hereinafter set forth to be made by the Board, the Contractor agrees to furnish and pay for all materials, supplies, tools, equipment, labor, utilities, transportation, services, and any and all other incidentals necessary to construct in place and complete, free of all liens, claims, and any encumbrances whatsoever: **Click here to enter text.** (hereinafter "Project").

1. **Contract Documents.** The Contractor agrees to complete the Project in accordance with this Contract and the following documents:

- Approved construction drawings;
- Specifications;
- Invitation for Bids Document No. [Click here to enter text.](#) and all Addenda thereto;
- Request for Proposals Project No. [Click here to enter text.](#) and all Addenda thereto;
- Bid/Proposal/Best and Final Offer;

- Method of Award;
- Wage Rate Schedule;
- Construction Schedules;
- Special Provisions;
- General Provisions for Construction Contracts of the Department of Water, dated April 25, 2016;

and those other documents attached or referred to therein, relating to the Project (hereinafter collectively referred to as "Contract Documents"). The Contractor understands and agrees that the Contract Documents including, but not limited to, those referenced in but not attached to this Contract and those referenced in but not attached to the Contract Documents, are hereby incorporated by reference into this Contract. The Contractor acknowledges and admits receipt of all Contract Documents, and acknowledges that it has reviewed, understands, and agrees with all terms and conditions in the Contract Documents and those other documents, terms and conditions referenced therein.

2. **Time of Performance.** The Contractor agrees to complete the Project within [Click here to enter text.](#) **CALENDAR DAYS**, from and including the date as specified in the written Notice to Proceed.

3. **Compensation.** For and in consideration of the Contractor's full and faithful performance of all services required to be performed under the Contract Documents, the Board hereby agrees to pay the Contractor the total maximum sum of [Click here to enter text.](#) **DOLLARS** ([\\$Click here to enter text.](#)), federal, state, and local taxes included, in lawful money of the United States of America. The Contractor understands and agrees that payment shall be made in the manner and at the times specified in the Contract Documents, and shall also be subject to and conditioned upon such additions to or deductions from the preceding sum as may herein be made, according to the Contract Documents.
 - a. **Cost and/or Pricing:** If this Contract required Cost and/or Pricing data, the Contractor understands and agrees that the price to the Board, including profit or fee, shall be adjusted to exclude any significant sums by which the Board finds that the price was increased because the Contractor furnished cost or pricing data that was inaccurate, incomplete, or not current as of the date agreed upon between the parties.

4. **Liquidated Damages.** The Contractor understands and agrees that time is an essential factor of this Contract, and that the Board will suffer material loss by reason of delays that may occur in the Contractor's performance of the work or any portions of the work within the time or times fixed in the Contract or any extensions thereto. When the Contractor is given notice of delay or nonperformance, as specified in the Termination for Default clause of this Contract, and fails to cure in the time specified, the Contractor shall pay to the Board, as liquidated damages for any such delays or nonperformance, the sum of **[Click here to enter text.](#) DOLLARS** (**[\\$Click here to enter text.](#)**), for each and every calendar day of delay or nonperformance from the day set for cure until either the Board reasonably obtains similar services if the Contract is terminated for default, or until

the Contractor provides the services if the Contractor is not terminated for default. The sums of each and every calendar day of delay or nonperformance shall be deducted from the Contract price. It is expressly stipulated by and between the Contractor and the Board that any such sums shall be deemed and taken to be liquidated damages for the Contractor's failure to perform within the specified time and not be in the nature of a penalty. To the extent that the Contractor's delay or nonperformance is excused under "excuse for nonperformance or delayed performance" of the Termination for Default clause of this Contract, liquidated damages shall not be due the Board. The Contractor remains liable for damages caused other than by delay.

5. **Bonds.** The Contractor is required to provide the following bonds, in an amount equal to 100% of the amount of the Contract price in the form(s) set forth in **Exhibit A**:

- Performance Bond (**Exhibit A1**)
- Labor and Material Payment Bond (**Exhibit A2**)
- Not Applicable

6. **Insurance.** Contractor shall procure and maintain, on a primary basis and at its sole expense, at all times during the life of the contract insurance coverages, limits, including endorsements as described Appendix "B" - Insurance, against claims for injuries to persons or damages to property which may arise from or in connection with the performance of the work by the Contractor or the Contractor's agents, representatives, employees, or subcontractors. The requirements contained therein, as well as the Department's review or acceptance of insurance maintained by the Contractor is not intended to and shall not in any manner limit or qualify the liabilities or obligations assumed by the Contractor. Unless otherwise approved by the Manager and Chief Engineer, the policy or policies of insurance maintained by the Contractor shall provide the minimum limit(s) and coverage(s) as specified in the attached Appendix "B" - Insurance and be placed with an insurance carrier authorized to do business in this state and rated A-VII by A.M. Best.

7. **Procurement Officer and Contract Administrator.** The Procurement Officer and Contract Administrator are:

If checked, the Procurement Officer and the Contract Administrator shall be the same individual.

Procurement Officer:

[Click here to enter text.](#)

[Click here to enter text.](#)

Department of Water, County of Kaua'i

4398 Pua Loke Street

Līhu'e, HI 96766

Phone: 808-245-[Click here to enter text.](#)

[Click here to enter text.](#)

Contract Administrator:

[Click here to enter text.](#)

[Click here to enter text.](#)

Department of Water, County of Kaua'i

4398 Pua Loke Street

Līhu'e, HI 96766

Phone: 808-245-[Click here to enter text.](#)

[Click here to enter text.](#)

8. **Severability.** In the event any term or provision of this Contract is declared to be invalid or illegal for any reason, this Contract will remain in full force and effect and will be interpreted as though such invalid or illegal provision were not a part of this Contract.
9. **Execution in Counterparts.** This Contract may be executed in counterparts, all of which shall be considered the same as if a single document shall have been executed, but shall become effective when such counterparts have been signed by each of the parties hereto and delivered to each party.
10. **Waiver.** Waiver of a breach or default under this Agreement shall not constitute a continuing waiver or a waiver of a subsequent breach of the same or any other provision of this Agreement.
11. **Board Defined.** As used in this Contract, “Board” means the Board of Water Supply of the County of Kaua‘i and the Department of Water, County of Kaua‘i, and its officers, agents, and employees.

[REMAINDER OF THIS PAGE INTENTIONALLY LEFT BLANK]

IN WITNESS WHEREOF, the parties hereto have hereunto caused this Contract to be executed as of the _____ day of _____, 20_____.

RECOMMENDED FOR APPROVAL

BOARD OF WATER SUPPLY,
COUNTY OF KAUA'I

Bryan Wienand, P.E.
Manager and Chief Engineer

Beth Tokioka
Chairperson, Board of Water Supply

APPROVED AS TO FORM
AND LEGALITY

CONTRACTOR

Mahealani M. Krafft
Deputy County Attorney

By: Click here to enter text.
Its: Click here to enter text.

STATE OF HAWAI'I)
) ss.
COUNTY OF KAUA'I)

On this ____ day of _____, 20____ in the Fifth Circuit, State of Hawai'i, before me personally appeared **Beth Tokioka**, who is personally known to me or whose identity I proved on the basis of satisfactory evidence, who being by me duly sworn or affirmed, did say that such person is the **Chairperson** for the **Board of Water Supply, County of Kaua'i** executed _____, dated _____ and consisting of ____ pages at the time of notarization, as the free act and deed of such person, and if applicable in the capacity shown, having been duly authorized to execute such instrument in such capacity.

Notary Public, State of Hawai'i
Name of Notary: _____ (Affix Seal)
My Commission expires: _____

STATE OF HAWAI'I)
) ss.
COUNTY OF KAUA'I)

On this ____ day of _____, 20____ in the Fifth Circuit, State of Hawai'i, before me personally appeared _____, who is personally known to me or whose identity I proved on the basis of satisfactory evidence, who being by me duly sworn or affirmed, did say that such person executed the _____, dated _____ and consisting of ____ pages at the time of notarization, as the free act and deed of such person, and if applicable in the capacity shown, having been duly authorized to execute such instrument in such capacity.

Notary Public, State of Hawai'i
Name of Notary: _____ (Affix Seal)
My Commission expires: _____

PLEASE INSERT YOUR APPLICABLE NOTARY SECTION

**EXHIBIT A1
PERFORMANCE BOND (SURETY)**

KNOW ALL BY THESE PRESENTS:

That Click here to enter text., a Click here to enter text. corporation, whose principal mailing address is Click here to enter text., as Principal, (hereinafter referred to as “Principal”), and Click here to enter text., as Surety, (hereinafter referred to as “Surety”), a corporation(s) authorized to transact business as a surety in the State of Hawai‘i, are held and firmly bound unto the Board of Water Supply, its successors and assigns, (hereinafter referred to as “Obligee”), in the amount of **Click here to enter text. DOLLARS (\$Click here to enter text.)** to which payment Principal and Surety bind themselves, their heirs, executors, administrators, successors and assigns, jointly and severally, firmly by these presents.

WHEREAS, the above-bound Principal has entered into a Contract with Obligee dated Click here to enter a date. for Click here to enter text. (hereinafter referred to as the “Contract”), which Contract is incorporated herein by reference and made a part hereof.

NOW THEREFORE, the condition of this obligation is such that:

If the Principal shall promptly and faithfully perform, and fully complete the Contract in strict accordance with the terms of the Contract as said Contract may be modified or amended from time to time; then this obligation shall be void; otherwise to remain in full force and effect. Surety to this bond hereby stipulates and agrees that no changes, extensions of time, alterations, or additions to the terms of the Contract, including the work to be performed thereunder, and the specifications or drawings accompanying same, shall in any way affect its obligation on this bond, and it does hereby waive notice of any such changes, extensions of time, alterations, or additions, and agrees that they shall become part of the Contract.

In the event of Default by the Principal, of the obligations under the Contract, then after written Notice of Default from the Obligee to the Surety and the Principal, Surety shall either remedy the Default, or take over the work to be performed under the contract and complete such work, subject, however, to the limitation of the penal sum of this bond.

Signed and sealed this _____ day of _____.

Principal Seal

By: _____

Its: _____

Surety Seal

By: _____

Its: _____

ALL SIGNATURES MUST BE ACKNOWLEDGED BY A NOTARY PUBLIC

SURETY PERFORMANCE BOND

STATE OF HAWAI'I)
) ss.
COUNTY OF KAUA'I)

On this _____ day of _____, _____, before me appeared _____ to me personally known, who being by me was duly sworn, did say he/she is the _____ of _____, a _____; that the seal affixed to the foregoing instrument is the _____ seal of said _____; and said officer acknowledged said instrument to be the free act and deed of said _____.

Notary Public, State of Hawai'i

Name of Notary: _____

My commission expires: _____

SURETY PLEASE INSERT YOUR APPLICABLE NOTARY SECTION

**EXHIBIT A1
PERFORMANCE BOND**

KNOW ALL BY THESE PRESENTS:

That we, _____, whose mailing address is _____, as Contractor, (hereinafter called "Contractor"), is held and firmly bound unto the _____, its successors and assigns, as Obligee, (hereinafter called "Obligee"), in the amount of _____ **DOLLARS (\$ _____)**, lawful money of the United States of America, for the payment of which to the said Obligee, well and truly to be made, Contractor binds itself, its heirs, executors, administrators, successors and assigns, firmly by these presents. Said amount is evidenced by:

- Legal tender;
- Share Certificate unconditionally assigned to or made payable at sight to _____;
- Certificate of Deposit, No. _____, dated _____, issued by _____, drawn on _____, a bank, savings institution, or credit union insured by the Federal Deposit Insurance Corporation or the National Credit Union Administration, payable at sight or unconditionally assigned to _____;
- Cashier's Check No. _____, dated _____, issued by _____, drawn on _____, a bank, savings institution, or credit union insured by the Federal Deposit Insurance Corporation or the National Credit Union Administration, payable at sight or unconditionally assigned to _____;
- Teller's Check No. _____, dated _____, issued by _____, drawn on _____, a bank, savings institution, or credit union insured by the Federal Deposit Insurance Corporation or the National Credit Union Administration, payable at sight or unconditionally assigned to _____;
- Treasurer's Check No. _____, dated _____, issued by _____;

_____, drawn on _____, a bank, savings institution, or credit union insured by the Federal Deposit Insurance Corporation or the National Credit Union Administration, payable at sight or unconditionally assigned to _____;

Official Check No. _____, dated _____, issued by _____, drawn on _____, a bank, savings institution, or credit union insured by the Federal Deposit Insurance Corporation or the National Credit Union Administration, payable at sight or unconditionally assigned to _____;

Certified Check No. _____, dated _____, issued by _____, drawn on _____, a bank, savings institution, or credit union insured by the Federal Deposit Insurance Corporation or the National Credit Union Administration, payable at sight or unconditionally assigned to _____.

WHEREAS, the Contractor has by written agreement dated _____ entered into a contract with Obligee for the following PROJECT: [Click here to enter text.](#), (hereinafter called the “Contract”), which Contract is incorporated herein by reference and made a part hereof.

NOW, THEREFORE,

The condition of this obligation is such that, if Contractor shall promptly and faithfully perform the Contract in accordance with, in all respects, the stipulations, agreements, covenants and conditions of the Contract as it now exists or may be modified according to its terms, and shall deliver the PROJECT to the Obligee, or to its successors or assigns, fully completed as in the Contract specified and free from all liens and claims and without further cost, expense, or charge to the Obligee, its officers, agents, successors, or assigns, free and harmless from all suits or actions of every nature and kind which may be brought for or on account of any injury or damage, direct or indirect, arising or growing out of the doing of said work or the repair or maintenance thereof or the manner of doing the same or the neglect of the Contractor or its agents or servants or the improper performance of the Contract by the Contractor or its agents or servants or from any other cause, then this obligation shall be void; otherwise it shall be and remain in full force and effect.

AND IT IS HEREBY STIPULATED AND AGREED that suit on this bond may be

brought before a court of competent jurisdiction without a jury, and that the sum or sums specified in the said Contract as liquidated damages, if any, shall be forfeited to the Oblige, its successors or assigns, in the event of a breach of any, or all, or any part of, the covenants, agreements, conditions, or stipulations contained in the Contract or in this bond in accordance with the terms thereof.

The amount of this bond may be reduced by and to the extent of any payment or payments made in good faith hereunder.

Signed this ____ day of _____, _____.

(Seal)

Name of Contractor

Signature

Title

STATE OF HAWAI'I)
) ss.
_____)

On this _____ day of _____, _____, before me appeared _____ to me personally known, who being by me was duly sworn, did say he/she is the _____ of _____, a _____; that the seal affixed to the foregoing instrument is the _____ seal of said _____; and said officer acknowledged said instrument to be the free act and deed of said _____.

Notary Public, State of Hawai'i

Name of Notary: _____

My commission expires: _____

ALL SIGNATURES MUST BE ACKNOWLEDGED BY A NOTARY PUBLIC

EXHIBIT A2
LABOR AND MATERIAL PAYMENT BOND (SURETY)

KNOW ALL BY THESE PRESENTS:

That Click here to enter text. a Click here to enter text. corporation, whose principal mailing address is Click here to enter text. , as principal (hereinafter referred to as "Principal"), and Click here to enter text. as Surety (hereinafter referred to as "Surety"), a corporation(s) authorized to transact business as a surety in the State of Hawai'i, are held and firmly bound unto the Board of Water Supply, its successors and assigns (hereinafter referred to as "Obligee"), in the amount of Click here to enter text. **DOLLARS** (\$Click here to enter text.), to which payment Principal and Surety bind themselves, their heirs, executors, administrators, successors and assigns, jointly and severally, firmly by these presents.

WHEREAS, the above-bound Principal has entered into a Contract with Obligee dated Click here to enter a date. for Click here to enter text. (hereinafter referred to as the "Contract"), which Contract is incorporated herein by reference and made a part hereof.

NOW, THEREFORE, the condition of this obligation is such that if the Principal shall promptly make payment to any Claimant, as hereinafter defined, for all labor and materials supplied to the Principal for use in the performance of the Contract, then this obligation shall be void; otherwise to remain in full force and effect.

1. Surety to this Bond hereby stipulates and agrees that no changes, extensions of time, alterations, or additions to the terms of the Contract, including the work to be performed thereunder, and the specifications or drawings accompanying same, shall in any way affect its obligation on this bond, and it does hereby waive notice of any such changes, extensions of time, alterations, or additions, and agrees that they shall become part of the Contract.
2. A "Claimant" shall be defined herein as any person who has furnished labor or materials to the Principal for the work provided in the Contract.

As provided in Section 103D-324, Hawai'i Revised Statutes, every Claimant who has not been paid in full before the expiration of a period of ninety days after the day on which the last of the labor was done or performed or material was furnished or supplied, for which such a claims made, may institute an action against the Principal or the Principal and its Surety, on this bond

and have their rights and claims adjudicated in the action, and judgment rendered thereon; subject to the Obligee's priority on the bond. If the full amount of the liability of the Surety on the bond is insufficient to pay the full amount of the claims, then after paying the full amount due the Obligee, the remainder shall be distributed pro rata among the claimants.

Signed and sealed this _____ day of _____.

Principal Seal

By: _____

Its: _____

Surety Seal

By: _____

Its: _____

ALL SIGNATURES MUST BE ACKNOWLEDGED BY A NOTARY PUBLIC

SURETY LABOR AND MATERIAL PAYMENT BOND

STATE OF HAWAI'I)
) ss.
_____)

On this _____ day of _____, _____, before me appeared _____ to me personally known, who being by me was duly sworn, did say he/she is the _____ of _____, a _____; that the seal affixed to the foregoing instrument is the _____ seal of said _____; and said officer acknowledged said instrument to be the free act and deed of said _____.

Notary Public, State of Hawai'i

Name of Notary: _____

My commission expires: _____

SURETY PLEASE INSERT YOUR APPLICABLE NOTARY SECTION

EXHIBIT A2
LABOR AND MATERIAL PAYMENT BOND
(11/17/98)

KNOW ALL BY THESE PRESENTS:

That we, _____, whose mailing address is _____, as Contractor, (hereinafter called "Contractor"), is held and firmly bound unto the _____, its successors and assigns, as Obligee, (hereinafter called "Obligee"), in the amount of _____ **DOLLARS** (\$_____), lawful money of the United States of America, for the payment of which to the said Obligee, well and truly to be made, Contractor binds itself, its heirs, executors, administrators, successors and assigns, firmly by these presents. Said amount is evidenced by:

- Legal tender;
- Share Certificate unconditionally assigned to or made payable at sight to _____;
- Certificate of Deposit, No. _____, dated _____, issued by _____, drawn on _____, a bank, savings institution, or credit union insured by the Federal Deposit Insurance Corporation or the National Credit Union Administration, payable at sight or unconditionally assigned to _____;
- Cashier's Check No. _____, dated _____, issued by _____, drawn on _____, a bank, savings institution, or credit union insured by the Federal Deposit Insurance Corporation or the National Credit Union Administration, payable at sight or unconditionally assigned to _____;
- Teller's Check No. _____, dated _____, issued by _____, drawn on _____, a bank, savings institution, or credit union insured by the Federal Deposit Insurance Corporation or the National Credit Union Administration, payable at sight or unconditionally assigned to _____;
- Treasurer's Check No. _____, dated _____, issued by _____;

_____, drawn on _____, a bank, savings institution, or credit union insured by the Federal Deposit Insurance Corporation or the National Credit Union Administration, payable at sight or unconditionally assigned to _____;

Official Check No. _____, dated _____, issued by _____, drawn on _____, a bank, savings institution, or credit union insured by the Federal Deposit Insurance Corporation or the National Credit Union Administration, payable at sight or unconditionally assigned to _____;

Certified Check No. _____, dated _____, issued by _____, drawn on _____, a bank, savings institution, or credit union insured by the Federal Deposit Insurance Corporation or the National Credit Union Administration, payable at sight or unconditionally assigned to _____.

WHEREAS:

The Contractor has by written agreement dated [Click here to enter a date.](#) entered into a contract with Obligee for the following PROJECT: [Click here to enter text.](#), (hereinafter called “Contract”), which Contract is incorporated herein by reference and made a part hereof.

NOW, THEREFORE,

The condition of this obligation is such that, if Contractor shall promptly and faithfully perform the Contract in accordance with, in all respects, the stipulations, agreements, covenants and conditions of the Contract as it now exists or may be modified according to its terms, free from all liens and claims and without further cost, expense or charge to the Obligee, its officers, agents, successors or assigns, free and harmless from all suits or actions of every nature and kind which may be brought for or on account of any injury or damage, direct or indirect, arising or growing out of the doing of said work or the repair or maintenance thereof or the manner of doing the same or the neglect of the Contractor or its agents or servants or the improper performance of the Contract by the Contractor or its agents or servants or from any other cause, and shall promptly pay all persons supplying labor and materials for the performance of the Contract, then this obligation shall be void; otherwise it shall be and remain in full force and effect.

AND IT IS HEREBY STIPULATED AND AGREED that suit on this bond may be

brought before a court of competent jurisdiction without a jury, and that the sum or sums specified in the said Contract as liquidated damages, if any, shall be forfeited to the Obligee, its successors or assigns, in the event of a breach of any, or all, or any part of, the covenants, agreements, conditions, or stipulations contained in the Contract or in this bond in accordance with the terms thereof.

AND IT IS HEREBY STIPULATED AND AGREED that this bond shall inure to the benefit of any and all persons entitled to file claims for labor performed or materials furnished in said work so as to give any and all such persons a right of action as contemplated by Sections 103D-324(d) and 103D-324(e), Hawai'i Revised Statutes.

The amount of this bond shall be reduced by and to the extent of any payment or payments made in good faith hereunder, inclusive of the payment of mechanics' liens which may be filed of record against the PROJECT, whether or not claim for the amount of such lien be presented under and against this bond.

Signed this ____ day of _____, _____.

(Seal)

Name of Contractor

Signature

Title

ALL SIGNATURES MUST BE ACKNOWLEDGED BY A NOTARY PUBLIC

STATE OF HAWAI'I)
) ss.
_____)

On this _____ day of _____, _____, before me appeared _____ to me personally known, who being by me was duly sworn, did say he/she is the _____ of _____, a _____; that the seal affixed to the foregoing instrument is the _____ seal of said _____; and said officer acknowledged said instrument to be the free act and deed of said _____.

Notary Public, State of Hawai'i

Name of Notary: _____

My commission expires: _____

EXHIBIT B
Placeholder

GENERAL PROVISIONS

FOR

CONSTRUCTION CONTRACTS

OF THE

DEPARTMENT OF WATER

COUNTY OF KAUA‘I
STATE OF HAWAI‘I

April 25, 2016

**GENERAL PROVISIONS
OF
CONSTRUCTION CONTRACTS
OF THE
DEPARTMENT OF WATER
COUNTY OF KAUA'I**

April 25, 2016

Table of Contents

SECTION 1 - DEFINITIONS	8
1.1 ADDENDUM/ADDENDA	8
1.2 BOARD	8
1.3 BID	8
1.4 BIDDER	8
1.5 BID SECURITY	8
1.6 CALENDAR DAY	8
1.7 CHANGE ORDER	8
1.8 CHIEF PROCUREMENT OFFICER	8
1.9 CONTRACT	8
1.10 CONTRACT TIME	9
1.11 CONTRACTING OFFICER	9
1.12 CONTRACTOR	9
1.13 COST ANALYSIS	9
1.14 COST DATA	9
1.15 DAYS	9
1.16 DEPARTMENT	9
1.17 EXTENDED OVERHEAD	9
1.18 FINAL PROPOSAL	9
1.19 GUARANTEE	9
1.20 HAR	9
1.21 HAZARDOUS MATERIALS	9
1.22 HAZARDOUS MATERIALS LAWS	10
1.23 HRS	10

1.24	INVITATION FOR BIDS or IFB	10
1.25	MANAGER	10
1.26	NOTICE TO PROCEED or NTP	10
1.27	OFFER	10
1.28	OFFEROR	10
1.29	OVERHEAD	10
1.30	PERSON	10
1.31	PRICE ANALYSIS	10
1.32	PRICE DATA	10
1.33	PROPOSAL	11
1.34	PROPOSER	11
1.35	REFERENCE SPECIFICATIONS	11
1.36	REQUEST FOR PROPOSALS or RFP	11
1.37	RESPONSIBLE OFFEROR	11
1.38	RESPONSIVE BIDDER or OFFEROR	11
1.39	SOLICITATION	11
1.40	STATE	11
1.41	WARRANTY	11
1.42	WORKING DAY	11
1.43	OTHER REFERENCES	12
SECTION 2 - BIDDING/PROPOSAL INSTRUCTIONS.....		14
2.1	DEPOSIT FOR PLANS, SPECIFICATIONS AND SPECIAL PROVISIONS	14
2.2	QUALIFICATIONS OF OFFERORS	14
2.3	CERTIFICATION OF HEALTH AND SAFETY	15
2.4	DETERMINATION OF RESPONSIBILITY	15
2.5	OFFER FORM	16
2.6	OFFER FORM, INTERPRETATION OF	16
2.7	PRICES TO COVER ENTIRE CONTRACT	17
2.8	COST AND PRICING DATA- PROPOSALS/Sole Source	17
2.9	BID SECURITY	18
2.10	PUBLIC OPENING OF BIDS	18
2.11	RECEIPT AND REGISTRATION OF PROPOSALS	19
2.12	EXAMINATION OF PLANS, SPECIFICATIONS, SPECIAL PROVISIONS AND SITE	19
2.13	TRADE NAMES AND ALTERNATIVES	20

2.14	PREFERENCES	20
2.15	MODIFICATION OR WITHDRAWAL OF OFFERS	20
2.16	LISTING OF JOINT CONTRACTORS AND SUBCONTRACTORS ..	21
2.17	BIDS, DISQUALIFICATION OF	22
2.18	PROPOSAL, DISQUALIFICATION OF	23
2.19	OFFEROR LIMITED ACCEPTANCE	23
2.20	MISTAKES IN BIDS	23
2.21	DISCUSSIONS WITH OFFERORS-REQUEST FOR PROPOSALS ..	25
SECTION 3	- AWARD AND EXECUTION OF CONTRACT.....	26
3.1	AWARD OF CONTRACT	26
3.2	CANCELLATION OF SOLICITATION OR AWARD	26
3.3	FUNDS, AVAILABILITY OF	26
3.4	ENTERING INTO CONTRACT	27
3.5	RESPONSIBILITY OF OFFERORS AND TAX CLEARANCE	27
3.6	PERFORMANCE AND PAYMENT BONDS	28
3.7	CAMPAIGN CONTRIBUTIONS BY STATE AND COUNTY CONTRACTORS	30
3.8	EMPLOYMENT OF STATE RESIDENTS ON CONSTRUCTION PROCUREMENT CONTRACTS	30
3.9	HAWAII PROCUREMENT LAW	30
SECTION 4	- LEGAL RELATIONS AND RESPONSIBILITY.....	31
4.1	AUTHORITY OF THE CONTRACTING OFFICER	31
4.2	INDEPENDENT CONTRACTOR	31
4.3	LAWS, REGULATIONS	32
4.4	PERMITS, LICENSES	33
4.5	NO PERSONAL LIABILITY	33
4.6	COORDINATION OF SPECIAL PROVISIONS, PLANS, SPECIFICATIONS, GENERAL PROVISIONS, WATER STANDARDS, AND OTHER PARTS OF THE CONTRACT DOCUMENTS	33
SECTION 5	- SCOPE OF CONTRACT.....	34
5.1	SCOPE OF CONTRACT	34
5.2	REQUESTS FOR INFORMATION	34
5.3	MODIFICATIONS TO THE WORK	35
5.4	PRICE ADJUSTMENT	37
5.5	DIFFERING SITE CONDITIONS	38

5.6	ASSIGNMENT, CHANGE OF NAME, NOVATION	38
5.7	VALUE ENGINEERING INCENTIVE	39
5.8	SUBSTITUTIONS	43
5.9	EXTRA WORK	44
5.10	PAYMENT FOR DELETED MATERIALS	44
SECTION 6	- PERFORMANCE OF CONTRACT	45
6.1	TIME	45
6.2	PERFORMANCE SCHEDULE	45
6.3	OWNER-CONTRACTOR MEETING, FIELD OFFICE AND FIELD TELEPHONE	46
6.4	DOCUMENTS TO BE KEPT ON SITE	47
6.5	ADDITIONAL PLANS AND SPECIFICATIONS TO BE FURNISHED BY THE CONTRACTING OFFICER	47
6.6	DRAWINGS TO BE FURNISHED BY CONTRACTOR	47
6.7	OMISSION IN CONTRACT	48
6.8	CONTRACTOR TO REPORT ERRORS OR DISCREPANCIES	48
6.9	CONTROL OF THE CONTRACT	48
6.10	PERSONAL SUPERVISION	51
6.11	CHARACTER OF WORKMEN, METHODS AND EQUIPMENT	51
6.12	WAGES AND HOURS	52
6.13	CONTRACTOR'S ADDRESS	53
6.14	OBSTRUCTIONS	53
6.15	SURVEYS AND CONSTRUCTION STAKES, LINES AND GRADES	54
6.16	SUBCONTRACTING	54
6.17	OTHER CONTRACTS	54
6.18	WATER REMOVAL	54
6.19	ELECTRICAL, TELECOMMUNICATION AND WATER SERVICE	54
6.20	UTILITIES UNDERGROUND	55
6.21	QUALITY OF MATERIALS AND EQUIPMENT	55
6.22	NATIONAL SANITATION FOUNDATION (NSF) APPROVALS	56
6.23	SAMPLES	56
6.24	PROTECTION OF PEDESTRIANS AND VEHICULAR TRAFFIC	56
6.25	ACCESS TO PROPERTY	58
6.26	PROJECT SIGN	58
6.27	PROJECT MAY BE PLACED IN SERVICE	58
6.28	PRECAUTIONS AND RESTORATION	59

6.29	MAINTENANCE OF SITE, CONTROL OF DUST, AND FINAL CLEANUP	66
6.30	RESPONSIBILITY OF THE CONTRACTOR PRIOR TO ACCEPTANCE	66
6.31	FINAL INSPECTION	67
6.32	FINAL COMPLETION AND FINAL ACCEPTANCE	67
6.33	GUARANTEE OF WORK	69
6.34	CLOSING CONTRACTS	69
SECTION 7 - PAYMENT.....		70
7.1	PAYMENT	70
7.2	VARIATIONS IN ESTIMATED QUANTITIES	70
7.3	QUANTITIES AND MEASUREMENTS	71
7.4	FORCE ACCOUNT	71
7.5	PAYMENTS DURING PERFORMANCE OF WORK	77
7.6	PAYMENT FOR DELIVERED MATERIALS	77
7.7	FINAL INSPECTION - FINAL PAYMENT	78
7.8	PROMPT PAYMENT BY CONTRACTORS TO SUBCONTRACTORS ..	78
SECTION 8 - REMEDIES.....		82
8.1	DISPUTES	82
8.2	CLAIMS BASED ON ORAL DIRECTIVES	82
8.3	DEFAULT, DELAY AND TIME EXTENSIONS	83
8.4	SUSPENSION OF WORK	85
8.5	TERMINATION OF CONTRACT - WORK MAY BE TAKEN OVER BY DEPARTMENT	86
8.6	TERMINATION FOR CONVENIENCE	88
8.7	COSTS OF COMPLETING CONTRACT	90
8.8	DAMAGES FOR DELAY	90
8.9	DAMAGES FOR EXTRA EXPENSES IMPOSED ON DEPARTMENT .	90
8.10	DEFECTIVE WORK	90
8.11	UNAUTHORIZED PERFORMANCE	90
8.12	AUTHORITY TO WITHHOLD MONEY DUE OR PAYABLE	91
8.13	SPECIAL EMERGENCY TERMINATION	91
8.14	REMEDIES NOT EXCLUSIVE	92
8.15	REMEDIES	92
EXHIBIT A - SURETY [BID][PROPOSAL] BOND.....		93

EXHIBIT B - PERFORMANCE BOND (SURETY).....	94
EXHIBIT C - PERFORMANCE BOND.....	95
EXHIBIT D - LABOR AND MATERIAL PAYMENT BOND (SURETY).....	97
EXHIBIT E - LABOR AND MATERIAL PAYMENT BOND.....	98
EXHIBIT F - PERFORMANCE BOND (SURETY) FOR SUPPLEMENTAL AGREEMENT FOR GOODS AND SERVICES.....	100
EXHIBIT G- PERFORMANCE BOND FOR SUPPLEMENTAL AGREEMENT FOR GOODS AND SERVICES.....	101
EXHIBIT H - CONTRACTOR ACKNOWLEDGMENT.....	103
EXHIBIT I - SURETY ACKNOWLEDGMENT.....	104
EXHIBIT J - SAMPLE CONTRACT.....	105
EXHIBIT K - CONTRACT CHANGE ORDER.....	127
EXHIBIT L - CONTRACT MODIFICATION FORM.....	128
EXHIBIT M - AS BUILT INFORMATION REQUIRED.....	129
EXHIBIT N - BMP INSPECTION FORM.....	131
EXHIBIT O - EMPLOYMENT OF STATE RESIDENTS COMPLIANCE FORM.....	136
EXHIBIT P - REQUEST FOR INFORMATION (RFI) FORM.....	137

**DEPARTMENT OF WATER
COUNTY OF KAUA‘I
STATE OF HAWAI‘I**

**GENERAL PROVISIONS OF CONSTRUCTION CONTRACTS
OF THE DEPARTMENT OF WATER, COUNTY OF KAUA‘I**

SECTION 1 - DEFINITIONS

When used in these provisions or elsewhere in the contract, the following terms, or pronouns used in place of them, shall have the meaning ascribed to them in this section, unless it is apparent from the context that a different meaning is intended:

- 1.1 ADDENDUM/ADDENDA** means a written document issued during the solicitation period involving changes to the solicitation documents which shall be considered and made a part of the solicitation documents and resulting contract [HAR 3-122-16.06].
- 1.2 BOARD** means the Board of Water Supply, County of Kaua‘i and the Department of Water County of Kaua‘i, its officers and employees.
- 1.3 BID** is as described in Hawai‘i Revised Statutes 103D-302.
- 1.4 BIDDER** means person or entity that has submitted a bid in response to the Department of Water, County of Kaua‘i’s Invitation for Bids.
- 1.5 BID SECURITY** means security provided at the time an offer is submitted.
- 1.6 CALENDAR DAY** means days shown on the calendar beginning at midnight and ending at midnight of the following day. If no designation of calendar or working day is made, “Day” shall mean calendar day.
- 1.7 CHANGE ORDER** means an amendment or modification of the work within the scope of the Contract, by the Contracting Officer or his/her authorized designee, directing the Contractor to make changes with or without the consent of the Contractor. [HRS 103D-104] [HAR 3-125-2][HAR 3-125-4]
- 1.8 CHIEF PROCUREMENT OFFICER** means the Manager and Chief Engineer of the Department.
- 1.9 CONTRACT** means the written agreement covering the construction of the project by the contractor, including the furnishing of labor, materials and equipment in connection therewith. It shall include these provisions, the contract and/or agreement, the notice to the bidders or proposers, the offer, the award, the special provisions, the plans, the specifications, the bond, any addendum and any written order. It shall also include all amendments to the contract by supplemental agreement thereto in writing.

1.10 CONTRACT TIME means the number of calendar days provided in the contract for completion of the contract, exclusive of authorized time extensions. The contract time will be indicated in the bid or proposal document and contract.

If the contract requires completion by a certain date, the contractor shall complete the work by that date.

1.11 CONTRACTING OFFICER means the Procurement Officer or Contract Administrator, or Construction Project Management Officer of the Department of Water, County of Kaua‘i or his or her duly authorized representative.

1.12 CONTRACTOR means the person who has entered into the contract with the Department and further defined by Section 444-1(2), HRS, as amended.

1.13 COST ANALYSIS means the evaluation of cost data for the purpose of arriving at costs actually incurred or estimates of costs to be incurred, prices to be paid, and costs to be reimbursed. [HAR 3-120-2]

1.14 COST DATA means information concerning the actual or estimated cost of labor, material, overhead, and other cost elements which have been actually incurred or which are expected to be incurred by the contractor in performing the contract. [HAR 3-120-2]

1.15 DAYS means consecutive calendar days unless otherwise specified. [HAR 3-120-2]

1.16 DEPARTMENT means the Department of Water, County of Kaua‘i, its officers and employees.

1.17 EXTENDED OVERHEAD includes project field office rental, salaries of field office and management staff, field office staff vehicles, field office utilities and telephone, and field office consumables, project fees, project bonding, project insurances and all taxes including general excise tax.

1.18 FINAL PROPOSAL means the final mutually-agreed terms of the proposal submitted by the awarded Offeror in response to the County’s RFP or the Best and Final Offer accepted by the County in accordance with HAR §3-122-53 and 3-122-54.

1.19 GUARANTEE means a formal assurance of the quality or of the length of use to be expected from a product offered or constructed.

1.20 HAR means the Hawai‘i Administrative Rules of the State of Hawai‘i, as amended.

1.21 HAZARDOUS MATERIALS mean and include any and all radioactive materials, asbestos, organic compounds known as polychlorinated biphenyls, chemicals known to cause cancer or reproductive toxicity, hazardous wastes, toxic substances, and any and all other substances or materials defined as “hazardous materials,” “extremely hazardous materials,” “hazardous wastes” or “toxic substances” under or for the purposes of hazardous materials laws.

- 1.22 HAZARDOUS MATERIALS LAWS** mean and include all federal, state or local laws, ordinances, rules, regulations or codes, now or hereafter in effect, relating to environmental conditions, human health or industrial hygiene, including but not limited to the Comprehensive Environmental Response, Compensation and Liability Act of 1980, as amended, 42 U.S.C. section 9601, et seq., the Resource Conservation and Recovery Act, 42, U.S.C. section 6901, et seq., the Hazardous Materials Transportation Act, 42 U.S.C. section 1801, et seq., the Clean Water Act, 33 U.S.C. section 1251 et seq., the Clean Air Act, 42 U.S.C. 7401 et seq., the Toxic Substances Control Act, 15 U.S.C. section 2601 - 2629, the Safe Drinking Water Act, 42, U.S.C. sections 300f - 300j, HRS Chapter 128D, Environmental Response Law, HRS Chapter 342B, Air Pollution Control, HRS Chapter 342D, Water Pollution, HRS Chapter 342H, Solid Waste Pollution, HRS Chapter 342J, Hazardous Waste, HRS Chapter 342L, Underground Storage Tanks, Chapter 342P, Asbestos, and any similar state or local laws or ordinances and the regulations now in effect or hereafter adopted, published or promulgated thereto.
- 1.23 HRS** means the Hawai‘i Revised Statutes of the State of Hawai‘i, as amended.
- 1.24 INVITATION FOR BIDS or IFB** means all documents, whether attached or incorporated by reference, utilized for soliciting bids under the competitive sealed bidding source selection method. [HAR 3-120-2]
- 1.25 MANAGER** means the Manager and Chief Engineer of the Department or his or her duly authorized representative.
- 1.26 NOTICE TO PROCEED or NTP** means the document issued to the Contractor designating the official commencement date of the performance under the Contract.
- 1.27 OFFER** refers to bidders and/or proposers.
- 1.28 OFFEROR** refers to bidders and/or proposers.
- 1.29 OVERHEAD** includes office expense, staff salaries, travel expenses, legal expenses, fees, insurances, bonding and all taxes including general excise tax.
- 1.30 PERSON** means an individual, a partnership, joint venture, a corporation, whichever is applicable.
- 1.31 PRICE ANALYSIS** means the evaluation of price data, without analysis of the separate cost components and profit as in cost analysis, which may assist in arriving at prices to be paid and costs to be reimbursed. [HAR 3-120-2]
- 1.32 PRICE DATA** means factual information concerning prices, including profit, for goods, services, or construction substantially similar to those being procured. In this definition, “prices” refers to offered or proposed selling prices, historical selling prices, and current selling prices of such items. This definition refers to data relevant to both the general contractor and subcontract prices. [HAR-3-120-2]

1.33 PROPOSAL means the executed document submitted by an Offeror in response to a Request for Proposals. [HAR 3-120-2].

1.34 PROPOSER means person or entity that has submitted an offer in response to the Department of Water, County of Kaua'i's Invitation for Bids or Request for Proposal.

1.35 REFERENCE SPECIFICATIONS means the most recently adopted and published edition of such specifications referred to on the date of the notice to bidders or proposers is contemplated, unless otherwise specified.

References are on file at the Department of Water for review by prospective bidders or proposers. Upon request, copies of a section or sections of the references will be made available pursuant to the Kaua'i County Code on reproducible charges for public records.

1.36 REQUEST FOR PROPOSALS or RFP means all documents, whether attached or incorporated by reference, utilized for soliciting proposals under the competitive sealed proposal source selection method. [HAR 3-120-2]

1.37 RESPONSIBLE OFFEROR means a person who has the capability in all respects to perform fully the Contract requirements, and the integrity and reliability which will assure good faith performance. [HRS 103D-104]

1.38 RESPONSIVE BIDDER or OFFEROR means a person who has submitted an offer which conforms in all material respects to the IFB or RFP. [HAR 3-120-2]

1.39 SOLICITATION means an invitation for bids, request for proposals, or a request for quotations, or any other document issued by the County for the purpose of soliciting bids or proposals to perform a County contract. [HAR 3-120-2]

1.40 STATE means the State of Hawai'i.

1.41 WARRANTY means a written statement that promises the good condition of a product and states that the maker is responsible for repairing or replacing the product for a certain period of time after its purchase.

1.42 WORKING DAY means a calendar day, exclusive of: (1) Saturdays, Sundays and State recognized legal holidays, (2) days during which the Contractors required to suspend construction operations, and (3) days on which weather and other conditions not under the control of the contractor will not permit construction operations to proceed for at least 5 hours of the day. The contractor shall perform the controlling item or items of work.

1.43 OTHER REFERENCES

A. Abbreviations.

The following abbreviations shall refer to the technical society, organization, body, code, rules or standard, listed opposite each abbreviation:

AASHTO	American Association of State Highway and Transportation Officials
ACI	American Concrete Institute
AGC	Associated General Contractors of America
AIA	American Institute of Architects
AISC	American Institute of Steel Construction
AISI	American Iron and Steel Institute
ANSI	American National Standards Institute
ASCE	American Society of Civil Engineers
ASTM	American Society for Testing and Materials
AWWA	American Water Works Association
AWRA	American Water Resources Association
HRS	Hawai'i Revised Statutes
HAR	Hawai'i Administrative Rules
IANPO	International Association of Plumbing & Mechanical Officials
MUTCD	Manual on Uniform Traffic Control Devices
NEC	National Electric Code
NEMA	National Electric Manufacturers Association
NSF	National Sanitation Foundation
UL	Underwriter's Laboratory
USGS	U.S. Geological Survey

B. **Standard Detail Drawings, Water Standards, Specifications and Special Provisions.**

When reference is made to standard detail drawings, Water Standards, specifications or special provisions, such referral shall be to the standard detail drawings, Water Standards, specifications or special provisions of the Department of Water, as amended.

Water Standards shall mean the “Water System Standards, State of Hawai‘i, 2002”, as amended, as adopted by Department of Water, County of Kaua‘i; Board of Water Supply, City and County of Honolulu; Department of Water Supply, County of Maui; and Department of Water Supply, County of Hawai‘i.

SECTION 2 – BIDDING/PROPOSAL INSTRUCTIONS

2.1 DEPOSIT FOR PLANS, SPECIFICATIONS AND SPECIAL PROVISIONS

Plans, Specifications and Special Provisions of the contract may be obtained from the Department of Water, Līhu‘e, Kaua‘i, upon deposit of the amount specified in the Notice to Bidders or Notice of the Request for Proposals.

Unless otherwise stated in the Notice to Bidders or the Notice of the Request for Proposals, the deposit for the plans, specifications and special provisions will be refunded upon their return in good condition to the Department of Water within thirty (30) calendar days after the day on which bids or proposals have been opened.

Deposits shall be forfeited if the plans, specifications and special provisions are not returned within the specified time or in good condition. The plans and specifications shall not, under any circumstances be disassembled. Should the Department discover any evidence of disassembling upon the return of the plans and specifications, the deposit on said plans and specifications shall be forfeited to the Department.

The sample form of the bid or proposal shall not be detached from the Special Provisions.

2.2 QUALIFICATIONS OF OFFERORS

All offerors shall be contractors licensed in accordance with Chapter 444, Hawai‘i Revised Statutes, as amended, to perform the work under the contract.

No contract will be awarded to any person who has been suspended under and as provided in, the provisions of Chapter 104, Hawai‘i Revised Statutes, Chapter 126, Subtitle 11, Title 3, Hawai‘i Administrative Rules and HRS 103D-702, or to any firm in which such suspended person has an interest.

Qualifications of Offerors. Prospective offerors must be capable of performing the work for which solicitations are being called. Each prospective offeror must file a written notice of intention to bid or propose which shall be received not less than ten (10) calendar days prior to the day designated for opening of bids or proposals. If the tenth calendar day prior to the day designated for opening of bids or proposals is a Saturday, Sunday, or legal State holiday, the written notice must be received by the Manager no later than 4:30 p.m. on the working day immediately before said Saturday, Sunday, or legal State holiday.

Prospective offerors shall, upon request, prove to the Manager his or her responsibility by showing, among other things, his or her experience in handling the class of service, article, material or machinery to be furnished and delivered, and that he or she possesses or is in a position financially and otherwise to secure and pay for said service, article, machinery or material by submitting answers under oath to all questions contained in the “Standard Qualification Questionnaire for Prospective Offerors on Department of Water Contracts” as

required by Section 103D-310, Hawai'i Revised Statutes, as amended, to the Department not less than ten (10) calendar days prior to the day fixed for the opening of the bids or proposals.

All information contained in answers to the questionnaire shall be and remain confidential. Questionnaires so submitted shall be returned to such offerors after having served their purpose. (Auth: 3-122-108 HAR)

2.3 CERTIFICATION OF HEALTH AND SAFETY

a) The Contractor shall give notices and comply with applicable laws, ordinances, rules, regulations and lawful orders of public authorities bearing on safety of persons or property or their protection from damage, injury or loss. The cost of Safety and Health shall not be paid for directly but shall be considered incidental and included in the prices bid for the various items of work.

b) Safety and Health Certificate of Compliance. A certificate of compliance shall be submitted with each offer certifying that, if awarded the contract, the offeror will comply with Section 396-18, HRS, relating to safety and health programs for County construction projects, where the offer amount is in excess of \$100,000. The certificate of compliance shall be submitted with the offer. Failure to submit the required certification shall be grounds for disqualification of the offer.

2.4 DETERMINATION OF RESPONSIBILITY

The Contracting Officer shall determine, on the basis of available information collected, the responsibility or nonresponsibility of a prospective offeror.

If the Contracting Officer requires additional information, the prospective offeror shall promptly supply such information within two (2) working days from the date requested. Failure to supply the requested information within the above stated time may be considered unreasonable and may be grounds for a determination of nonresponsibility.

Notwithstanding the paragraph immediately above, the Contracting Officer shall not be precluded from requesting additional information.

Upon determination that a prospective offeror is not fully qualified to perform the work, the shall afford the prospective offeror an opportunity to be heard. Upon conclusion of the hearing and if still of the opinion that the offeror is not fully qualified to perform the work, the Contracting Officer shall refuse to receive or consider any offer offered by the prospective offeror.

A written determination of nonresponsibility of an offeror shall be made by the Contracting Officer. The prospective offeror shall be immediately notified of the determination. The decision of the Contracting Officer shall be final unless the offeror applies for administrative review pursuant to Chapter 126, Subtitle 11, Title 3, HAR. (Auth: HRS: 103D-310) (Imp: HRS 103D-310) (Auth: 3-122-108, HAR)

2.5 OFFER FORM

Offers must be on an offer form provided for such purpose by the Department. Offers must be signed in ink by the person or persons duly authorized to sign offers in the space provided for signature on the offer forms. In the case of a domestic corporation, the title or titles of the person or persons signing must be stated. Where the offeror is an association or group, the title or titles of the person or persons signing must be stated and an affidavit of the association or group must be attached which acknowledges the authority of the signer or signers to sign offers and all other necessary documents in connection therewith for the association or group.

Offers shall be sealed and enclosed in envelopes showing the name of the project. Unless otherwise specified, offerors shall submit offers on all items shown on the offer form. Offers shall be typewritten or printed in ink. Errors may be erased or crossed out, and corrections typewritten or printed in ink must be initialed in ink by the persons or persons signing the bids.

The offers shall be deposited at the Department, not later than the time specified for such opening. Offers received after the specified time for opening in the notice, as evidenced by the time stamp of the Department, shall be considered late and rejected; however, a late offer shall not be considered late if received before contract award and would have been timely but for the action or inaction of personnel within the Department. A late offer that will not be considered for award shall be returned to the offeror unopened as soon as practicable and accompanied by a letter from the Contracting Officer stating the reason for its return. (Auth: 3-122-16.08(a)(b) HAR)

Offers transmitted via facsimile are unacceptable and will be rejected and returned to the offeror.

2.6 OFFER FORM, INTERPRETATION OF

The offer form does not necessarily outline all of the work involved in the performance of the contract, but is merely a list of items upon which the computation of compensation is to be based. The offer form contains all items to be used in such computation, and the compensation computed therefrom shall be full compensation for the performance of the contract.

If it should appear to a prospective offeror that the performance of the work under the contract or any of the matters relative thereto, is not sufficiently described or explained in the offer form, or that any discrepancy exists between different parts thereof, or that the full intent of the form is not clear, then the offeror shall submit a written request for clarification to the Contracting Officer no later than ten (10) calendar days before the day fixed for the opening of offers, as evidenced by the time-stamp of the Department. The offeror submitting the inquiry shall be responsible for its delivery.

If additional information is deemed necessary, such information will be issued in an

addendum by the Contracting Officer. The addendum will be mailed, facsimile, or delivered to all persons who have obtained the special provisions, plans, and specifications of the contract. All addenda issued shall be a part of the contract. (Auth: 3-122-16.06 HAR)

If during discussions during the RFP process, there is a need for any substantial clarification or change in the RFP, the RFP shall be amended by an addendum to incorporate the clarification or change. Addenda to the RFP shall be distributed only to priority-listed Offerors and shall be a part of the contract.

No oral interpretation, instruction or information concerning the contract given by any officer, employee or agent of the Department shall be binding on the Department. (HAR 3-122-16.06)

2.7 PRICES TO COVER ENTIRE CONTRACT

Offerors shall include in their offered prices the entire cost of the performance of the contract, and it is understood and agreed that there is included in each lump sum or unit price, the entire cost of all items incidental to the performance of the contract, covered by such lump sum or unit price offer. Offerors in figuring the offer price shall take into consideration the cost of all freight and delivery charges, marine insurance and taxes; and shall include the cost of furnishing and installing all equipment as called for in the specifications including warranty repairs of the complete unit. Whenever installation is specified, installation shall include all necessary labor, materials and other incidentals required to make a complete operative unit. When an offeror is in doubt as to the proper item to which the anticipated cost of any incidental item is to be allocated, he or she shall include such cost in the lump sum or unit price for the items that he or she deems most appropriate.

It is understood and agreed that whenever unit price(s) is/are called for on the provided page(s), all offerors must indicate their unit price(s) on the blank space(s) provided thereon. Failure to comply will be grounds for rejection. (Auth: 3-122-97 HAR).

Prices shall remain valid for ninety (90) calendar days after the established bid submission deadline.

2.8 COST AND PRICING DATA- PROPOSALS/Sole Source

a) A contractor, except as provided in subsection c herein, shall submit cost or pricing data and shall certify that, to the best of the contractor's knowledge and belief, the cost or pricing data submitted is accurate, complete and current as of a mutually determined specified date prior to the date of:

1) The pricing of any contract awarded by competitive sealed proposals or pursuant to the sole source procurement authority, where the total contract amount is expected to exceed an amount established in HAR; or

b) If this provision is applicable then the price to the Department, including profit or fee, shall be adjusted to exclude any significant sums by which the Department finds that the

price was increased because the contractor furnished cost or pricing data that was inaccurate, incomplete, or not current as of the date agreed upon between the parties.

c) This section shall not apply to contracts where:

- 1) The contract price is based on adequate price competition
- 2) The contract price is based on established catalog prices or market prices;
- 3) The contract prices are set by law or rule;
- 4) It is determined in writing that the requirements of this section may be waived.
(HRS 103D-312)

2.9 BID SECURITY

Bid security shall be required for construction contracts procured by way of invitation for bid or request for proposals, of \$25,000 or more or for construction contracts for less than \$25,000 when required by the Contracting Officer. Bid security shall be in an amount equal to at least five percent (5%) of the amount of the base bid and additive alternates or in an amount required by the terms of the federal funding.

Acceptable bid security, shall be limited to:

1. Surety bond underwritten by a company licensed to issue bonds in the State of Hawai‘i;
2. Legal tender of the United States of America; or
3. A certificate of deposit; share certificate; or cashier’s, treasurer’s, teller’s, or official check drawn by, or a certified check accepted by a bank, savings institution, or credit union insured by the United States Federal Deposit Insurance Corporation or the National Credit Union Administration and payable at sight or unconditionally assigned to the Department.
 - a. These instruments may be utilized only to a maximum of \$100,000.
 - b. If the required security or bond amount totals over \$100,000, more than one instrument not exceeding \$100,000 each and issued by different financial institutions which meet the requirements of this subsection shall be accepted. (HAR 3-122-222)

All documentation provided to the Department agency shall contain the original signatures signed in ink. (HAR 2-122-222, 3-122-223). Unless it is determined that a failure to provide bid security is non-substantial, all bids required to be accompanied by bid security that fail to have the appropriate bid security shall be rejected. Bid deposit form is attached hereto as Exhibit A. (Auth. 3-122-222; 3-122-223 HAR).

2.10 PUBLIC OPENING OF BIDS

Bids shall be opened and read publicly, at the time and place indicated in the Notice to Bidders. Bidders or their authorized agents may be present.

Bidders may request for nondisclosure of trade secrets and other proprietary data in writing. Confidential material shall be readily separable from the bid in order to facilitate public inspection of the nonconfidential portion of the bid: The Contracting Officer shall determine the validity of the request for nondisclosure. (Auth: 3-122-30, HAR)

2.11 RECEIPT AND REGISTRATION OF PROPOSALS

Proposals and modifications shall be time-stamped upon receipt and held in a secure place by the procurement officer until the established due date. Proposals and modifications shall not be opened publicly, but shall be opened in the presence of two (2) or more County officials. Proposals and modifications shall be shown only to members of the evaluation committee and Department personnel or their designees having legitimate interest in them. (Auth: 3-122-51, HAR).

2.12 EXAMINATION OF PLANS, SPECIFICATIONS, SPECIAL PROVISIONS AND SITE

Offerors shall examine the site of the proposed work and the provisions of the contract, including but not limited to the proposal, addenda, bond forms, bid form, special provisions, plans and specifications before submitting a bid or proposal. The submission of a bid or proposal shall be considered conclusive evidence that the offeror has made such examination; knows the surface and subsurface conditions of the site, the character, quality and quantities of labor, materials and equipment and other requirements necessary under the contract; and agrees to all and every item, covenant, condition and provision of the contract.

Where investigation of subsurface conditions has been made by the Department, in respect to foundation or other design, offerors may inspect the records of the Department as to such investigation and examine any sample that may be available.

Investigations of subsurface conditions are made for the purpose of design, and the Department assumes no responsibility whatsoever as to the sufficiency or accuracy of borings or of the log of test borings or reports or other investigations, or of the interpretation thereof, and there is no guaranty, either expressed or implied, that the conditions indicated are representative of those to be encountered during the performance of the contract, or any part thereof, or that the bidder or proposer may not encounter unforeseen subsurface conditions.

Making information concerning subsurface conditions available to bidders or proposers is not to be construed in any way as a waiver of the provisions of the first paragraph of this subsection and bidders or proposers must satisfy themselves through their own investigation as to conditions to be encountered.

Records of such investigations as may have been made by the Department may be inspected at the Department of Water.

2.13 TRADE NAMES AND ALTERNATIVES

Before Bid or Proposal Opening. When the plans or specifications specify one (1) or more manufacturers' brand names or makes of materials, devices or equipment or system indicating a quality style, appearance or performance, such specifications shall be deemed to be used for the purpose of establishing a standard of quality and to facilitate the description of the material or process desired and shall be deemed to be followed by the words "or equal". The offeror shall base his or her offer on either one of the specified brands or an alternate brand which the Contracting Officer has approved to be equal or better by way of addendum to such specification and/or plans. If an offeror intends to base his or her offer on an alternate brand, unless otherwise specified, he or she shall submit a written request to do so, to the Contracting Officer at the earliest date possible, but no later than ten (10) calendar days as evidenced by the time-stamp of the Department, before the day fixed for the opening of offers.

The burden of proof as to the comparative quality and suitability of alternative equipment, articles or materials shall be upon the offeror and he or she shall furnish, at his or her own expense, such information relating thereto as may be required by the Contracting Officer. The Offeror shall issue a statement of variances that lists all features of the proposed substitution which differ from the plans, specifications and/or product(s) specified and must certify that the substitution has no other variant features. Should an unlisted variance be discovered after installation of the product, the remedy shall be immediate replacement with a specified product at no cost to the Department. The Contracting Officer shall be the sole judge as to the comparative quality and suitability of alternative equipment; articles or materials and his or her decisions shall be final.

Any offeror, who bases his or her offer on an alternate brand which has been approved by the Contracting Officer, shall include in his or her offer the additional cost required for all modifications in the contract and the cost of all additional diagrams and drawings required to accommodate the alternate equipment. The modifications referred to include the changes in design that may be required for such work as, but not limited to, electrical, plumbing and other waterworks facilities.

2.14 PREFERENCES

- A. All offers shall comply with the preferences, as applicable, outlined in HAR 3-124, including but not limited to Hawai'i Products Preference and Recycled Products Preference, and the Apprenticeship Program Preference laid out in Section 103-55.6, Hawai'i Revised Statutes, as enacted by S.B. 19, Act 17, SLH 2009, and the State of Hawai'i Comptroller's Memorandum 2011-25 as amended, which provides for a Hawai'i Apprenticeship Preference for public works construction projects with estimated values of \$250,000 or greater.
- B. This subsection shall not apply whenever its application will disqualify the Department from receiving Federal funds or aid.

2.15 MODIFICATION OR WITHDRAWAL OF OFFERS

- A. **Pre-opening Modification or Withdrawal of Offers.**

Offers may be modified or withdrawn at any time prior to the time fixed in the notice to offerors for opening of offers, or if applicable, prior to the date at which the Best and Final Offer is due.

An offeror may withdraw his or her offer by: (1) a written notice received by the Department, or (2) a notice sent by facsimile machine to the Department.

A offeror may modify his or her offer by: (1) a written notice accompanying the actual modification received by the Department, stating that a modification to the offer is submitted, or (2) a written notice accompanying the actual modification by facsimile to the Department, provided the offeror submits the actual written notice and modification within two (2) working days of receipt of the facsimile. (Auth: 3-122-16.07, HAR)

B. Late Offers, Late Withdrawals and Late Modifications.

Any notice of withdrawal or notice of modification of any offer with the actual modification received by the Department after the time and date set for receipt and opening is late and shall not be considered for award except when received before contract award and would have been timely but for the action or inaction of personnel within the Department. (Auth: 3-122-16.08, HAR)

- C. After the established due date for offers, an offer may be withdrawn only if the Department fails to award the contract within ninety (90) calendar days after the established due date for offers.

2.16 LISTING OF JOINT CONTRACTORS AND SUBCONTRACTORS

Pursuant to Section 103D-302, HRS, as amended, all offerors shall state in their bids the name of each person or firm that will be engaged as a joint venture, partner, or subcontractor and the nature and scope of the work to be performed by each such joint venture, partner, or subcontractor. All bids which do not comply with this requirement shall be rejected pursuant to Sec. 103D-302(b), H.R.S.

MANDATORY LICENSING REQUIREMENT:

“A” general engineering contractors and “B” general building contractors are reminded that due to the Hawai‘i Supreme Court’s January 28, 2002 decision in Okada Trucking Co., Ltd. v. Board of Water Supply, et al., 97 Haw. 450 (2002), they are prohibited from undertaking any work, solely or as part of a larger project, which would require the general contractor to act as a specialty contractor in any area in which the general contractor has no license. Although the “A” and “B” contractor may still bid on and act as the “prime” contractor on an “A” or “B” project (See, HRS § 444-7 for the definitions of an “A” or “B” project.), respectively, the “A” and “B” contractor may only perform work in the areas in which they have the appropriate contractor’s license (An “A” or “B” contractor obtains “C” specialty contractor’s license either on its own, or automatically under HAR § 16-77-32.). The remaining work must be subcontracted out to appropriately licensed entities. **It is the sole responsibility of the contractor to review the requirements of this project and determine the appropriate licenses that are required to complete the project.**

Although the bid documents may provide a list of the contractor licenses that the County anticipates are required to complete this particular project, this list is not all inclusive and additional licenses may be required. If a specialty license/class is required to complete the scope of work and the contractor does not list said license(s), the contractor may have their bid rejected as non-responsive. Examples of specialty license/classes that should be listed are licensed surveyor, licensed geotechnical engineer, licensed structural engineer, licensed civil engineer, specialty inspectors, archaeologist, and cultural monitor.

The contractor shall be responsible under the contract for acts and omissions of his or her subcontractors, suppliers and persons either directly or indirectly employed by them, as fully as he or she is for acts and omissions of his or her own employees. Nothing in the contract shall create any contractual relation between any subcontractor, partner, joint venture or supplier and the Department or any obligation on the part of the Department to pay or cause to be paid any money to any subcontractor or supplier.

2.17 BIDS, DISQUALIFICATION OF

A. Bids which are conditional or not in compliance with the bidding instructions may be rejected.

Multiple or alternate offers. Unless specifically provided for in the solicitation, multiple or alternate offers shall not be accepted and all such offers shall be rejected (HAR 3-122-4)

B. Bids may be rejected for the following reasons including, but not limited to:

1. Bidder determined to be “nonresponsive,” pursuant to Subchapter 13, HAR. (Auth: 3-122-97, HAR); or
2. The bid is “not responsive”. Bid does not conform in all material respects to the invitation for bids by reason of its failure to meet the requirements of the specifications or permissible alternates or other acceptability criteria set forth in the invitation for bid pursuant to section 3-122-33 HAR. (Auth: 3-122-97, HAR); or
3. The good, service, or construction item offered in the bid is unacceptable because of its failure to meet the requirements of the specifications or permissible alternatives or other acceptability criteria set forth in the invitation for bids under the provisions of Sec. 3-122-33, HAR. (Auth: 3-122-97, HAR)
4. Bid submitted by any person submitting more than one (1) bid under the same or different names, under his or her own name, or through his or her agents, or through joint ventures, partnerships or corporations in which he has more than twenty-five percent (25%) interest in each of them, or through any contractor thereof.

If there is any evidence indicating that two (2) or more bidders are in collusion to restrict competitive bidding, the bids of all such bidders shall be

rejected and such evidence may be a cause for the disqualification of the participants in any future proposal involving any contract with the Department.

5. Any offer which is conditioned upon receiving award of both the particular contract being solicited and another Department contract. (Auth: 3-122-6, HAR)

2.18 PROPOSAL, DISQUALIFICATION OF

- A. A proposal may be accepted with modification or correction unless the solicitation states otherwise.
 1. This allowance must be considered in determining whether reasons exist for rejecting all or any part of a proposal.
 2. A proposal may be rejected for reasons including but not limited to:
 - a. The offeror is nonresponsible pursuant to Subchapter 13, HAR. (Auth.: 3-122-97)
 - b. The proposal, after any opportunity has passed for modification or clarification, fails to meet the announced requirements of the agency in some material respect; or
 - c. The proposed price is clearly unreasonable.

2.19 OFFEROR LIMITED ACCEPTANCE

- A. An offeror may not limit acceptance to the entire bid or proposal offering, unless allowed by the solicitation:
 1. If the acceptance of an offer is so limited by the offeror but not allowed, the offer will be determined to be not acceptable and rejected.
 2. If the acceptance of an offer is so limited by the offeror and allowed, the purchasing agency shall not reject part of the offer and award on the remainder. (3-122-97 HAR)

2.20 MISTAKES IN BIDS

- A. A bidder may correct, waive or withdraw an obvious mistake in his or her bid to the extent it is not contrary to the best interest of the Department or to the fair treatment of other bidders.
- B. Before Bid Opening. A bidder may remedy a mistake in a bid discovered before the time fixed in the notice to bidders for opening of bids by withdrawing or correcting the bid as provided in subsection 2.15 of these General Provisions.

C. After Bid Opening But Prior to Award.

1. A mistake in a bid discovered after bid opening but prior to award may be corrected or waived if:
 - a. The mistake is attributable to an arithmetical error, the Contracting Officer shall so correct the mistake. In case of error in extension of bid price, unit price shall govern.
 - b. The mistake is a minor informality which shall not affect price, quantity, quality, delivery, or contractual conditions, the Contracting Officer may waive such informalities or allow the bidder to request correction by submitting proof of evidentiary value which demonstrates that a mistake was made. The Contracting Officer shall prepare a written approval or denial in response to this request. Examples of such mistakes include:
 - (1) Typographical errors;
 - (2) Failure to return the number of signed bids required by the invitation for bids;
 - (3) Failure to acknowledge receipt of an amendment to the Invitation for Bids, but only if:
 - (a) It is clear from the bid that the bidder received the amendment and intended to be bound by its terms; or
 - (b) The amendment involved had a negligible effect on price, quantity, quality or delivery;
 - (4) Arithmetical errors;
 - (5) Transposition errors;
 - (6) Failure of a bidder to sign the bid, but only if the unsigned bid is accompanied by other material indicating the bidder's intent to be bound.
2. A mistake in a bid discovered after bid opening but prior to award may be withdrawn if the mistake is attributable to an obvious error which shall affect price, quantity, quality, delivery, or contractual conditions, provided:
 - a. The bidder requests withdrawal by submitting proof of evidentiary value which demonstrates that a mistake was made; and
 - b. The Contracting Officer prepares a written approval or denial in response to this request. (Auth: 3-122-31 HAR).

D. After Award.

A mistake in a bid discovered after award is not permissible except when the Manager makes a written determination that it would be unreasonable not to allow the mistake to be remedied. (Auth: 103D-302, HRS, 3-122-31, HAR)

2.21 DISCUSSIONS WITH OFFERORS-REQUEST FOR PROPOSALS

- A. The Department may hold discussions with priority listed offerors in order to promote understanding of the Department's requirements and priority-listed offeror's proposals; and
- B. To facilitate arriving at a contract that will provide the best value to the Department, taking into consideration the evaluation factors set forth in the request for proposals.
- C. Proposals may be accepted on evaluation without discussion.
- D. Any substantial oral clarification of a proposal shall be reduced to writing by the priority-listed offeror;
- E. If during discussions there is a need for any substantial clarification or change in the request for proposals, the request for proposals shall be amended by an addendum to incorporate the clarification or change
- F. Addenda to the request for proposals shall be distributed only to priority-listed offerors.
 - 1. The priority-listed offerors shall be permitted to submit new proposals or to amend those submitted;
 - 2. If in the opinion of the procurement officer or the evaluation committee, a contemplated amendment will significantly change the nature of the procurement, the request for proposals shall be canceled and a new request for proposals issued.

SECTION 3 - AWARD AND EXECUTION OF CONTRACT

3.1 AWARD OF CONTRACT

No contract shall be awarded to any person suspended under, and as provided in, the provisions of Chapters 104 and 444, HRS, as amended and any federal law if federal funds are used in the contract, or to any firm in which such suspended person as an interest.

A. Bids.

Award of contract, if made, shall be made to the lowest responsive, responsible bidder, whose bid meets the requirements and criteria set forth in the invitation for bids. (Auth: 3-122-33, HAR)

B. Proposals.

Award of contract, if made, shall be made to the responsible offeror whose proposal is determined in writing to provide the best value to the Department taking into consideration price and the evaluation criteria in the request for proposals. (Auth: 3-122-57, HAR)

3.2 CANCELLATION OF SOLICITATION OR AWARD

The Contracting Officer reserves the right to reject any and all offers and to waive any defect as, in his or her judgment may be in the best interest of the Department.

The Manager reserves the right to cancel the award of a contract at any time before a contract is executed by the Department and the contractor.

3.3 FUNDS, AVAILABILITY OF

A. Department of Water Funds.

No contract award shall be binding or of any force and effect without an endorsement by the Waterworks Controller certifying that there is an appropriation sufficient to cover the amount of the contract; provided that if the contract is a multi-term contract, the Waterworks Controller shall only be required to certify that there is an appropriation or balance of an appropriation sufficient to cover the amount required to be paid under the contract during the fiscal year or remaining portion of the fiscal year of each term of the multi-year contract.

This section shall not apply to any contract under which the total amount to be paid to the contractor cannot be accurately estimated at the time the contract is to be awarded. (Auth.: 103D-309 HRS).

B. State and/or Federal Funds.

A contract which is supplemented by state and/or federal funds, Section 3.3(A) above shall be applicable only to that portion of the contract price as is payable out of Board funds. As to the portion of the contract price as is expressed in the contract to be payable out of federal funds, the contract shall be construed to be an agreement to pay the portion to the contractor, only out of state and/or federal funds to be received from the state and/or federal government when the state and/or federal

funds are so received by the Board and shall not be construed as a general agreement by the Department to pay said portion out of any funds other than those which are received from the estate and/or federal government. This subsection shall be liberally construed so as not to hinder or impede the County in contracting for any project involving financial aid from the federal government. (3-122-109, HAR)

C. Contracts Utilizing One-Hundred Percent (100%) Federal Funds.

A contract which is funded one-hundred percent (100%) by federal funds shall be construed as an agreement to pay the contract price only out of federal funds to be received by the Department from the federal government when the federal funds are so received by the Department and shall not be construed as a general agreement to pay such amount at all events out of any funds other than those which are received from the federal government. (HRS 103D-309(b))

3.4 ENTERING INTO CONTRACT

Upon award of the contract to an offeror, such offeror shall enter into the contract by signing the contract and by furnishing bonds for faithful performance and payment as prescribed in the invitation for bid or proposal, copies of certificates of insurance and endorsements demonstrating compliance with the insurance policies required to be procured by the contractor and subcontractor and tax clearances prescribed in subsection 3.5 within fifteen (15) calendar days after the date the contract has been mailed to the contractor or within such further time as the Manager may allow after the offeror has received the contract for execution.

If the offeror to whom the contract is awarded fails or neglects to enter into the contract and furnish bonds, as prescribed in subsection 3.6, and the copies of certificates of insurance as required by contract, the bid security which accompanied the offer pursuant to subsection 2.9 shall be forfeited or in the case where such bid security was in the form of a surety bond, the proceeds representing the bid security shall be collected under the surety bond and the amount so forfeited or collected shall be paid to the Department. Upon such failure or neglect, the Contracting Officer may award the contract to the next lowest responsible bidder or the next responsible proposer whose proposal is determined to provide the best value to the Department, or publish another call for bids or proposals as, in his or her judgment, may be in the best interests of the Department.

3.5 RESPONSIBILITY OF OFFERORS AND TAX CLEARANCE

Upon award of the contract, HRS 103D-310 specifies that all Offerors shall comply with all laws governing entities doing business in the State, including, but not limited to HRS Chapters 237, 383, 386, 392, and 393.

In addition, pursuant to HRS 103D-328 and HRS 103-53, no contract shall be binding or effective until the purchasing agency confirms tax clearance from the director of taxation and the Internal Revenue Service. The Offeror shall provide updated tax clearances as required by the Director of Finance to comply with HRS Section 103-53, as amended.

The offeror, as proof of compliance with the requirements of section 103D-310(c), HRS, upon award of a contract shall submit, with the contract signed by the offeror, to the

Department verification using Hawai'i Compliance Express for the following requirements:

- A. A tax clearance from the director of taxation and the Internal Revenue Service, current within six (6) months of issuance date, to the effect that all tax returns due have been filed, and all taxes, interest, penalties levied or accrued under the provisions of Title 14 that are administered by the Department of Taxation and under the Internal Revenue Code against the contractor have been paid; and
- B. A certificate of compliance for chapters 383 (Hawai'i Employment Security Law), 386 (Worker's Compensation Law), 392 (Temporary Disability Insurance Law), and 393 (Prepaid Healthcare Act), HRS from the department of labor and industrial relations, current within six months of issuance date; and
- C. A certificate of good standing from the business registration division of the department of commerce and consumer affairs, current within six months of issuance date.

The offeror shall provide updated tax clearances as required by the Contracting Officer to comply with Section 103-53, HRS, as amended.

3.6 PERFORMANCE AND PAYMENT BONDS

- A. Performance and payment bonds shall be required for construction contracts procured through the IFB or RFP process:
 - 1. When the contract price is \$25,000 or more (Act 173, SLH 2012); and
 - 2. When the contract price is less than \$25,000 and is required by the Manager.
 - 3. Federally funded contracts wherein the conditions of the funding requires a performance or payment bond or both.
- B. Performance and payment bonds shall be required for construction contracts procured through the Small Purchase Method (HRS 103D-305):
 - 1. When the contract price is \$50,000.00 or over.
- C. The amount of the performance and payment bonds, when required, shall be in an amount equal to one-hundred percent (100%) of the contract price.
- D. Performance and payment bonds, shall be delivered by the contractor to the Department when the contract is executed. If the contractor fails to deliver the required performance and payment bonds, the contractor's award shall be canceled, the contractor shall be subject to a claim by the Board for all resulting damages its bid security enforced, and award of the contract shall be made to the next lowest offeror pursuant to Subchapter 11, HAR. (Auth: 3-122-224, HAR)

Acceptable forms of performance and payment bonds. Acceptable performance and payment bonds shall be limited to:

1. Surety bond underwritten by a company licensed to issue bonds in the State of Hawai'i;
 2. Legal tender of the United States of America; or
 3. A certificate of deposit; share certificate; or cashier's, treasurer's, teller's, or official check drawn by, or a certified check accepted by a bank, savings institution, or credit union insured by the United States Federal Deposit Insurance Corporation or the National Credit Union Administration and payable at sight or unconditionally assigned to the Department.
 - a. These instruments may be utilized only to a maximum of \$100,000.
 - b. If the required security or bond amount totals over \$100,000, more than one instrument not exceeding \$100,000 each and issued by different financial institutions which meet the requirements of this subsection shall be accepted. (Auth: 3-122-222, HAR)
- E. The Department shall not pay interest on any security provided.
- F. All alterations, extensions of time, extra and additional work and other changes authorized in the specifications or in any part of the contract may be made without securing the consent of the surety or sureties on the performance and payment bonds.
- G. Surety shall be subject to the approval of the Contracting Officer and shall be required to justify, as prescribed by law, provided that the Contracting Officer in his or her discretion may require each surety to justify in the prescribed amount at any time. If the surety is found to be insufficient, the contractor shall furnish a new bond with sufficient surety within ten (10) calendar days after the day it is notified of the insufficiency or within such further time as the Manager may allow in writing.
- H. Performance and payment bond forms are attached hereto as Exhibits.
- I. Every person who has furnished labor or material to the Contractor for the work provided in the contract for which a payment bond or a performance and payment bond is furnished under this section, and who has not been paid amounts due before the expiration of a period of ninety days after the day on which the last of the labor was performed or material was furnished or supplied, for which a claim is made, may institute an action for the amount, or balance thereof, unpaid at the time of the institution of the action against the Contractor or Contractor and its sureties, on the payment bond and have their rights and claims adjudicated in the action, and judgment rendered thereon; subject to the City's priority on the bond. As a condition precedent to any such suit, written notice shall be given by registered or certified mail to Contractor and surety, within ninety days from the date on which the person did or performed the last labor or furnished or supplied the last of the material for which claim is made, stating with substantial accuracy the amount claimed and the name of the party to whom the material was furnished or supplied or for whom the

labor was done or performed.

- J. Every suit instituted upon a payment bond shall be brought in the circuit court of the circuit in which the project is located, but no suit shall be commenced after the expiration of one year after the day on which the last of the labor was performed or material was supplied for the work provided in the contract. The obligee named in the bond need not be joined as a party in any suit.
- K. If the full amount of the liability of the Contractor or the Contractor and its sureties on the security is insufficient to pay the full amount of the claims, then, after paying the full amount due the City, the remainder shall be distributed pro rata among the claimants. [HAR 3-122-227]
- L. Certified copies of bonds may be requested and obtained by any person upon payment of the costs of reproduction and certification of the bonds, and postage. A certified copy of a bond shall be prima facie evidence of the contents, execution, and delivery of the original. [HAR 3-122-228]
- M. Contracts with Federal funds. In addition to the requirements of this section, whenever a contract is partially or fully funded with Federal funds, the surety companies shall be those listed in the latest issue of the U. S. Treasury Circular 570.

3.7 CAMPAIGN CONTRIBUTIONS BY STATE AND COUNTY CONTRACTORS

If awarded a contract in response to this solicitation, offeror agrees to comply with HRS §11-355, which states that campaign contributions are prohibited from a State and county government contractor during the term of the contract if the contractor is paid with funds appropriated by the legislative body between the execution of the contract through the completion of the contract. Questions regarding this statute should be directed to State of Hawai‘i Campaign Spending Commission.

3.8 EMPLOYMENT OF STATE RESIDENTS ON CONSTRUCTION PROCUREMENT CONTRACTS

Bidders are advised of the applicability of Act 68, SB 2840, HRS Section 103B, Employment of State Residents on Construction Procurement Contracts, (2010) (“Act 68”). Act 68 requires the awarded contractor to ensure that Hawai‘i Residents (as defined in the Act) compose not less than eighty percent of the workforce employed to perform the contract. This requirement shall also apply to subcontracts of \$50,000 or more in connection with any construction contract procured under HRS Chapter 103D, HRS § 103D-305 (small purchases), or if there is a conflict with any federal law as further detailed herein under “Conflict with Federal Law.” See Exhibit O.

3.9 HAWAII PROCUREMENT LAW

If any provision in this General Provisions is in conflict with any provision in the Hawai‘i Administrative Rules, Chapter 103D and 103, HRS, the provisions of the Hawai‘i Administrative Rules, Chapter 103D and 103, HRS shall control and supersede the provisions in this General Provisions.

SECTION 4 - LEGAL RELATIONS AND RESPONSIBILITY

4.1 AUTHORITY OF THE CONTRACTING OFFICER

The Contracting Officer shall decide all questions which may arise relating to the quality and acceptability of the materials furnished and work performed, the manner of performance and rate of progress of the work, the interpretation of the plans and specifications, the acceptable fulfillment of the contract on the part of the Contractor, the compensation under the contract and the mutual rights of the parties to the contract.

The Contracting Officer shall have the authority to enforce and make effective such decisions and orders which the Contractor fails to carry out promptly and diligently.

The Contracting Officer shall have the authority to suspend the work wholly or in part due to the failure of the Contractor to correct conditions unsafe for the workers or the general public; for failure to carry out provisions of the contract; for failure to carry out orders; for such periods as he may deem necessary due to unsuitable weather; for conditions considered unsuitable for the prosecution of the work or for any other condition or reason deemed to be in the public interest.

4.2 INDEPENDENT CONTRACTOR

- A. The contractor shall perform the contract as an independent contractor and shall defend, indemnify and hold harmless the Department, Board, its officer, agents, and employees from and against all claims, damages, losses, liability, and expenses, including but not limited to attorney's fees, court costs, or other alternative dispute resolution costs arising out of, resulting from, or otherwise but for the performance or furnishing of work or services under the contract for any injury, death or damages to persons or property arising out of the performance of the contract; but only to the extent caused in whole or in part by the actual or alleged acts, errors, or omissions of the Contractor, Contractor's subcontractor(s), or anyone directly or indirectly employed or hired by the Contractor or anyone for whose acts Contractor may be liable.
- B. The obligations of the contractor under Subparagraph A above shall not extend to the liability of the Department, Board, and its officers and employees because of negligence in (1) the preparation of maps, plans, drawings, land surveys, designs or specifications, or (2) the giving of directions or instructions with respect to the requirements of the contract by written order; provided that such giving of directions or instructions is the primary cause of the injury or damage.
- C. The contractor shall defend, indemnify and save the Department, Board, its officers, agents, and employees harmless from any and all claims for infringement by reason of the use of any patented design, device, process or material, in connection with work to be performed under the contract.

All royalties due or becoming due for the use of any patented design, devices, process or material used in connection with the work performed under the contract shall be paid by the contractor, and shall be held to be included in the contract price.

- D. The contractor shall agree to defend, indemnify and save harmless the Department against any and all deaths, injuries, losses and damages to persons or property, and any and all claims, demands, costs, liabilities, suits, judgments, actions or proceedings of every name, character and description which may be suffered or incurred by or brought against the Department to the extent arising from contractor's negligent performance of his or her duties and responsibilities pursuant to this contract except where said liability, loss or damage results solely from the negligence or misconduct of Department, Board, its employees or representatives.

4.3 LAWS, REGULATIONS

The contractor shall at all times keep himself fully informed, of all future and present Federal, State, County, and Department laws, ordinances, policies, rules and regulations which affect the contract and the performance thereof, including but not limited to:

- A. Chapter 103, HRS, relating to expenditure of Public Money and Public Contracts.
- B. Chapter 103D, HRS, relating to the Hawai'i Public Procurement Code.
- C. Chapter 104, HRS, relating to Wages and Hours of Employees on Public Works.
- D. Chapter 321, HRS, relating to Health Department.
- E. Chapter 377, HRS, relating to Hawai'i Employment Relations Act.
- F. Chapter 378, HRS, relating to Employment Practices.
- G. Chapter 383, HRS, relating to Hawai'i Employment Security Law.
- H. Chapter 386, HRS, relating to Worker's Compensation Law.
- I. Chapter 387, HRS, relating to Wage and Hour Law.
- J. Chapter 388, HRS, relating to Payment of Wages and Other Compensation.
- K. Chapter 390, HRS, relating to Child Labor Law.
- L. Chapter 396, HRS, relating to Occupational Safety and Health.
- M. Chapter 444, HRS, as amended, relating to licensing of contractors.

The contractor shall comply with all such present and future laws, regulations, and ordinances, including the giving of all notices necessary and incident to the performance of the contract. If any discrepancy or inconsistency is discovered between the contract and any such law, regulation or ordinance, the contractor shall forthwith report the same in writing to the Contracting Officer.

4.4 PERMITS, LICENSES

The contractor shall obtain all permits, licenses and approvals required by the Department, County, State, or Federal Government, for the execution of the contract, and pay all charges and fees therefore including, but not limited to overtime inspection, cost of preparation of documents, and any and all other costs associated with attaining required permit approvals.

4.5 NO PERSONAL LIABILITY

Neither the Contracting Officer nor the Board nor any other officer or employee of the Department, in the performance of their duties, shall incur personal liability to the contractor for any action taken in good faith.

4.6 COORDINATION OF SPECIAL PROVISIONS, PLANS, SPECIFICATIONS, GENERAL PROVISIONS, WATER STANDARDS, AND OTHER PARTS OF THE CONTRACT DOCUMENTS

The special provisions, plans, specifications, general provisions, Water Standards, contract documents and all supplemental documents are essential parts of the contract, and a requirement occurring in one is as binding as though occurring in all. They are intended to be complementary and to describe and provide for the complete work. In case of conflict or discrepancy within any part of the contract, the stricter requirements, including Hawai'i State Statutory requirements, shall govern. Unless it is apparent that a different order of precedence is intended, the following is the precedence list with 1 taking precedence over two, two taking precedence over three, etc.:

1. Special Provisions
2. Plans
3. Specifications/Request for Proposals
4. Agreement Documents
5. General Provisions
6. Water Standards
7. Other Agency Standards

Instructions to offerors, addendas and the pre-bid or pre-proposal meeting minutes are hereby incorporated by reference and made a part of the Special Provisions.

Hawaii Standard Specifications for Road, Bridge and Public Works Construction, 2005.

Unless otherwise specified, the means and methods of Hawai'i Standard Specifications for Road, Bridge and Public Works Construction, 2005, as amended, shall govern the requirements for construction within all State and County roadway rights-of-way.

SECTION 5 - SCOPE OF CONTRACT

5.1 SCOPE OF CONTRACT

The scope of the contract encompasses the contractor's furnishing of, and payment for, all labor, supervision, skills, materials, tools, transportation, equipment and apparatus, and all incidentals necessary to perform all the work and do all the things necessary in accordance with the provisions of the contract documents by the contractor. See Sample Contract attached hereto as Exhibit J.

5.2 REQUESTS FOR INFORMATION

A. **Request for Information (RFI)** - An RFI is a written request, using attached Form Exhibit P from the contractor to the Contracting Officer, seeking an interpretation or a clarification of some requirement of the contract documents. The contractor shall clearly and concisely set forth the issue for which they seek clarification or interpretation and why a response is needed from the Department. The Contractor shall, in the RFI, set forth their interpretation or understanding of the requirement including reasons why they have reached such an understanding. Responses from the Department will not change any requirement of the contract documents unless so noted in the RFI Response by the Department.

1. The following is a non-exhaustive list of what shall NOT be accepted as an RFI:
 - a. Submittals for clearly identifiable items that should have been addressed pre-bid.
 - b. Numerous and excessive RFIs that are meant to overwhelm the Department.
 - c. Proposal for alternative construction methods or substitute items.
 - d. RFIs that are meant to address construction means and methods or site safety.
2. RFIs can only be submitted by the Contractor. Submittals by subcontractors shall be rejected outright.
3. Each RFI shall be limited to a single subject of inquiry.
4. All RFIs shall be accompanied by a lowest-cost suggested solution from the Contractor.
5. All RFIs shall include the necessary attachments and exact references. When applicable, references to design drawing numbers and specification sections and a graphic depiction of the resolution shall accompany the RFI.

6. RFIs that fail to conform to these requirements will be rejected at no fault to the Department.

B. **Response to RFI**

Response to an RFI shall be issued within ten (10) working days of receipt of the request from the contractor unless the Contracting Officer determines that a longer period of time is necessary to provide an adequate response. If a longer period of time is determined necessary by the Contracting Officer, the Contracting Officer will, within ten (10) working days of receipt of the RFI, notify the contractor of the anticipated response time.

1. The ten (10) working days referred to herein will start on the date stamped “Received” by the Department and ends on the date stamped “Sent” by the Department.
2. If the contractor submits a RFI on a schedule activity within ten (10) working days or less of float on a current project schedule, the contractor shall not be entitled to any time extension due to the time it takes the Department to respond to the request provided that the owner responds within ten (10) working days set forth above.
3. Responses to RFIs that require revisions to drawings and specifications should be incorporated into the design drawings concurrent with the processing of the RFI.

- C. Responses from the Department will not change any requirement of the contract documents unless so noted by the Department in the response to the RFI. In the event the Contractor believes that a response to a RFI will cause a change to the requirements of the contract document, the contractor shall provide written notice to the owner in accordance with the requirements of Section 5.3 of this Document. Failure to provide such written notice shall waive the contractor’s right to seek additional time or cost as laid out in Section 5.3 of this Document.

5.3 MODIFICATIONS TO THE WORK

A. **Oral Directive.**

Any directive, direction, instruction, interpretation or determination through oral order, or email (“oral directive”) from the Contracting Officer, which, in the opinion of the contractor, causes any change, can be considered as a change only if the contractor gives the Contracting Officer written notice of its intent to treat the oral directive as a change directive. The written notice must be delivered to the Contracting Officer before the contractor acts in conformity with the oral order, direction, instruction, interpretation or determination, but not more than five days after delivery of the oral order to the contractor. The written notice shall state the date, circumstances, whether a time extension will be requested, and source of the order that the contractor regards as a change. The written notice may not be waived and shall be a condition precedent to the filing of a claim by the contractor. Unless the contractor acts in accordance with this procedure, any oral directive shall not be treated as a change and the contractor waives any claim for an increase in the

contract time or contract price related to the work.

B. **Change Order.**

The Contracting Officer, at any time, and without notice to any surety, in a signed writing designated or indicated to be a change order, may unilaterally make changes in the work within the scope of the contract as may be found to be necessary or desirable and may unilaterally make changes in the time of performance of the contract that does not alter the scope of the contract work. Such changes shall not invalidate the contract or release the sureties, and the contractor will perform the work as changed, as though it had been part of the original contract. Minor changes in the work may be directed by the Contracting Officer at no change in contract price or time. Change Order form is attached hereto as Exhibit K.

1. Adjustment of price or time for performance. If any change order increases or decreases the contractor's cost of, or the time required for, performance of any part of the work under this contract, whether or not changed by the order, an adjustment shall be made and the contract modified in writing accordingly. Any adjustment in contract price made pursuant to this clause shall be determined in accordance with the price adjustment clause of this contract or as negotiated.
2. Failure of the parties to agree to an adjustment shall not excuse a contractor from proceeding with the contract as changed, provided that the Contracting Officer, within fourteen (14) calendar days after the changed work commences, makes such provisional adjustments in time for the direct costs of the work as the Contracting Officer deems reasonable.
3. Quotations for modification of work shall be submitted expeditiously and in any case no later than ten (10) working days after receipt of the Department of Water's request. All quotations shall be accompanied by a detailed written statement setting forth all charges the Contractor proposes for the change, properly itemized, and supported by sufficient substantiating data to permit evaluation of charges. All quotations shall be accompanied by a statement as to the proposed change's effect on the project's completion date. If no condition is stipulated, the Department of Water will assume that the acceptance of the quotation will have no adverse effect on the project's completion date.
4. The Contracting Officer has up to twenty (20) days to make a final decision as to whether to accept the entire cost proposal or any discrete cost item contained within the cost proposal or the proposed adjustment to contract time by a contract change order.
5. The right of the contractor to dispute the contract price or time or both shall not be waived by the contractor performing the work, provided however, that the contractor follows the notice requirements for disputes and claims established by the contract or these provisions. Contract Modification Form is attached hereto as Exhibit L.

6. Time period for claim. Within thirty (30) calendar days after receipt of a written change order under subsection, unless such period is extended by the Contracting Officer in writing, the contractor shall file notice of intent to assert a claim for an adjustment. The requirement for timely written notice cannot be waived and shall be a condition precedent to the assertion of a claim.
7. Claim barred after final payment. No claim by the contractor for an adjustment hereunder shall be allowed if notice is not given prior to final payment under this contract.
8. No payment shall be allowed to the Contractor for pricing or negotiating proposed or actual changes. No time extension will be granted for delay caused by late Contractor pricing of changes or proposed changes.
9. Additional performance bond or payment bond may be required by the procurement officer for a contract change order or modification where the contract amount increases. (HAR 3-122-225)
10. Other Claims Not Barred. In the absence of such a change order, nothing in this clause shall restrict the contractor's right to pursue a claim arising under the contract or for breach of contract. (HAR 3-125-4)

5.4 PRICE ADJUSTMENT

- A. Any adjustment in contract price shall be made in one or more of the following ways:
 1. By agreement on a fixed price adjustment before commencement of the pertinent performance or as soon thereafter as reasonably practicable;
 2. By unit prices specified in the contract or subsequently agreed upon;
 3. By the costs attributable to the events or situations under such clauses with adjustment of profit or fee, all as specified in the contract or subsequently agreed upon before commencement of the pertinent performance;
 4. In such other manner as the parties may mutually agree; or
 5. In the absence of agreement between the parties, the provisions of HRS 103D-501(b)(5) shall apply.
- B. Submission of cost or pricing data. The contractor shall be required to submit cost or pricing data if any adjustment in contract price is subject to the provisions of section 103D-312, HRS. The submission of any cost or pricing data shall be made subject to the provisions of subchapter 15, chapter 3-122, HAR. A fully executed change order or other document permitting billing for the adjustment in price under any method listed shall be issued within ten (10) days after agreement on the method

of adjustment.

- C. Determining Adjustments in Price. In determining the adjustment in price to the Department resulting from a change, the allowances for all overhead and extended overhead resulting from adjustments to contract and profit combined, shall not exceed the percentages set forth below per Chapter 3-125, HAR:
1. For the contractor, for any work performed by its own labor forces, twenty percent (20%) of the cost;
 2. For each subcontractor involved, for any work performed by its own forces, twenty percent (20%) of the cost;
 3. For the contractor or any subcontractor, for work performed by their subcontractors, ten percent (10%) of the amount due the performing subcontractor.

Not more than three (3) line item percentages for fee and overhead, not to exceed the maximum percentages shown above, will be allowed regardless of the number of tier subcontractors.

- D. The Department, in determining an adjustment in price using any of the methods listed in 5.4 A (1-4) above may not mandate that the contractor submit its proposal for a price adjustment at a specified percentage that it unilaterally considers to be acceptable.
- E. Paragraphs C. and D., herein, shall not be construed to impair the right of the Contractor and the Department from mutually agreeing to a price adjustment under any method listed in 5.4 A (1-4).

5.5 DIFFERING SITE CONDITIONS

Differing Site Conditions - Contractor's Responsibility. Unless otherwise noted, the contractor accepts the conditions at the construction site as they eventually may be found to exist and warrants and represents that the contract can and will be performed under such conditions, and that all materials, equipment, labor, and other facilities required because of any unforeseen conditions (physical or otherwise) shall be wholly at the contractor's own cost and expense, anything in this contract to the contrary notwithstanding. (H.A.R. 3-125-11)

5.6 ASSIGNMENT, CHANGE OF NAME, NOVATION

- A. **No Assignment.**
No Department contract is transferable, or otherwise assignable, without the written consent of the Manager; provided that a contractor may assign moneys receivable under a contract after due notice to the Department.
- B. **Recognition of a successor in interest; assignment.**
When in the best interest of the Department, a successor in interest may be recognized in an assignment agreement in which the transferor and the transferee

and the Department shall agree that:

1. The transferee assumes all of the transferor's obligations;
2. The transferor remains liable for all obligations under the contract but waives all rights under the contract as against the Department; and
3. The transferor shall continue to furnish, and the transferee, shall also furnish all required bonds.

C. **Change of Name.**

When a contractor requests to change the name in which he or she holds a contract with the Department, the Manager shall, upon receipt of a document indicating such change of name (for example, an amendment to the articles of incorporation of the corporation), enter into an agreement with the requesting contractor to effect such a change of name. The agreement changing the name shall specifically indicate that no other terms and conditions of the contract are thereby changed. (Auth: 3-125-14, HAR)

5.7 VALUE ENGINEERING INCENTIVE

A. **Definitions** as used in this section:

"Net savings" means those savings in project costs realized by the Department as the result of a value engineering change proposal after deducting the contractor's share of the cost savings.

"Single contract" means the single construction for which the cost savings is proposed.

"Value engineering" means an analysis of the requirements for the systems, equipment, and supplies of the single contract for the purpose of achieving a net savings by providing less costly items than those specified without impairing any essential functions and characteristics as service life, reliability, substitutability, economy of operations, ease of maintenance, and necessary standing functions.

"Value engineering change proposal" means a cost reduction proposal based on value engineering submitted by the contractor pursuant to this chapter and particularly identified as such. (HAR §3-132-1)

B. **Applicability.**

1. The provisions of this chapter shall apply to all construction contracts in excess of \$100,000. The application of value engineering incentives to contracts shall not be construed to have an effect on the solicitation or the selection of the contractor.
2. The contractor may develop and submit value engineering change proposals for drawings, designs, specifications, or other requirements of the contract. If any proposal is accepted and approved, in whole or in part, by the

procurement officer, the contract shall be modified and shall include an equitable adjustment of the contract price in accordance with this section.

3. This section shall not apply to any cost reduction proposal that is not identified as a value engineering change proposal by the contractor at the time of its submission to the procurement officer. (HAR §3-132-2)

C. **Section provisions.**

1. The processing of a value engineering change proposal shall be similar to that for any proposed contract change order and shall be considered only after the construction contract is awarded.
2. Nothing herein shall be construed to mean that the Department must accept or approve any or all value engineering change proposals submitted in accordance with this section. The OIC's interpretation and findings relative to the impairment of the functions or characteristics of the item or items covered by the value engineering change proposal shall be final.
3. Adjustment in contract prices and allowances for implementation costs shall be in accordance with this section and shall only be considered if and when the value engineering change proposal is approved by the contract officer. The receipt of the value engineering change proposal by the Department or a verbal acceptance of a value engineering change proposal by any employee of the Department shall not obligate the Department to accept the value engineering change proposal.
4. The contract officer may impose, as a condition of acceptance of any value engineering change proposal, a requirement that the contractor warrant the statements, claims, and other information contained in the value engineering change proposal. In addition, the contractor's responsibility under any such warranty shall be in addition to the liability imposed by the "guarantee of work" requirement as included in the contract.
5. The contractor shall be responsible for the new design of the facility or a portion of the facility submitted as a value engineering change proposal, including errors and omissions and, if the value engineering change proposal is for a portion of the facility, for any adverse impacts the new design may have on the unchanged portions of the facility.

D. **Conditions for a value engineering change proposal.**

1. A value engineering change proposal to a contract shall:
 - a. Result in an estimated net savings to the Department in the project cost of at least four thousand dollars (\$4,000.00) by providing less costly items than or using different construction methods from those specified in the contract without impairing any essential functions and characteristics as service life, reliability, substitutability, economy of operation, ease of maintenance, and necessary standardized features of the completed work;

- b. Require, in order to be applied to the contract, a change order to the contract; and
 - c. Not adversely impact on the performance schedule or the contract completion date.
2. As a minimum, the following information shall be submitted by the contractor with each value engineering change proposal:
- a. A description of the difference between the existing contract requirements and the value engineering change proposal and the comparative advantages and disadvantages of each including durability, service life, reliability, substitutability, economy of operation, ease of maintenance, desired appearance, design, safety standards, impacts due to construction, and other essential or desirable functions and characteristics as appropriate;
 - b. An itemization of the requirements of the contract which must be changed if the value engineering change proposal is adopted and are commendation as to how to make each change;
 - c. An itemized estimate of the reduction in performance costs that will result from adoption of the value engineering change proposal or parts thereof taking into account the costs of implementation by the contractor, including any amounts attributable to subcontractors, and the basis for the estimate;
 - d. A prediction of any effects and impacts the value engineering change proposal would have on: other costs to the Department as the costs of Department-furnished property, related items, and maintenance and operation over the anticipated life of the material, equipment, or facilities as appropriate; the construction schedule, sequence and time; and bid item totals used for evaluation and payment purposes;
 - e. A statement of the time by which a change order adopting the value engineering change proposal must be issued so as to obtain the maximum cost reduction during the remainder of the contract, noting any effect on the contract time; and
 - f. If previously submitted, the date(s) of any previous submission(s), the contract number(s) of those contract(s) for which it was submitted and the previous action(s) by the Department, if known;
3. When, in the judgment of the Contracting Officer, a value engineering change proposal alters the design prepared by a registered professional architect or engineer, the contractor shall ensure the changes to be prepared are by or under the supervision of a registered professional architect or engineer, and stamped and so certified.

4. A value engineering change proposal will be processed expeditiously and in the same manner as prescribed for any other proposal which would likewise necessitate issuance of a contract change order. Unless and until a change order applies a value engineering proposal to a contract, the contractor shall remain obligated to perform in accordance with the terms of the contract and the Department shall not be liable for delays incurred by the contractor resulting from the time required for the Department's determination of the acceptability of the value engineering change proposal. The determination of the procurement officer as to the acceptance of any value engineering change proposal under a contract shall be final.
5. The Contracting Officer may accept in whole or in part any value engineering change proposal submitted pursuant to this section by issuing a change order to the contract. Prior to issuance of the change order, the contractor shall submit complete final contract documents similar to those of the original contract showing the accepted changes and the new design and features as well as the following:
 - a. Design calculations;
 - b. The design criteria used; and
 - c. A detailed breakdown of costs and expenses to construct or implement such revisions. The change order will identify the final value engineering change proposal on which it is based.
6. When a value engineering change proposal submitted pursuant to this section is accepted under a contract, an equitable adjustment in the contract price and in any other affected provisions of the contract shall be made in accordance with this section and the "change order" clause of the contract. The equitable adjustment shall first be established by determining the effect on the contractor's cost of implementing the change, including any amount attributable to subcontractors and to the Department's charges to the contractor for architectural, engineering, or other consultant services and the staff time required to examine and review the proposal. The contract price shall then be reduced by fifty per cent (50%) of the net estimated decrease in the cost of performance.
7. The contractor may restrict the Department's right to use the data or information or both on any sheet of a value engineering change proposal or of the supporting data, submitted pursuant to this section, if it is stated on that sheet as follows:

"This data or information or both shall not be disclosed outside the Department, or be duplicated, used, or disclosed, in whole or in part, for any purpose other than to evaluate this value engineering change proposal. This restriction does not limit the Department's right to use this data or information or both if obtained from another source, or is otherwise

available, without limitations. If this proposal is accepted by the Department by issuance of a change order to the contract after the use of this data or information or both in such an evaluation, the Department shall have the right to duplicate, use and disclose any data or information or both pertinent to the proposal as accepted, in any manner and for any purpose whatsoever, and have others so do”.

8. In the event of acceptance of a value engineering proposal, the Department shall have all rights to use, duplicate, or disclose in whole or in part, in any manner and for any purpose whatsoever, and to have or permit others to do so, any data or information or both reasonably necessary to fully utilize such proposal.
9. Notwithstanding the provisions of this section, for any construction contract, the contractor shall not be precluded from making substitution requests in accordance with applicable rules and policies of the Department. The OIC shall be the sole judge of whether a proposal is a value engineering change proposal or a substitution request. (HAR §3-132-4)

E. **Value engineering sharing method.** The method by which the contractor will share a portion of the cost savings from an accepted value engineering change proposal shall be in accordance with section 3-132-4 and the following:

1. The contractor’s share in cost savings shall be for the single contract only, and no consideration shall be made for future acquisition, royalty type payment, or collateral savings.
2. The Department may accept the proposed value engineering change proposal, in whole or in part. The engineer shall issue a contract change order or modify the contract to identify and describe the accepted value engineering change proposal. (HAR §3-132-6)

5.8 SUBSTITUTIONS

A. **After Bid Opening.** Substitution of material or equipment may be allowed after the bid opening date only if:

1. The specified or prequalified item is delayed by a lengthy strike in the factory or other unforeseeable contingency beyond the control of the Contractor which would cause an abnormal delay in the project completion; or
2. All specified or prequalified items are found to be unusable or unavailable due to change or other circumstances; or
3. The Contractor is willing to provide a more recently developed or manufactured model of material or equipment of the same name manufacturer which the Contracting Officer determines to be equal or better than the one specified or prequalified.

A substitution request, regardless of reason, shall be fully explained in writing, by the Contractor including his justification for said request, quantities and unit prices involved, quotations and such other documents as are deemed necessary to support the request.

Any savings in cost will be rebated to the Department and any additional cost for the substituted items will be paid for by the Contractor.

The above shall not be construed to mean that substitutions for brand name specified materials and equipment will be allowed; the Contracting Officer reserves the right to reject and deny any request deemed irregular or not in the best interest of the Department and a request for substitution shall not in any way constitute a justification for an extension of contract time.

5.9 EXTRA WORK

No work of any kind in connection with the work covered by the specifications and plans shall be considered as entitling the Contractor to extra compensation except when the work is ordered in writing, as a change order, by the Contracting Officer.

5.10 PAYMENT FOR DELETED MATERIALS

- A. Canceled Orders – If acceptable material was ordered by the Contractor for any item deleted by an ordered change in the work prior to the date of notification of such deletion by the Contracting Officer, the Contractor shall use every reasonable effort to cancel the order. The Department shall pay reasonable cancellation charges required by the supplier excluding any markup for overhead and profit to the Contractor.
- B. Returned Materials – If acceptable deleted material is in the possession of the Contractor or is ultimately received by the Contractor, if such material is returnable to the supplier and the Contracting Officer so directs, the material shall be returned and the Contractor will be paid for the reasonable charges made by the supplier for the return of the material, excluded any markup for overhead and profit to the Contractor. The cost to the Contractor for handling the returned material will be paid for as provided in Subsection 5.4 “Price Adjustment.”
- C. Uncanceled Materials – If orders for acceptable deleted material cannot be canceled at a reasonable cost, it will be paid for at the actual cost to the Contractor including an appropriate markup for overhead and profit as set forth in Subsection 5.4 “Price Adjustment” In such case, the material paid for shall become the property of the Department of Water and the contractor shall deliver to the Department of Water Baseyard.

SECTION 6 - PERFORMANCE OF CONTRACT

6.1 TIME

Time is of the essence of the contract. Performance of the contract shall be commenced on the commencement date designated in the notice to proceed and shall be completed within the contract time specified in the contract or as computed or extended in accordance with the provisions of subsection 8.3.

- A. After the contract is completely executed, the Contracting Officer will issue the contractor a written "Notice to Proceed" designating the official date for the commencement of the work. The contractor shall submit all materials for approval. Once all materials for use on the project have been approved, the contractor shall arrange a preconstruction conference with the Contracting Officer, along with other affected agencies, firms and individuals at least ten (10) calendar days prior to the starting date for construction.

At the preconstruction conference, the contractor shall submit to the Department, the name, local address and telephone number(s) of his or her authorized superintendent of the job.

No construction work shall commence until the contractor has notified the Contracting Officer, in writing, at least one (1) week in advance of the actual date he or she will start the work to be done under the contract after the notice to proceed, and shall diligently prosecute the same to completion within the time limit provided in the contract. The contractor shall be entirely responsible for any delay in the work caused by his or her failure to give such notice to the Contracting Officer.

- B. When the contract time is on a working day basis, the Contracting Officer will furnish the contractor a weekly statement showing the number of days charged to the contract for the preceding week and the number of days specified for completion of the contract. The contractor will be allowed seven (7) days in which to file a written protest setting forth in what respect said weekly statement is incorrect; otherwise the statement shall be deemed to have been accepted by the contractor as correct.
- C. When the contract time is on a calendar-day basis, it shall consist of the number of calendar days stated in the contract beginning with the effective date of the NOTICE TO PROCEED, including all Sundays, holidays and non-working days. All calendar days elapsing between the effective dates of any orders of the Contracting Officer to suspend work and to resume work for suspensions not the fault of the contractor shall be excluded.

6.2 PERFORMANCE SCHEDULE

Within seven (7) calendar days after the commencement of the contract, or such further time as may be allowed by the Contracting Officer, the contractor shall submit for the approval of

the Contracting Officer, a practicable schedule utilizing the critical path method (CPM) for the performance of the contract. The date on which parts of the project, including the procurement of materials, plant and equipment, have been or will be started, and the contemplated dates for completion of parts of the project. If the schedule is not approved, it shall be revised as directed by the Contracting Officer. After approval, no changes in the schedule shall be made without the approval of the Contracting Officer. The approved schedule shall be updated with a three-week (3-week) schedule breakdown and two (2) copies submitted to the Department weekly, and a full schedule breakdown submitted to the Department monthly with payment request for approval. The updated schedule shall show the actual progress of work compared to the approved schedule or the latest amended schedule. The updated schedule shall be used as a basis for establishing major construction and as a check on the progress of the work performed under the contract. All schedules shall be provided via hard copy and as a Microsoft Project file/PDF file.

- * The full schedule shall include a written narrative explaining CPM network.
- * The full schedule shall account for dealing with predictable “planned (normal) adverse weather based on historical averages and be reflected appropriately.
- * The Contracting Officer does not dictate means, methods, or schedule as that is the contractors responsibility and discretion.
- * The Contracting Officer will review the CPM network for reasonableness and conformance with the plans, specifications and contract time at the baseline review and with each update.
- * Any acceleration to schedule pursuant to a directive by the owner shall be in writing.
- * Project float is a shared resource for use by contractor and owner in good faith.

6.3 OWNER-CONTRACTOR MEETING, FIELD OFFICE AND FIELD TELEPHONE

A. Owner-Contractor Meeting.

A weekly meeting is required at the jobsite field office. The meeting attendees at minimum shall be the contractor project manager and foreman, DOW project manager and inspector, and other construction related staff. The contractor shall prepare the meeting minutes and provide to the DOW construction team one day prior to next weekly meeting.

B. Field Office.

The contractor shall provide a field office for the Manager at a location designated by the Manager within the project site. It shall be available within seven (7) calendar days after issuance of Notice to Proceed for the work under the contract. The field office shall be weather-proof and not less than 120 square feet in gross floor area. The aggregate window areas of the office shall not be less than 10 percent (10%) of the floor area, and one (1) exterior door shall be provided with a keyed cylinder-type lock. The office shall be furnished with one (1) drafting-type table having a dimension of not less than 3' x 6' and a stool, adequate plan racks and hangers, one (1) desk, two (2) chairs, shelves, a broom, telephone service, air conditioning, electric lighting, paper towels, paper cups, soap, toilet paper and potable water, and shall be maintained in good repair and in a clean and sanitary condition by the contractor. If the office is not equipped with a water closet and lavatory, the contractor shall make other arrangements to provide such facilities for the Manager.

C. **Field Telephone.**

If required in the special provisions, the contractor shall provide a field telephone for the Manager. Such field telephone shall be placed at a convenient and accessible location.

6.4 DOCUMENTS TO BE KEPT ON SITE

The contractor shall keep a copy of the request for proposals, special provisions, current water system standards current standard specifications for Road and Bridge construction, approved construction drawings, approved submittals, RFI responses, approved permits, and specifications of the contract on the site of the project readily accessible for reference.

6.5 ADDITIONAL PLANS AND SPECIFICATIONS TO BE FURNISHED BY THE CONTRACTING OFFICER

If deemed necessary by the Contracting Officer, the Contracting Officer may furnish, by written order, such additional plans and specifications, during the performance of the contract as may be necessary to clarify the contract or define it in greater detail, and the contractor shall comply with such additional plans and specifications. Such additional plans and specifications shall become a part of the contract.

6.6 DRAWINGS TO BE FURNISHED BY CONTRACTOR

Shop drawings means drawings, submitted to the Department by the Contractor which shows in detail 1) the proposed fabrication and assembly of structural elements, and 2) the installation (i.e., form, fit, and attachment details) of materials or equipment. It includes drawings, diagrams, layouts, schematics, descriptive literature, illustrations, schedules, performance and test data and similar materials furnished by the Contractor to explain in detail specific portions of the work required by the contract.

The Contractor shall coordinate all such drawings, and review them for accuracy, completeness, and compliance with approved construction drawings, specifications and other applicable contract requirements and shall indicate its approval thereon as evidence of such coordination and review. The Contractor shall make and supply such working or shop drawings as may be required by the Contracting Officer during the performance of the contract. The drawings shall be finished plans, and shall be neat, legible and drawn to scale. Drawings submitted without evidence of the Contractor's approval may be returned for resubmission.

The contractor shall submit three (3) prints of working or shop drawings to the Contracting Officer for approval prior to the commencement of the work under the contract or the delivery to the project site of any equipment or material covered by the drawings, whichever is later. The Contracting Officer, has twenty (20) days to approve or disapprove and will indicate such approval or disapproval of the shop drawings. If not approved as submitted the Contracting Officer shall indicate the reasons therefor. The Contracting Officer may require the drawings to be resubmitted as often as necessary to render them complete, legible and free of extensive corrections. If a resubmittal is required, the Contracting Officer shall return one (1) print to the contractor who shall make all the corrections or drawings for

approval. Any work done before such approval shall be at the Contractor's risk.

After approval, no working or shop drawings shall be changed without the written approval of the Contracting Officer; and the contractor may proceed with the parts of the project called for in such drawings.

It shall be expressly understood that review and approval of working or shop drawings and other submittals by the Contracting Officer shall not be construed to relieve the contractor of responsibility for any errors and omissions in such drawings, or the accuracy of dimensions and details and duty to perform the contract in accordance with the approved construction drawings, specifications, terms, covenants, conditions, provisions and intent thereof. It is further understood that the review and approval by the Contracting Officer of the Contractor's shop drawings, whether general or detailed, is a general review relating only to their sufficiency and compliance with the intention of the contract. The Contractor shall clearly identify and inform the Contracting Officer in writing on the shop drawing transmittal cover sheet of any deviations from the contract documents at the time of submission and shall obtain the Contracting Officer's written approval to the specified deviation prior to proceeding with any work. The contractor, at his own risk and expense, may elect to proceed with the work affected by the drawings prior to final review.

Catalog cuts or similar reproductions may be substituted for working or shop drawings in the case of assembled electrical, mechanical units and other waterworks materials to be installed, when they show information which the Contracting Officer determines to be sufficient for review and approval. The contractor shall provide all additional information that is requested by the Contracting Officer during the review and approval process.

6.7 OMISSION IN CONTRACT

Unless specified, work which is otherwise incidental to the contract although not specifically referred to in the contract shall be furnished and performed by the contractor. Labor, materials, equipment, overhead, and extended overhead directly or indirectly necessary to complete the construction of the project, whether or not the same may have been expressly provided for in the contract, shall be furnished and performed by the contractor.

6.8 CONTRACTOR TO REPORT ERRORS OR DISCREPANCIES

The contractor shall notify the Contracting Officer in writing immediately upon discovery of any error or omission in the layout given by stakes, points or instructions furnished by the Manager, or any discrepancy within the contract, or any part thereof or between the plans and the conditions of the site.

After such discovery, the contractor shall proceed with the performance of the contract only after receiving written approval from the Contracting Officer.

6.9 CONTROL OF THE CONTRACT

A. Workmanship.

The contract shall be performed in an orderly and workmanlike manner in

accordance with the latest acceptable practice and shall be of the best quality, except as clearly specified otherwise. Whenever there is a doubt as to what is permissible or the contract fails to note the quality of any work, the interpretation which calls for the best quality of work is to be followed.

B. Access to the Project.

During the performance of the contract, the contractor shall provide the Department with proper and safe facilities for access to the site of the project and the shops of the contractor and the subcontractor.

Other contractors of the Department shall be permitted access to the site of the project when it is required for performance of their respective contractors.

C. Inspection.

The performance of the contract shall be subject to the inspection of the Department, and the contractor shall supply such information and assistance as may be required to make a complete and detailed inspection. The Department may inspect each and every subdivision of the work or any part or parts or process thereof. The Department's staff shall have free access to all parts of the work at all times and shall be given every facility, information, and means of thoroughly inspecting the work done and the materials used or to be used. No work or material which may be defective in construction or quality or deficient in any of the requirements of the plans, specifications, special provisions or other contract documents will be accepted. The Department's presence or inspection on the site will not relieve the contractor of his or her deficiencies.

If the contractor wishes to work at such time of the day which is during the period other than the regular business hours of the Department of Water, County of Kaua'i or on a Saturday, Sunday or legal State holiday, he or she shall make a written request for inspectional services during such period. If such a request is made and granted, the contractor shall notify the Contracting Officer not less than twenty-four (24) hours in advance of the time when the inspectional services are required. The contractor shall pay the Department at the rate per hour designated by the Department for each employee provided pursuant to this paragraph.

D. Inspection of Plant or Site, Access to Plant or Place of Business.

1. Inspection of plant or site. Circumstances under which the Department may perform inspections include, but are not limited to, inspections of the Contractor's plant or site in order to determine: Whether the standards set forth in section 3-122-108, Hawai'i Administrative Rules, have been met or are capable of being met; and if the contract is being performed in accordance with its terms. (HAR 3-122-166)
2. Access to plant or place of business. The Department may enter a Contractor's or subcontractor's plant or place of business to:
 - a. Inspect goods or services for acceptance by the Department pursuant to the terms of a contract;

- b. Audit cost or pricing data or audit the books and records of any Contractor or subcontractor pursuant to section 3-122-175, Hawai'i Administrative Rules; and
- c. Investigate in connection with an action to debar or suspend a person from consideration for award of contracts pursuant to sections 3.126-11 through 3-126-18, Hawai'i Administrative Rules. (3-122-167,8)

E. **Samples and Test Specimens.**

When required by the Contracting Officer, test specimens or samples of materials, equipment, instruments, pipes and fittings and other Waterworks appurtenances to be used or offered for use in the performance of the contract shall be prepared and furnished by the contractor in such quantities and sizes as may be required for proper examination and tests, with information as to their sources.

The contractor shall furnish additional test specimens and samples as directed.

Test specimens and samples shall be submitted in ample time to enable the Department to make such tests or examinations as may be necessary. Laboratory tests and examinations made in a laboratory other than that of the Department shall be at the expense of the contractor.

F. **Tests.**

Tests specified by the contract, statute, regulation, Water Standards, or ordinance shall be made; and the cost thereof shall be borne by the contractor unless otherwise provided for in such contract, statute, regulation or ordinance. Such tests shall be conducted under the direction of the Contracting Officer, and the contractor shall repair any damage resulting there from.

In addition, the Contracting Officer may require such tests as he or she deems necessary to carry out his or her duties during the performance of the work under the contract. When a test is required by the Contracting Officer, the contractor under the direction of the Contracting Officer shall conduct such test and shall bear all of the costs, including the cost of tools, labor and materials necessary therefor.

G. **Site Access.**

The contractor shall provide access to the work at all times to representatives of the Department of Federal Environmental Protection agency, the State of Hawai'i Water Pollution Control, State Department of Health, and any other authorized Federal, State or County Agencies whenever the work is in preparation or in the process, and shall provide proper facilities for such access and inspection. In addition, authorized representatives of the Department and the County shall have access to any books, documents, papers and records of the contractor which are pertinent to the project for the purpose of making audit, examinations, excerpts, and transactions thereof.

H. **Removal of Defective and Unauthorized Work.**

All work which has been rejected as not conforming to the requirements of the contract shall be remedied or removed and replaced by the Contractor in an

acceptable manner at no cost to the Board. Any work done beyond the work limits shown on the plans and specifications or established by the Contracting Officer, as authorized under the terms of the Contract, or any additional work done without written authority will be considered as unauthorized and will not be paid for. Work so done may be ordered removed at the Contractor's expense. Upon failure on the part of the Contractor to comply promptly with any order of the Contracting Officer made under the provisions of this subsection, the Contracting Officer shall have authority to cause defective work to be remedied or removed and replaced and unauthorized work to be removed and to deduct the costs from any monies due or to become due the Contractor.

6.10 PERSONAL SUPERVISION

The contractor shall be present on site in person, or by a responsible agent with authority to act for the contractor in connection with the contract during the performance of the contract.

The contractor shall file with the Contracting Officer a written statement signed by the contractor giving the names of the designated competent person(s) for trench excavation and confined space entry, any and all supervisors, foreman and employees who are authorized to act in place of the contractor, and any communication signed in behalf of the contractor by such agents immediately and in writing of any change in the name or names so submitted.

6.11 CHARACTER OF WORKMEN, METHODS AND EQUIPMENT

The Contractor shall at all times provide adequate supervision and sufficient labor and equipment for prosecuting the several classes of work to full completion of the project in the manner and within the time required by the contract.

- A. Character and Proficiency of Workers. All workers must have sufficient skill and experience to perform properly the work assigned to them. All workmen engaged in special work or skilled work such as bituminous courses of mixtures, concrete pavement or structures, electrical installation, plumbing installation, or in any trade shall have sufficient experience in such work and in the operation of the equipment required to properly and satisfactorily perform all work. All workers shall make due and proper effort to execute the work in the manner prescribed by the Contract; otherwise, the Contracting Officer may take action as prescribed herein. Any worker employed on the project by the Contractor or by any subcontractor who, in the opinion of the Contracting Officer, is not careful and competent, does not perform his work in a proper and skillful manner or is disrespectful, intemperate, disorderly or neglects or refuses to comply with directions given, or is otherwise objectionable shall at the written request of the Contracting Officer, be removed forthwith by the Contractor or subcontractor employing such worker and shall not be employed again in any portion of the work without the written consent of the Contracting Officer. Should the Contractor or subcontractor continue to employ, or again employ such person or persons on the project, the Contracting Officer may withhold all monthly payments which are or may become due, or the Contracting Officer may suspend the work until such orders are complied with, with no adjustment in contract end date being made.

- B. **Insufficient Workers.** In the event that the Contracting Officer, in his judgment, finds the condition whereby insufficient workers are present to accomplish the work and no corrective action is taken by the Contractor after being informed, the Contracting Officer reserves the right to terminate the contract as provided for under Section 8 REMEDIES.

- C. **Equipment Requirements.** All equipment furnished by the Contractor and used on the work shall be of such size and of such mechanical condition that the work can be prosecuted in an acceptable manner at a satisfactory rate of progress and the quality of work produced will be satisfactory.

Equipment used on any portion of the project shall be such that no injury to the work, adjacent property or other objects will result from its use. If the Contractor fails to provide adequate equipment for the work, the contract may be terminated as provided under Section 8 REMEDIES.

In the event that the Contractor is paid for furnishing and operating equipment on a force account basis, it shall be operated as directed by the Contracting Officer in order to obtain maximum production under the prevailing conditions.

6.12 WAGES AND HOURS

Contractors shall observe and comply with all the provisions of Chapter 104, HRS, relating to wages and hours of employees on public works. The contractor shall pay all employees on any contract with the Department, the minimum basic wage rate in conformance with applicable Federal and State laws.

The minimum wages shall be periodically increased during the performance of a contract in an amount equal to the increase in the prevailing wages for those kinds of work as periodically determined by the State Director of Labor and Industrial Relations. Notwithstanding the provisions of the original contract entered into, if the Director of Labor and Industrial Relations determines that the prevailing wage has increased, the rate of pay of laborers and mechanics on the contract shall be raised accordingly. Offerors shall take into consideration increases which may occur during the period of the contract in computing their bid or proposal prices. No additional compensation shall be made for failure to do so.

The current State Wage Rate Schedule and any addenda is incorporated in this document by reference only. Copies are available the State Department of Labor and Industrial Relations, 830 Punchbowl Street, Honolulu, HI 96813, or at the State website:

<http://hawaii.gov/labor/rshttp://labor.hawaii.gov/wsd/files/2013/02/104-2FAQ-Rev-3-09.pdf>

No labor or mechanic employed on the job site shall be permitted or required to work on Saturday, Sunday, or a legal holiday of the State of Hawai'i in excess of eight (8) hours on any other day unless the laborer or mechanic receives overtime compensation for all hours worked on Saturday, Sunday, and a legal holiday of the State or in excess of eight (8) hours on any other day. For purposes of determining overtime compensation under this subsection, the basic hourly rate of any laborer or mechanic shall not be less than the basic

hourly rate determined by the Director of Labor and Industrial Relations to be the prevailing basic hourly rate for corresponding classes of laborer and mechanics on projects of similar character in the State.

A certified copy of all payrolls shall be submitted weekly to the Manager. The contractor shall be responsible for the submission of certified copies of the payrolls of all subcontractors. The certification shall affirm that the payrolls are correct and complete, that the wage rates contained therein are not less than the applicable rates contained in the wage determination decision of the Director of Labor and Industrial Relations attached to the contract, and that the classifications set forth for each laborer or mechanic conform with the work the laborer or mechanic performed.

If the Contracting Officer finds that any laborer or mechanic employed on the job site by the contractor or any subcontractor has been or is being paid wages at a rate less than the required rate by the contract or the specifications, or has not received the laborer's or mechanic's full overtime compensation, the Contracting Officer may take appropriate action in accordance with Section 104-4, HRS, or the Contracting Officer may, upon recommendation of the Contracting Officer, by written notice to the contractor, terminate the contractor's right, or the right of any subcontractor, to proceed with the work or with the part of the work in which the required wages or overtime compensation have not been paid and may complete such or part by contract or otherwise, and the contractor and the contractor's sureties shall be liable to the Department for any excess costs occasioned thereby.

The contractor is required to post the applicable wage schedule in a prominent and easily accessible place at the job site. The contractor shall give to each laborer and mechanic employed under the contract a copy of the rates of wages required to be posted.

On federally funded or federally assisted projects, the current federal wage rate determination in effect at the time of advertising for bids or proposals is incorporated as part of the invitation for bids or proposals, and both State and federal wage rates shall apply. Where rates for any class of laborers and mechanics differ, the higher rates shall prevail. The minimum federal wage rates shall be those in the U.S. Department of Labor Wage Determination Decision and Modifications in effect five (5) calendar days prior to the bid or proposal opening date.

6.13 CONTRACTOR'S ADDRESS

The contractor shall provide and maintain a post office address within the State of Hawai'i and file the same with the Contracting Officer. Any written order or notice which may be required or desirable under the contract may be served on the contractor personally, or delivered to his or her representative on the project site, or left with a member of his or her family of suitable age and discretion at his or her residence, or with any employee of the contractor at his or her place of business and/or mailed to the aforesaid local post office address. All orders or notices shall become effective when mailed or at the time of service or delivery as aforesaid.

6.14 OBSTRUCTIONS

The Contractor shall remove all obstructions, the removal of which shall be necessary for the proper reception, performance, construction, installation, and completion of all work under this contract, as called for or implied in the plans and specifications, and is considered incidental work.

6.15 SURVEYS AND CONSTRUCTION STAKES, LINES AND GRADES

All lines, levels and elevations are to be laid out and checked by a surveyor or civil engineer licensed in the State of Hawai'i at the contractor's expense. The contractor shall furnish a certificate or document signed by the surveyor or civil engineer certifying that the completed lines, levels and elevations are in conformity with the contract. The contractor shall verify all lines, levels and elevations indicated in the contract before any excavation or construction begins. Any discrepancy shall be immediately brought to the attention of the Manager and any change shall be made in accordance with his or her instruction. The contractor shall not be entitled to any additional payment if he or she fails to report the discrepancies before proceeding with work within the area affected by the discrepancies.

6.16 SUBCONTRACTING

The contractor shall not subcontract any part of the contract except to those subcontractors specifically listed in the bid or proposal submitted by the contractor; provided, however, the contractor may for good cause and upon written approval of the Contracting Officer engage other subcontractors. Engaging subcontractors to perform the work under the contract shall not relieve the contractor of his or her duty to perform the contract in accordance with the terms, covenants, conditions, provisions and intent thereof. The contractor shall replace a subcontractor when required by the Contracting Officer for not performing the contract in accordance with the terms, covenants, conditions, provisions and intent thereof.

6.17 OTHER CONTRACTS

The contractor shall coordinate his or her operations with those of other contractors who may be employed on adjacent or related projects of the State, County, Department or private development, shall avoid interference therewith, and shall cooperate with the other contractors so as to avoid unnecessary delay or hindrance in the performance of their respective contracts. Any difference or conflicts which may arise between the contractor and other contractors of the State, County, Department or private development in regard to their projects shall be adjusted and determined by the Department's staff, whose decision and order shall be final and binding.

6.18 WATER REMOVAL

The contractor shall examine the site of the project and make all necessary arrangements with affected property owners for the removal of water from the site. The contractor shall provide a bridge or other facilities to prevent water flowing into adjacent properties and adjacent streets as a result of his or her activities, from interfering with the traffic on such streets.

6.19 ELECTRICAL, TELECOMMUNICATION AND WATER SERVICE

The contractor shall make his or her own arrangements for electrical, telecommunication and water services required for the performance of the contract at his or her expense. The Contractor shall be responsible for scheduling and coordinating the work with the utility companies and applicable governmental agencies for temporary and permanent service connections. The Contractor will pay the utility companies and applicable governmental agencies directly for such connections upon receipt of the state of charges.

The contractor or subcontractor will not be charged for the final filling of any new or refurbished tank if a temporary hydrant meter is used. For example, a new or refurbished 0.5 MG Tank will be credited 500,000 gallons. All other usage of the temporary hydrant meter such as, but not limited to, testing of new waterlines, irrigation, and dust control will be charged to the contractor.

6.20 UTILITIES UNDERGROUND

Prior to offer: All underground waterlines and appurtenances, gas, oil, telephone, television, electric, storm drain, fiber optic, sewer and other pipes or conduits, if shown on the plans, are only approximate in their locations. Prior to bid or proposal, the contractor shall make a personal investigation and inspection of the records of the owners of the utilities, supplemented by actual digging in the field, if necessary, to determine the actual locations of such utilities with all their branch and service lines whether indicated on the plans or not. Consequences resulting from the Contractor's failure to do so will be the sole cost and responsibility of the Contractor.

Prior to installation of new facilities: The contractor shall make satisfactory arrangements with the owners of the utilities for the relocation, maintenance and protection of existing utilities and shall furnish the Department's staff with evidence in writing that satisfactory arrangements have been made not less than ten (10) days before the commencement of the parts of the project under the contract affecting such utilities. Further, the Contractor shall probe the project area to verify existing utilities shown or not shown on the approved construction drawings and indicate potential conflicts with new facility installation. If required, the Department will consider redesign of the new facilities to deal with the potential conflicts. Consequences resulting from the Contractor's failure to do so will be the sole cost and responsibility of the Contractor.

6.21 QUALITY OF MATERIALS AND EQUIPMENT

Unless otherwise specifically stated in the specifications, all workmanship, equipment, materials and articles incorporated in the work covered by this contract are to be of the best available grade of their respective kinds. Whenever specifications for any material, article, device, product, fixture, form, type of construction or process is indicated or specified by patent or proprietary name, by name of the manufacturer or by catalog number, such specifications shall be deemed to be used for the purpose of establishing a standard of quality and to facilitate the description of the material or process desired and shall be deemed to be followed by the words "or equal."

All materials and equipment furnished and installed under this contract shall be new and must be of standard quality of their respective kinds, free from all defects which may render them unfit for use. The contract contemplates the use of first-class materials and equipment

throughout the performance of the contract, and it is agreed that any material and equipment for which no particular specification is given shall be of the highest quality of its class or kind. The Manager will not accept materials and equipment that do not conform to the contract.

Rejected materials and equipment shall be removed immediately from the work and replaced with materials and equipment of the required quality. Should the contractor fail to remove such rejected materials and equipment within twenty-four (24) hours after notice by the Contracting Officer, the latter may remove such rejected materials and equipment and deduct the expense therefor from any sum due or to become due the contractor. Failure to reject any material and equipment or to remove any rejected material and equipment shall not relieve the contractor from responsibility as to the quality and character of materials and equipment used or as to any other obligation imposed upon him by the contract.

6.22 NATIONAL SANITATION FOUNDATION (NSF) APPROVALS

All materials used in Waterworks construction (pipe, pipe lubricants, paints, sealants, form oil, concrete admixtures, etc.) in direct contact with the potable water shall be approved by the National Sanitation Foundation (NSF). The contractor shall submit these approvals to the Contracting Officer for review and approval prior to its application.

6.23 SAMPLES

Whenever requested by the Contracting Officer, the contractor shall furnish samples of materials to be used in the performance of the contract. Said samples if approved, will be retained by the Contracting Officer and, subject to his or her order, shall be used as the standard with which all like materials furnished under the contract must conform. The approval of any sample tested by the Contracting Officer or his or her failure to require the furnishing of samples shall not relieve the contractor from performing the work in accordance with the contract.

6.24 PROTECTION OF PEDESTRIANS AND VEHICULAR TRAFFIC

During the progress of the work, the contractor shall use all proper precautions and methods of procedure and construction by means of good and sufficient barriers, guards, temporary bridges, notices, lights, warning and other safeguards for the prevention of accidents and for the protection of persons and property, and from sunset until sunrise he or she shall keep suitable lights burning wherever the public has access near or at the work in progress to define the line of safe passage. The Contractor shall defend, indemnify and save harmless the Department and Board against any and all suits, actions and claims for cost, compensation, damages or otherwise to which the said Department may be put on account of injury to person or property of another, resulting from negligence of the contractor in the performance of the work or the guarding of the same; and he or she shall include in his or her bond such terms as will protect the Department and Board against any loss, charge or expense by reason of any such claims, suits or actions.

A. Public Convenience.

The contractor shall so conduct his or her operations as to offer the least possible obstruction and inconvenience to the public and he or she shall have under

construction no greater length or amount of work than he or she can prosecute properly with due regard to the rights of the public.

Unless otherwise provided in the special provisions, all public traffic shall be permitted to pass through the work with as little inconvenience and delay as possible.

Spillage resulting from hauling operations along or across any public travel way shall be removed immediately by the contractor at his or her expense.

Construction operations shall be conducted in such a manner as to cause as little inconvenience as possible to abutting property owners.

Convenient access to driveways, houses, mail boxes and buildings along the line of the work shall be maintained and temporary approaches to crossings or intersecting highways shall be provided and kept in good condition.

Water or dust palliative shall be applied if ordered by the Manager for the alleviation or prevention of dust nuisance at all times, regardless of whether or not work is being performed on the site.

B. Public Safety

The contractor shall comply with all requirements and provisions of the Federal, State and County safety laws, including Hawai'i Occupational Safety and Health (OSHA) Laws, and all building and construction codes, and shall take all necessary precautions for the safety of all employees on the project.

Wherever the contractor's operations create a condition hazardous to traffic or to the public, he or she shall furnish, erect and maintain, at his or her expense and without cost to the Department, such fences, barricades, lights, signs and other devices as are necessary to prevent accidents or damage or injury to the public.

Should the contractor appear to be neglectful or negligent in furnishing warning and protective measures as above provided, the Contracting Officer may direct attention to the existence of a hazard and the necessary warning and protective measures shall be furnished and installed by the contractor at his or her expense.

Should the Contracting Officer point out the inadequacy of warning and protective measures, such action on the part of the Contracting Officer shall not relieve the contractor from responsibility for public safety or abrogate his or her obligation to furnish and pay for these devices.

The installation of general roadway illumination shall not relieve the contractor of his or her responsibility for furnishing and maintaining any of the protective facilities hereinbefore specified.

C. Accidents.

The contractor must promptly report in writing to the Manager all accidents whatsoever arising out of or in connection with the performance of the work,

whether on or adjacent to the site which caused death, personal injury or property damage, giving full details and statements of witnesses. In addition, if death or serious injuries or serious damage is caused, the accident shall be reported immediately by telephone or by messenger to the Manager.

If any claim is made by anyone against the contractor or any subcontractor on account of any accident, the contractor shall promptly report the facts in writing to the Manager, giving full details of the claim. It is understood and agreed that the written report of any accident shall not relieve the contractor of the responsibility, and the Department and Board shall not be held responsible.

D. Non-compliance.

The Manager will notify the contractor of any non-compliance with the foregoing provisions and the action to be taken. If the contractor fails or refuses to comply promptly, the Contracting Officer, with the approval of the Contracting Officer, may issue an order stopping all or part of the work until satisfactory corrective action has been taken. No extension of time or payment for excess costs or damage shall be made for the time lost due to such stop action.

If no corrective action is taken by the contractor within twenty-four (24) hours after a suspension is ordered by the Contracting Officer, the Department reserves the right to take whatever action is necessary to correct the situation and to deduct all costs incurred by the Department in taking such action from moneys due the contractor.

The Contracting Officer may also suspend any operations which he or she feels are creating safety problems. The Department's failure to act pursuant to this section shall not be considered a liability and failure on the Department's part to act shall not be considered a waiver to any rights and remedies to which the Department is entitled.

6.25 ACCESS TO PROPERTY

The contractor shall provide safe access to the property abutting the site of the project when the usual means of access are obstructed by the performance of the contract.

6.26 PROJECT SIGN

The contractor shall provide signs to identify the project. The signs shall be erected at locations designated by the Contracting Officer at the site of the project upon commencement of the work under the contract. Signs shall be properly erected and kept clean and legible. After completion of the work under the contract and final acceptance thereof, the contractor shall remove the signs.

The Contractor shall assume all responsibilities in maintaining the sign in good legible condition and free from any damage during the entire construction period, and shall make good all such repairs at no cost to the Department.

6.27 PROJECT MAY BE PLACED IN SERVICE

The Department may place parts of the project in service as completed and the contractor shall give proper access to such portions for this purpose. Use of the portions so placed in service by the public shall constitute an acceptance by the Department of such portions of the project involved but shall not constitute total completion nor shall it constitute final acceptance . The Department does not recognize the concept of substantial completion to avoid liquidated damages.

6.28 PRECAUTIONS AND RESTORATION

The contractor shall protect property adjacent to the site of the project from damage and shall restore property damaged by him to the condition it was in prior to the damage. Prior to starting any work, the contractor shall photograph and video the existing conditions of structures, landscaping, etc. that are to remain within the project and any staging areas. Any existing defects, damages, etc. shall be noted and forwarded in writing to the Department of Water. Any damage to existing items noted during or after completion of the project that were not specifically reported in writing prior to starting any work shall be repaired and replaced by the contractor at no cost to the Department.

A. Existing Utilities and Structures.

The existence and location of underground utilities and structures as shown on the plans are from the latest available data but are not guaranteed as to their actual existence or location. Other obstacles not shown on the plans may be encountered in the course of the work.

The contractor shall make a personal investigation and inspection of the records of the owners of the utilities, supplemented by actual digging in the field if necessary to determine the actual locations of such utilities with all their branch and service lines whether indicated on the plans or not. The contractor shall furnish the Manager with written evidence that the contractor has contacted all the utility companies.

The contractor shall be held responsible for any damage to and for the maintenance and protection of existing utilities and structures whether shown on the plans or not.

The contractor shall also completely protect all buildings, pavements, gutters, curbs, sidewalks, driveways, walls, fences, pipes, drains, conduits, or other structures of all classes, nature or types from settlement or other damage by installing proper underpinning, sheet piling and bracing and by taking all proper precautions during the period of construction. The contractor shall be responsible for the settlement of any pavement, building or any other structure of any class, nature or type caused by the dewatering of trenches or from any other cause relative to the work of the contractor and he or she shall in all cases be held liable for any damage to any building, structure or property along the line of the work.

Should it become necessary to remove, replace, obstruct, alter or use any existing pipe, hydrant, conduit, pole or other equipment or structure of any kind, the contractor shall make all necessary arrangements with the Department, State, County, corporation, company or any other organization owning or controlling the same relative to the removal, replacement, obstruction, alteration, use, damage and the payment therefor and shall furnish the Contracting Officer with evidence in

writing that satisfactory arrangements have been made, not less than ten (10) calendar days before removing, replacing, altering, using or obstructing the equipment or structure concerned.

B. **De-watering.**

De-watering shall be accomplished by suitable means; this includes the Contractor obtaining the required NPDES permits for de-watering. The contractor shall repair any and all damages resulting to improvements from such de-watering operation to the satisfaction of the owners of such improvements.

C. **Grass.**

When grassed areas are disturbed, the area shall be carefully graded and replanted with similar grass placed not over 6"x 6" center to center, leaving the area substantially similar to the condition it was in prior to the excavation.

D. **Trees, Plants and Shrubbery.**

All trees shall be carefully protected and kept from contact with excavation or other materials. Where it is necessary to trim trees, plants or shrubs, the contractor shall employ licensed tree trimmers. Branches shall be carefully trimmed so that the trees, plants or shrubs are not damaged. All cut sections of branches shall be painted with tree seal compound. All grass, plants, trees or shrubs removed or destroyed shall be replaced by the contractor to the satisfaction of the Department, corporation, company or any other organization owning or controlling the area where this work is to be done. All costs thereof shall be considered incidental.

E. **Property Marks.**

The contractor shall reference and replace marks, stakes, pipes, monuments of the property line and similar objects which may be disturbed by the contractor while performing the contract.

F. **Environmental Pollution Control.**

The contractor shall comply with the following requirements for pollution control in performing all construction activities. The contractor shall be responsible for conformance to all federal, state and county laws regarding environmental pollution control, including Chapters 37 and 37-A the Public Health Regulations, Department of Health, State of Hawai'i, as amended, during construction.

1. **Erosion and Sediment Control.**

- a. Soil protection facilities shall be completed as early as practicable. Sections of bare earth and the length of their exposure to erosion shall be minimized by proper scheduling and limiting the work areas. Temporary berms, cut-off ditches, and other provisions which may be required because of the contractor's method of operation shall be installed at no cost to the Department. Also, the contractor shall continue such measures until establishing the protective ground cover sufficiently to be an effective erosion deterrent. If material begins to erode into a river, stream or impoundment, the contractor shall act immediately to bring the situation under control.

Surface drainage from cuts and fills within the construction limits and from borrow and waste disposal areas shall, if turbidity producing materials are present, be held in suitable sedimentation ponds or shall be graded to control erosion within acceptable limits.

The contractor shall restrict construction operations in rivers, streams, lakes and reservoirs where channel changes are shown in the contract. Also, the contractor shall restrict construction operations to those areas that are entered for the construction of temporary or permanent structures. The contractor shall clear rivers, streams, lakes and reservoirs promptly of water pipes, fittings, false work, piling, drill cuttings, debris, or other obstructions.

The contractor shall not deposit excavated material in or near rivers, streams, lakes and reservoirs and shall at all times comply with the Federal Clean Water Act, 33 U.S.C. §1251 et seq. and any other applicable laws.

The contractor shall not permit fording of streams with construction equipment. The contractor shall use temporary bridges or other structures wherever stream crossings are necessary. The contractor shall not operate mechanized equipment in streams except to construct channel changes and temporary or permanent structures. The contractor shall avoid or minimize interferences with the movement of migratory fish.

2. Landscape Preservation, Forest and Well Source and Water Facilities Protection.

The contractor shall conform to Federal, State and County laws, statutes, ordinances, rules and regulations, including the Department of Water and Fire Department, State Department of Land & Natural Resources governing the protection of forests, well sources and water sheds, and the performance of work in these areas.

The contractor shall keep the project area in an orderly condition, dispose refuse, and obtain permits for the construction and maintenance of Department's water facilities and appurtenances according to the State Forester requirements.

The contractor shall take precaution and assist in preventing and suppressing forest fires. The contractor shall notify a Forest official of the location and amount of fire.

The contractor shall avoid or minimize disturbance to game preserves, water sheds and operations of the State Forester and Department of Water.

3. Waste Disposal.

a. Care shall be exercised to insure that disposal of waste from construction operations do not create pollution problems.

- b. Disposal of any materials, waste, effluent, trash, garbage, oil, grease, chemicals, etc., in areas adjacent to streams shall be subject to the approval of the Manager.
- c. No burning of debris and/or waste materials shall be permitted on the project site.
- d. No burying of debris and waste materials except for materials which are specifically indicated elsewhere in the bid or proposal document as suitable for backfill shall be permitted on the project site.
- e. All unusable debris and waste materials shall be hauled away to an appropriate off-site dump area. During loading operations, debris and waste materials shall be watered down to allay dust.
- f. Frequency of cleanup shall coincide with rubbish producing events.

4. Dust Control.

Dust, which could damage crops, orchards, cultivated fields, Department's water facilities, public and private facilities, business establishments and dwellings or cause nuisance to persons, shall be abated and control measures shall be performed at all times, including non-working hours, weekends and holidays. The cost for all dust control sprinkling shall be paid for by the contractor and shall extend for the entire period of construction. The contractor shall be held liable for any damage resulting from dust originating from his or her operations.

5. Waste Water.

Construction operations shall be conducted so as to prevent discharge or accidental spillage of construction water, pollutants, solid waste, debris and other objectionable wastes in surface waters and underground water sources.

6. National Pollutant Discharge Elimination System (NPDES) Permit and other Water Discharge Permits.

The contractor shall review and become familiar with the latest requirements of the NPDES Permit as issued by the State Health Department and all other necessary permits to discharge water into the waterways prior to bidding or proposing on this project. All inquiries for this permit shall be coordinated with the State Health Department.

Immediately after the award of the construction contract, the contractor shall meet with the Contracting Officer to complete the applications for a Department of Health NPDES Permit and for all other permits that may be required to discharge water into waterways. The Contractor shall be the duly authorized representative of the Department of Water as it relates to NPDES requirements.

Notice to proceed will not be delayed due to the contractor's inability to

meet NPDES Permit requirements in a timely manner.

See Exhibit N for Best Management Practices (BMP) inspection report to be used during construction as NPDES permit compliance verification. The BMP report shall be submitted on a weekly basis to the Contracting Officer.

7. Noise Control.

The Department of Health's Chapter II-46, Hawai'i Administrative Rules, Community Noise Control, establishes statewide noise rules on community noise.

This statewide noise rule complies with Chapter 342F, Hawai'i Revised Statutes, which states that the Director of Health shall present, control and abate noise pollution in the state.

In reference to construction activities, community noise permit applications are required for construction operations which exceed, or are anticipated to exceed noise standards established in the rules. The significance of the community noise permit is to allow for construction operations to exceed the noise standards, while allowing the Department of Health to monitor such activities to assure adequate protection of public health and welfare from adverse noise impacts.

The following activities related to construction operations are exempt from the provisions of the rules:

- a. Activities related to the emergency maintenance and repair of state and county highways, parks, and public utilities including but not limited to water, sewer, electric, gas, and telephone systems, provided the noise is confined to only the equipment in use.
- b. Backup alarm devices on any vehicle, where such device is required by federal or state occupational safety and health regulations.
- c. Construction and remedial activities related to the emergency repair of damages caused by natural disasters, including but not limited to tsunamis and hurricanes.

The contractor shall be responsible to obtain all permits and provide the Manager with a copy. The contractor shall pay for all applicable permit fees.

8. Others

- a. Whenever trucks and/or vehicles leave the site and enter surrounding paved streets, the contractor shall prevent any materials from being carried onto the pavements.
- b. Trucks hauling debris shall be covered as required by PUC regulations. Truck hauling fine materials shall be covered.

- c. No dumping of waste concrete will be permitted at the job site unless otherwise permitted in the Special Provisions.
- d. Except for rinsing of the hopper and deliver chute, and for wheel washing where required, concrete trucks shall not be cleaned on the job site.
- e. Except in an emergency, such as mechanical breakdown, all vehicle fueling and maintenance shall be done in designated areas. A temporary berm shall be constructed around the area when runoff can cause problems.
- f. Spray painting will not be allowed unless done by the “airless spray” process.

9. Payment

The cost of environmental pollution control shall not be considered incidental and shall be included in the price of offer for the various items of work.

G. Archaeological, Historical, and Burial Site Findings

Whenever the contractor encounters possible archaeological, historical or burial site findings, the contractor shall immediately suspend the operation and inform the Contracting Officer verbally and follow up with a written letter. The Contracting Officer will notify the proper authorities to evaluate such findings and decide the course of action.

The contractor shall not resume suspended operations without the prior written acceptance of the Manager. Delays resulting from the discovery, investigation, and handling of such findings shall extend the completion date. The Contracting Officer will govern suspensions of work according to subsection 8.3 of these General Provisions. Also, the contractor shall conform to Chapter 6E, H.R.S. relating to Historic Preservation, as amended.

Construction work and equipment shall remain within the right-of-way limits of this project.

The Archaeologist will decide the limits of the site. Also, the Archaeologist will decide, with the Manager, the best means for protecting the site from further disturbances which requires further investigation or salvage as determined by the State Historic Preservation Officer. Protection may include barricades, roping off, temporary fencing or other means.

H. Protection of Fish and Wildlife

The contractor shall at all times perform all work and take such steps to prevent any interference or disturbance to fish and wildlife. The Contractor shall be solely liable for any fees or costs associated with failure to take the proper and necessary steps to prevent such interference and agrees to defend, indemnify, and hold harmless the

Department from any actions arising out of the failure to take the proper and necessary steps to prevent such interference to fish and wildlife.

I. **Subcontractors**

Compliance with the provisions of this subsection by the subcontractors will be the responsibility of the contractor.

J. **Health and Safety Compliance**

1. **Safety Program.** The Contractor shall comply with chapter 396, HRS, relating to the standards of occupational safety and health and all applicable Federal, State and County laws and regulations, including but not limited to section 396-18, HRS, relating to safety and health programs for contractors for Department construction projects where the proposal amount is in excess of \$100,000.

2. **Responsibility.** The Contractor shall designate a responsible member of its organization at the site whose duty shall be the prevention of accidents. This person shall be the Contractor's superintendent unless otherwise designated by the Contractor in writing to the Contracting Officer.

3. **Safeguards, Signs.** The Contractor shall erect and maintain, as required by existing conditions and performance of the contract, reasonable safeguards for safety and protection, including posting danger signs and other warnings against hazards, promulgating safety regulations and notifying owners and users of adjacent sites and utilities.

4. **No Loading.** The Contractor shall not load or permit any part of the construction or site to be loaded so as to endanger its safety.

5. **Emergency.** In an emergency affecting safety of persons or property, the Contractor shall act, at its discretion, to prevent threatened damage, injury or loss. The Contractor shall notify the Contracting Officer in writing of such emergency and remedial steps taken as soon as reasonably feasible. Additional compensation or extension of time claimed by the Contractor on account of an emergency may be considered by the Department.

K. **Non-compliance**

The Contracting Officer will notify the contractor of any non-compliance with the foregoing provisions and the action to be taken. If the contractor fails or refuses to comply promptly, the Contracting Officer, with the approval of the Contracting Officer, may issue an order stopping all or part of the work until satisfactory corrective action has been taken. No extension of time or payment for excess costs or damage shall be made for the time lost due to such stop action.

If no corrective action is taken by the contractor within forty-eight (48) hours after a suspension is ordered by the Contracting Officer, the Department reserves the right to take whatever action is necessary to correct the situation and to deduct all costs incurred by the Department in taking such action from moneys due the contractor.

The Contracting Officer may also suspend any operations which he or she feels are creating pollution problems although they may not be in violation of the above-mentioned requirements. In this instance, the work shall be done by Force Account as described in Modification and Force Account provisions herein. The count of

elapsed working days to be charged against the contract in this situation shall be determined by the Contracting Officer upon recommendation of the Manager.

6.29 MAINTENANCE OF SITE, CONTROL OF DUST, AND FINAL CLEANUP

The contractor shall maintain the site of the project in an orderly and clean condition, and shall at suitable intervals and/or at the direction of the Manager, remove accumulations of rubbish or refuse materials, surplus Waterworks materials, concrete mortar, excavated materials and drill cuttings not required or suitable for backfill. Chlorinated water shall not be deposited in the drainage or sewer system of the County of Kaua'i. The contractor shall keep the site, inclusive of vehicular and pedestrian traffic routes through the site, free of dirt, and dust by periodic blading, power brooming, watering or other approve means to the satisfaction of the Manager.

Upon completion and before final acceptance of the work performed under the contract, the contractor shall remove excavated materials, drill cuttings, rubbish, surplus or discarded Waterworks materials, false work, forms, temporary structures, field offices, project signs, signs not a part of the project, and his or her equipment and machinery, and shall leave the site and ground occupied by him in connection with the performance of the contract in an orderly and clean condition. Waterworks facilities constructed, altered, or worked in by the contractor in the performance of the contract shall be left "broom clean," and stains and other blemishes resulting from his or her operations, such as dropped or splattered concrete or mortar and paints, grease or oil, shall be removed from floors, walls, ceiling, windows, Waterworks equipment, pipes, instruments and all other exposed surfaces. All applicable items in section 6.28 shall be completed during final cleanup within the project area. Failure to do so will be grounds for denying final acceptance of the project work and withholding final payment.

6.30 RESPONSIBILITY OF THE CONTRACTOR PRIOR TO ACCEPTANCE

The contractor shall repair, reconstruct, restore and replace the work or any part thereof which is injured or damaged, whatever cause, prior to acceptance of the work by the Manager.

Use by the public without permission of the Department shall not in any way be construed as an acceptance of the work under the contract and shall not in any way relieve the contractor from his or her obligation under the contract. Use of parts of the project completed under the contract by the public with the approval of the Department shall constitute acceptance of such portion of such work by the Department but shall in no way be construed to relieve the Contractor from his or her remaining obligations under the contract and shall in no way be construed as final acceptance of the project as a whole. Use of parts of the project shall not prevent accrual of liquidated damages as laid out in the contract.

Final inspection will be given when all items laid out in the plans, specifications, addendum, punch list and any and all other contract documents are completed. If the Department provides the Contractor with a pre-final punch list of items, final inspection approval will not be given until those items are completed to the satisfaction of the Department. If applicable, failure to attain final approval and/or final acceptance of the

project will result in the accrual of liquidated damages.

All completed facilities that are damaged by the contractor or by his or her negligence to safeguard the facilities from construction activities shall be repaired by the contractor to the satisfaction of the Department or applicable agencies.

In case of suspension in the performance of the work under the contract from any cause whatsoever, the contractor in addition to being responsible for performing the work under the contract shall:

- A. Defend indemnify and save the Department and its officers and employees harmless from liability for any injury or damage occurring during the period that the performance of the contract is suspended.
- B. Be responsible for all materials and equipment delivered to the site of the project, including materials and equipment for which he or she has received partial payment.
- C. Properly store the materials and equipment which have been partially paid for by the Department or which have been furnished by the Department.
- D. Remove immediately as directed by the Contracting Officer all surplus materials, equipment and rubbish.
- E. Neatly and compactly store, only with the approval of the Contracting Officer, all materials and equipment on the site of projects that are not within public highways or streets.
- F. Provide suitable drainage and erect such temporary structures as are necessary to protect the project or parts of the project from damage, and damages to the Department personnel and public.

6.31 FINAL INSPECTION

The Contracting Officer shall make final inspection with representatives of other County or State agencies interested in the contract within seven (7) calendar days after the work performed under the contract is completed and the site of such work has been cleaned as provided in subsections 6.29 and 6.30. The completed project as-built plans shall contain items required in Exhibit M and shall be submitted to the Contracting Officer at the time of final inspection.

6.32 FINAL COMPLETION AND FINAL ACCEPTANCE

Final Completion is defined as when the work is fully completed and in accordance with the Contract Documents, including, without limitation, satisfaction of all punch list items.

In order to obtain a determination of Final Completion, Contractor shall notify the Contracting Officer in writing when the project is complete with no deficiencies and ready for Final Inspection.

Final inspection will be given when all items laid out in the plans, specifications, addendum, punch list and any and all other contract documents are completed. If the Contracting Officer provides the Contractor with a pre-final punch list(s) of items, Final Inspection will not be given until those items are completed to the satisfaction of the Contracting Officer. Final Inspection will be completed in accordance with section 6.31 above.

Final Acceptance is defined as obtaining a designation of Final Completion of the Work and submittal of all necessary documents, including where applicable, but not limited to the following:

1. All written warranties required by the contract.
2. All required "As-Built" drawings.
3. Complete weekly payrolls for both the General and Subcontractors.
4. Certificate of all applicable building permit inspections.
5. Final Report for Specialty Inspections.
6. Certificate of building occupancy as required.
7. Certificate of Soil and Wood Treatments.
8. Certificate of Water System Chlorination.
9. Certificate of Elevator Inspection, Boiler and Pressure Pipe installation.
10. Maintenance Service Contract and two (2) copies of a list of all equipment installed.
11. All operating and maintenance manuals for installed equipment and all associate training to be complete.
12. All other documents required by the Contract.

The Final Acceptance Date shall determine:

1. End of Contract time.
2. Commencement of all warranty periods.
3. Commencement of all maintenance services required in per the Contract.

Failure to attain Final Acceptance of the project will result in the accrual of liquidated damages in accordance with the Contract Documents.

Upon determination of Final Completion, the Contracting Officer will send written notification to the Contractor of the Final Acceptance Date via a Final Inspection of Water Facilities approval letter.

6.33 GUARANTEE OF WORK

- A. All work shall be guaranteed by the Contractor against defects resulting from the use of defective or inferior materials, equipment or workmanship for one year or as otherwise noted in the technical specifications from the date of Final Acceptance of the contract.
- B. If, within any guarantee period, repairs or changes are required in connection with the guaranteed work, which in the opinion of the OIC is rendered necessary as a result of the use of materials, equipment or workmanship which are inferior, defective or not in accordance with the terms of the contract, the Contractor shall within five (5) consecutive working days and without expense to the County commence to:
 - 1. Place in satisfactory condition in every instance all of such guarantee work and correct all defects therein; and
 - 2. Make good all damages to the building or work or equipment or contents thereof.
- C. Whenever a warranty on any product hereinafter specified exceeds one (1) year, this warranty shall become part of this contract thereof. The Contractor shall complete the warranty forms in the name of the County and submit such forms to the manufacturer within such time required to validate the warranty.

6.34 CLOSING CONTRACTS

In order to close a contract, the Contractor shall submit the final payment request and the applicable closing documents by the specified time. In the event that the Contractor should fail to comply with this request, the Contracting Officer may terminate the Contract. The pertinent provisions of **Section 8 REMEDIES** shall be applicable.

SECTION 7 - PAYMENT

7.1 PAYMENT

The contractor shall receive and accept the compensation provided in the contract as full payment for the performance of the contract.

For lump sum contracts, the contract price shall be the result obtained by first reducing the amount designated as the total sum bid or proposal in the award by the amount included therein for allowances and contingencies and adding thereto or deducting therefrom any extra cost or any reduction in cost, respectively, to the Department as a result of supplemental agreements in writing and written orders of the Contracting Officer pursuant to subsection 5.3.

For unit price contracts, the contract price shall be the sum results obtained by multiplying the number of units of such item(s) incorporated in the work under the contract by the unit price therefor. The unit price of an item shall be the amount therefor specified in the bid or proposal, provided that if the number of units of any item needed to perform the required work exceeds or is less than the number specified in the bid or proposal as the Department's estimate of quantity of units required by more than fifteen percent (15%), then a price adjustment shall be made in the unit price for the item by supplemental agreement or, at the option of the Contracting Officer, by first determining the cost of the item on the basis of a Force Account pursuant to subsection 7.4 and dividing the cost by the number of units of the item needed to perform the required work. (Auth: 3-125-10, HAR)

7.2 VARIATIONS IN ESTIMATED QUANTITIES

The quantities of the items in the offer form are approximate only, and the Department reserves the right to increase or decrease any of the quantities as the Contracting Officer shall deem necessary or advisable.

A. **Variations Requiring Adjustments.**

Where the quantity of a pay item in this contract is an estimated quantity and where the actual quantity of such pay item varies more than fifteen percent (15%) above or below the estimated quantity stated in this contract, an adjustment in the contract price shall be made upon demand of either party. The adjustment shall be based upon any increase or decrease in costs due solely to the variation above one-hundred fifteen percent (115%) or below eighty-five percent (85%) of the estimated quantity. If the quantity variation is such as to cause an increase in the time necessary for completion, the Contracting Officer shall, upon receipt of a timely written request for an extension of time, prior to the date of final settlement of the contract, ascertain the facts and make such adjustment for extending the completion date as in the judgment of the Contracting Officer the findings justify.

B. **Adjustment in Price.**

Any adjustment in contract price made pursuant to the paragraph immediately above shall be determined according to the price adjustment clause of this contract. (Auth: 3-125-10, HAR)

7.3 QUANTITIES AND MEASUREMENTS

All quantities of work to be completed under the contract shall be measured by the Contracting Officer. The contractor shall inform the Contracting Officer when measurements are required. These measurements shall be considered correct and final unless the contractor files a written protest demonstrating the existence of an error within ten (10) calendar days after receipt of such measurement data.

Quantities or measurements indicated in the bid or proposal, if any are given for the convenience of the contractor. It will be assumed that the lump sum bid or proposal and unit prices made by the contractor and the price agreed upon by him are based on a thorough knowledge of the existing conditions and the amount and kind of work to be performed. It is expressly understood and agreed by the contractor that quantities and measurements of the work to be done and the materials to be furnished under this contract which have been estimated, as given are approximate. The contractor further agrees and hereby understands that neither the Manager, Contracting Officer, the Department nor any of their representatives is to be held responsible if such estimated quantities and measurements shall not be found to be the same or even close to the actual quantities and measurements required for the work under the contract. The contractor will make no claim for anticipated profits, or for loss of profits because of a difference between the quantities or measurements of the work actually done, or of materials actually delivered, and the estimated quantities or measurements stated in the bid or proposal. If an error, omission or mis-statement shall be discovered in the quantities or measurements stated in the bid or proposal, the same shall not vitiate the contract, or release the contractor or his or her surety or sureties from performing the contract, or affect the price agreed to under the contract, or excuse the contractor from any of the obligations or liabilities under the contract, or entitle him to damages or compensation, except as provided herein.

7.4 FORCE ACCOUNT

In Force Account, the Department will pay for work done according to the following items:

A. **Labor.**

The contractor will receive the wage rate including fringe benefits for actual work engaged by the worker. Fringe benefits are the required amounts by collective bargaining agreement or other employment contract generally applicable to the classes of labor employed. The contractor shall submit the fringe benefits for each class in writing to the Manager for acceptance before the Force Account work begins. The contractor may include foremen when authorized by the Manager.

The Department will pay the contractor an amount equal to thirty-five percent (35%) of the actual labor cost to cover the contractor's and subcontractor's operating expense, indirect and direct overhead and profit.

The Manager will not allow for overtime compensation without the written acceptance of the Manager before performance of that work. For authorized overtime, the Manager will pay one and a half (1-1/2) times the hourly wage rate plus the actual hours of overtime for fringe benefits, and/or as required by collective bargaining agreement.

B. **Insurance and Tax.**

The contractor will receive the projected average rate for the required insurance and taxes including property damage, liability, worker's compensation insurance premiums, State unemployment contributions, Federal unemployment taxes and social security taxes, average tax rate and Medicare taxes. The Manager will add six percent (6%) to the insurance and tax.

The contractor shall submit the projected average rate for taxes and insurance premium for the applicable current year for acceptance by the Manager.

C. **Material.**

The contractor shall receive the actual cost of that material including transportation charges accepted by the Manager, delivered, and incorporated into the work. The Manager will add fifteen percent (15%) to the material cost to cover operating expense, direct overhead, and profit.

D. **Equipment.**

1. Machinery and equipment shall be in good working condition and suitable for the purpose for which the contractor plans to use the machinery and equipment. The Manager may reject any machinery which he or she deems unnecessary, inefficient or inadequate for the work to be performed under Force Account.

2. Individual pieces of equipment or tools having replacement value of two hundred dollars (\$200.00) or less are small tools. The Department will not make payments for small tools.

3. **Rental Rate.**

a. The Department will pay the rental rates at the per-hour rates by dividing the monthly rate for that machinery or equipment by one hundred seventy-six (176). These rental rates are in the "Rental Rate Blue Book for Construction Equipment Volume I" (Rental Blue Book). The Manager will use the edition for the period doing work. The rental rate includes the estimated operating cost per hour and the regional correction factor. The Manager shall review and accept the equipment for use.

b. If the Rental Blue Book does not have the particular type of equipment, the Manager and the contractor shall agree on the rates in writing before its use. This includes rental rates for contractor-owned trucks.

c. For trucks not owned by the contractor, the Hawai'i State Public Utilities Commission shall establish the rental rate. The Department will pay for these as a material item according to Sub-section 7.4.c.

d. The Department may allow rental rates that are higher than the "Rental Blue Book." The contractor will submit a request for such

higher rates in writing for acceptance before using such equipment.

- e. Rental rates include the cost of fuel, oil, lubricant, supplies, attachments, repairs, maintenance, tire wear, depreciation, and storage.
 - f. Rental rates for idle time.
 - i. Idle time is the time period in which the machinery and/or equipment designated for a specific Force Account work is not in use for the work. The time period shall be for a working day (8 hours).
 - ii. The Manager will pay for fifty percent (50%) of the monthly hourly rate excluding the estimated operational cost per hour per working day.
 - g. Rental rates for stand-by time.
 - i. Stand-by time is the time period in which the machinery and equipment are standing by for the specific Force Account work day. A work day shall not exceed eight (8) hours (stand-by time plus the operating time) unless the Manager authorizes the overtime.
 - ii. The Manager will pay at the monthly hourly rate including the estimated operational cost per hour per working day.
 - h. The Manager will pay for authorized overtime for each hour over the normal eight (8) hours shift work day, legal holidays, Saturdays, and Sundays.
4. The Department will only pay for hours worked. The Department will not pay for equipment due to breakdowns.
5. Less than thirty (30) minutes of operation is half (1/2) hour of operation.
6. The cost of transporting the equipment shall not exceed the rates established by PUC. If such rates are non-existent, the Manager will resolve the rates based on the rates charged by established haulers within the State.
7. Payment.
- a. Equipment on the Project Site.
 - i. The rental time shall be the time the equipment is in operation on the Force Account work. Also, the rental time includes the time required to move the equipment to the location of the Force Account and to return the equipment to the original location or to another location requiring no more

time than to return the equipment to its original location. If the contractor uses the equipment at the site of the Force Account work on other than such Force Account work, the Manager will not pay for moving time. Moving time will be paid at the monthly hourly rate including the estimated operational rate and the applicable regional correctional factor.

- ii. When moving the equipment by other than its own power, the Manager will allow loading and transporting costs instead of moving time. If the contractor uses the equipment at the site of the Force Account work on other than such Force Account work, the Manager will not pay for moving time.

Payment for the transporter, if owned by the contractor shall be on the monthly hourly rate including the estimated operational rate and the applicable regional correction factor. Payment for the transporter, if not owned by the contractor, shall be by invoice cost and paid under “material.”

The Manager will pay for the equipment at the rate of “idle time.”

b. Equipment Not on the Project Site.

- i. The Manager shall confirm the location from which the equipment is to move or transport.
- ii. If the contractor transports the equipment to the site for the exclusive use of the Force Account work, the Department will pay the cost of mobilizing and transporting the equipment from its original location to the site of the Force Account work. This includes loading and unloading. Also, the Manager will pay the cost of demobilizing and transporting the equipment back to its original location or to another location, whichever cost is less.
- iii. For self-propelled equipment, the Department will pay the cost of moving the equipment by its own power from its original location to the site of the Force Account work. Also, the Department will pay the cost of moving the equipment back to its original location or to another location, whichever cost is less.

The Manager will pay for the equipment at the monthly hourly rate including the estimated operational rate and the applicable regional correction factor.

The Manager will pay for the contractor-owned escort for the

self-propelled equipment at the monthly hourly rate including the estimated operational rate and the applicable regional correction factor. The Manager will pay for escort not owned by the contractor under material with an invoice.

- iv. If the contractor desires the return of the equipment to another location, the Department will pay the cost of transportation according to the above provisions, provided such payment does not exceed the cost of moving the equipment to the project site.
- v. If the contractor uses the equipment on the project site in ways other than on Force Account work, the Department will pay the cost of transporting the equipment to the job site. The contractor shall bear the cost of returning the equipment.
- vi. The Manager will begin the rental period at the time the equipment is unloaded at the site of work or at the time specified, whichever is later. The Manager will include each day that the machinery or equipment is at the site of the Force Account work. The rental period will terminate when the Manager orders the contractor to discontinue the use of the machinery or equipment.
- vii. If the equipment goes on stand-by because of delays in design, traffic, or other related problems uncontrollable by the contractor, the rental rate and rental period will be at the monthly hourly rate of not more than eight (8) hours per day.
- viii. If the equipment goes “idle” from the event of the previous work day, the Manager will make the rental rate and rental period under “idle time” excluding Saturdays, Sundays, and legal holidays until the Manager orders the contractor to discontinue or demobilize the machinery or equipment.

E. **Subcontracting.**

The contractor shall receive an additional amount equal to five percent (5%) of the total cost of that work computed as set forth above when the accepted subcontractors work on a Force Account basis.

F. **Bond.**

The Manager will add a bond allowance of one percent (1%) to the total sum determined in (A) through (E).

G. **State Excise Tax.**

The Manager will add a State Excise Tax (4.166%) to the total sum determined in (A) through (F) as stated in HRS 237.

The contractor shall consider the compensation as determined in (A), (B), (C), (D),

(E), (F), and (G) above to be payment in full for work done on a Force Account basis, including superintendence, overhead, use of non-rental tools and equipment, profit, taxes and subcontracting.

H. **Records.**

The authorized representative of the contractor and the authorized representative of the Manager shall verify and sign the Force Account worksheet each day for work done on a Force Account basis. These records shall be the basis for payment of the Force Account work.

I. **Statements.**

The Manager will not make payment for work done on a Force Account basis until the contractor submits duplicate, itemized statements of the cost of that Force Account work, as authorized by the Manager, and:

1. Title. Contract number, its name or with the subcontractor's name, date, project title, contract change order number, project number, item number and item description.
2. Labor. Name of worker, classification, quantity of workers, daily hours, unit, rate of pay, extension of each worker, the fringe benefits amount payable if there are fringe benefits, and the extension for its operating expense, overhead and profit.
3. Insurance Rate - Average Tax. Cost for property damage, liability, workmen's compensation insurance premiums, average tax rate of State unemployment contributions, Federal unemployment taxes and social security taxes.
4. Materials. Description of the material, quantity of material, prices, extensions, cost of transporting materials, wholesale tax, and the extension for its operating expense, overhead, and profit. Include the cost of transporting materials only if the prices of the materials do not reflect that cost.
5. Equipment. Equipment classification, quantity of equipment, daily hours, unit, rental rate, extension for each unit of machinery and equipment.
6. The contractor shall type or write the description of work done for the day. The contractor shall have an authorized representative sign the two (2) copies. The authorized representative will initial the copies if the signatures are from a copy machine.

The contractor shall accompany and support the statements by invoices for transportation charges and materials used. If materials used on the Force Account work are not specifically purchased for such work but the contractor took the material from its stock, the Manager may request verification of material payment instead of invoices. The contractor shall submit an affidavit certifying that:

- a. The contractor took such materials from his or her stock,
 - b. The contractor used the quantity claimed used, and
 - c. The price and transportation claimed represent the actual cost.
7. The Manager may make payments of the Force Account work individually by labor, materials and equipment with the compliance of each item.

7.5 PAYMENTS DURING PERFORMANCE OF WORK

The Contracting Officer, prior to the commencement of work under the contract will submit to the Contractor a schedule of values of the various parts of the work, including quantities, aggregating the total sum of the contract, made out in such form as the Contracting Officer and the contractor may agree upon, and, if required, supported by such evidence as to its correctness as the Contracting Officer, may direct. The schedule, as approved by the Contracting Officer, shall be used as a basis for payment under the contract.

The Contractor shall, not later than the last day of each month during the performance of the contract, make an estimate of the amount of work done in accordance with the contract during that month, deducting sufficient allowance for incomplete or unprotected work or to provide for any contingency for known defects or known damage to said work or for the necessity of performing any part of the work over again to cure such defects or damage.

The Department will retain five percent (5%) of the amount due under the contract to the contractor to insure the proper performance of the contract. After fifty percent (50%) of the contract is completed and progress of work is satisfactory, no additional sums for retainage shall be withheld. However, if progress of work is not satisfactory, the Department may continue to withhold as retainage, sums not exceeding five percent (5%) of the amount due the contractor. The Department will hold the retainage amount until completion, in an acceptable manner of all the work as indicated in the Plans and Specifications. The monthly estimate as ascertained hereinabove, less the retainage and previous payments, will be certified and paid to the contractor. The monthly estimates must be accompanied by an updated full performance schedule per section 6.2 and Hawai'i Residency Act 103B Compliance Form.

7.6 PAYMENT FOR DELIVERED MATERIALS

Unless the contractor submits a paid invoice for the materials, the Department will not make payment for materials under this subsection.

The Department may pay the contractor:

- A. The cost of accepted material to be incorporated in the work, and
- B. When the contractor delivers such materials to the project and stored in acceptable storage places near the project.

Also, the Department may pay the contractor:

- A. For cost of accepted materials furnished and acceptably stored in a fabricator's yard provided such storage yard is on Kaua'i and
- B. If the contractor furnishes evidence that the materials are for use on the project. The contractor shall not use that material elsewhere.

The Department will not exceed the bid or proposal price of that item for payments authorized in this subsection. The contractor shall not consider payment of the material as final acceptance. The contractor shall be responsible for those materials.

Payment for material does not relieve the contractor of his or her obligations to furnish material acceptable to the Manager and to incorporate properly the material into the project according to the contract.

The Department will not make material payment on living or perishable plant material.

7.7 FINAL INSPECTION - FINAL PAYMENT

After completion of all the work required under the contract and Final Acceptance, as defined in Section 6.32 thereof by the Contracting Officer, the contractor will be paid the balance due in accordance with the Manager's final estimate of the construction actually performed, provided that final payment will be made only with the approval of the Contracting Officer, and the written consent to the surety or sureties on the contractor's bond after receipt of a Tax Clearance certificate from the Director of Taxation of the State of Hawai'i and Internal Revenue Service as provided in Section 103-53, HRS, as amended, and certification from the Department that any and all outstanding bills of the Contractor and subcontractors due and owing to the Department are paid.

7.8 PROMPT PAYMENT BY CONTRACTORS TO SUBCONTRACTORS

- A. Prompt Payment Clause
 1. **Generally.** Any money paid to a contractor shall be disbursed to subcontractors within ten (10) days after receipt of the money in accordance with the terms of the subcontract; provided that the subcontractor has met all the terms and conditions of the subcontract and there are no bona fide disputes on which the procurement agency has withheld payment.
 2. **Final payment.** Upon final payment to the contractor, full payment to the subcontractor, including retainage, shall be made within ten days after receipt of the money; provided that there are no bona fide disputes over the subcontractor's performance under the subcontract.
 3. **Penalty.** The Contracting Officer or the contractor, as applicable, will be subject to a penalty of one and one-half percent (1.5%) per month upon outstanding amounts due that were not timely paid by the responsible

party under the following conditions. Where a subcontractor has provided evidence to the contractor of satisfactorily completing all work under their subcontract and has provided a properly documented final payment request as described in paragraph (4) herein, and:

- a. Has provided to the contractor an acceptable performance and payment bond for the project executed by a surety company authorized to do business in the State, as provided in section 103-32.1, HRS; or
 - b. The following has occurred:
 - i. A period of ninety (90) days after the day on which the last of the labor was done or performed and the last of the material was furnished or supplied has elapsed without written notice of a claim given to contractor and the surety, as provided for in section 103D-324, HRS; and
 - ii. The subcontractor has provided to the contractor, an acceptable release of retainage bond, executed by a surety company authorized to do business in the State, in an amount of not more than two (2) times the amount being retained or withheld by the contractor; any other bond acceptable to the contractor; or any other form of mutually acceptable collateral, then, all sums retained or withheld from a subcontractor and otherwise due to the subcontractor for satisfactory performance under the subcontract shall be paid by the Contracting Officer to the contractor and subsequently, upon receipt from the Contracting Officer, by the contractor to the subcontractor within the applicable time periods specified in paragraph (2) herein and section 103-10, HRS. The penalty may be withheld from future payment due to the contractor, if the contractor was the responsible party. If a contractor has violated paragraph (2) herein three (3) or more times within two (2) years of the first violation, the contractor shall be referred by the Contracting Officer to the contractors license board for action under section 444-17(14), HRS.
4. A properly documented final payment request from a subcontractor, as required by paragraph (3) herein, shall include:
- a. Substantiation of the amounts requested;
 - b. A certification by the subcontractor, to the best of the subcontractor's knowledge and belief, that:

- i. The amounts requested are only for performance in accordance with the specifications, terms, and conditions of the subcontract;
 - ii. The subcontractor has made payments due to its subcontractors and suppliers from previous payments received under the subcontract and will make timely payments from the proceeds of the payment covered by the certification, in accordance with their subcontract agreements and the requirements of this section; and
 - iii. The payment request does not include any amounts that the subcontractor intends to withhold or retain from a subcontractor or supplier in accordance with the terms and conditions of their subcontract; and
- c. The submission of documentation confirming that all other terms and conditions required under the subcontract agreement have been fully satisfied.

The Contracting Officer shall return any final payment request that is defective to the contractor within seven (7) days after receipt, with a statement identifying the defect.

5. In the case of a construction contract, a payment request made by a contractor to the Contracting Officer that includes a request for sums that were withheld or retained from a subcontractor and are due to a subcontractor may not be approved under paragraph (3) herein unless the payment request includes :
- a. Substantiation of the amounts requested; and
 - b. A certification by the contractor, to the best of the contractor's knowledge and belief, that:
 - i. The amounts requested are only for performance in accordance with the specifications, terms, and conditions of the contract;
 - ii. The subcontractor has made payments due to its subcontractors and suppliers from previous payments received under the contract and will make timely payments from the proceeds of the payment covered by the certification, in accordance with their subcontract agreements and the requirements of this section; and
 - iii. The payment request does not include any amounts that the contractor intends to withhold or retain from a

subcontractor or supplier in accordance with the terms and conditions of their subcontract.

The Contracting Officer shall return any final payment request that is defective to the contractor within seven (7) days after receipt, with a statement identifying the defect.

6. This section shall not be construed to impair the right of a contractor or a subcontractor at any tier to negotiate and to include in their respective subcontracts provisions that provide for additional terms and conditions that are requested to be met before the subcontractor shall be entitled to receive final payment under paragraph (3) herein; provided that any such payments withheld shall be withheld by the Contracting Officer. (HAR 3-125-23)

SECTION 8 - REMEDIES

8.1 DISPUTES

- A. The resolution of controversies or claims, by mutual agreement, in excess of \$50,000 shall be subject to prior written approval of the Manager. (HAR 3-126-27)
- B. All controversies between the Department and the contractor not exceeding \$50,000 which arise under, or are by virtue of, this contract and which are not resolved by mutual agreement, shall be decided by the Manager in writing, within ninety (90) calendar days after a written request by the contractor for a final decision concerning the controversy. For claims exceeding \$50,000, a decision will be issued ninety (90) calendar days after receipt of a written claim; provided that if a decision is not issued within ninety (90) calendar days, the Manager will notify the Contractor of the time within which such decision will be made. This additional time period will depend on the size and complexity of the claim and the adequacy of the Contractor's supporting data and other relevant factors. If the Manager does not issue a written decision within the specified time period, then the contractor may proceed as if an adverse decision has been received.
- C. All controversies involving claims asserted by the Department against the contractor which cannot be resolved by mutual agreement shall be the subject of a decision by the Manager.

The Manager shall immediately furnish a copy of the decision to the contractor, by certified mail, return receipt requested, or by any other method that provides evidence of receipt.

- D. Any such decision shall be final and conclusive, unless fraudulent, or unless the contractor brings an action seeking judicial review of the decision in the Fifth Circuit Court of the State of Hawai'i within six (6) months from the date of receipt of the decision.
- E. The contractor shall comply with any decision of the Manager and proceed diligently with performance of this contract pending final resolution by the Fifth Circuit Court of the State of Hawai'i of any controversy arising under, or by virtue of, this contract, except where there has been a material breach of contract by the Department; provided that in any event the contractor shall proceed diligently with the performance of the contract where the Manager has made a written determination that continuation of work under the contract is essential to the public health and safety. (Auth: 3-126-31, HAR)
- F. If a reduction in cost or extra cost to the Department is the result of a written order of the Manager pursuant to subsection 5.3 and/or 5.4 cannot be agreed, the amount of such cost shall be determined on the basis of a Force Account pursuant to subsection 7.4.

8.2 CLAIMS BASED ON ORAL DIRECTIVES

Not more than five (5) days after receipt of the written notice from the contractor that the contractor intends to treat an oral directive as a change order (in accordance with Section 5.3 herein), the Contracting Officer shall issue a change order for the subject work if the Contracting Officer agrees that it constitutes a change. If no change order is issued in the time established, it shall be deemed a rejection of contractor's claim for a change. If the contractor objects to the Contracting Officer refusal to issue a change order, it shall file a written protest with the Manager within thirty days after delivery to the Manager of the contractor's written notice of its intention to treat the oral order as a change. In all cases, the contractor shall proceed with the work. The protest shall be determined as provided in the disputes and claims section of the contract. (Auth: 3-125-16, HAR)

8.3 DEFAULT, DELAY AND TIME EXTENSIONS

A. **Default.**

If the contractor refuses or fails to perform the work, or any separable part thereof, with such diligence as will assure its completion within the time specified in this contract, or any extension thereof, fails to complete the work within such time, or commits any other substantial breach of this contract, and further fails within seven (7) days after receipt of written notice from the Contracting Officer to commence and continue correction of the refusal or failure with diligence and promptness, the Contracting Officer may, by written notice to the contractor, declare the contractor in breach and terminate the contractor's right to proceed with the work or the part of the work as to which there has been delay or other breach of contract. In the event, the Department may take over the work and perform the same to completion, by contract or otherwise, and may take possession of, and utilize in completing the work, the materials, appliances, and plants as may be on the site of the work and necessary therefore. Whether or not the contractor's right to proceed with the work is terminated, the contractor and the contractor's sureties shall be liable for any damage to the Department resulting from the contractor's refusal or failure to complete the work within the specified time.

B. **Liquidated damages upon termination.**

If fixed and agreed liquidated damages are provided in the contract, and if the Department so terminates the contractor's right to proceed, the resulting damage will consist of the liquidated damages for the time as may be required for final completion of the work.

C. **Liquidated damages in absence of termination.**

If fixed and agreed, liquidated damages are provided in the contract, and if the Department does not terminate the contractor's right to proceed, the resulting damage will consist of such liquidated damages until the contractor's work is completed and final acceptance given by the Department per section 6.32.

D. **Time extension.**

The contractor's right to proceed shall not be so terminated nor the contractor charged with resulting damage if:

1. The delay in the completion of the work arises from causes beyond the Contractor's control such as: acts of God; acts of the public enemy; acts of the Department, County, State and any other governmental entity in either a sovereign or contractual capacity; acts of another contractor in the performance of a contract with the Department; fires; floods; epidemics; quarantine restrictions; strikes or other labor disputes; freight embargoes; unusually severe weather; delays of subcontractors due to causes similar to those set forth above; or shortage of materials; provided, however, that no extension of time will be granted for a delay caused by the failure on the part of the contractor and/or subcontractor to diligently perform his or her duties as it relates to any governmental agency in a timely manner; provided further, however, that no extension of time will be granted for a delay caused by a shortage of materials, unless the contractor furnishes to the Manager proof that the contractor has diligently made every effort to obtain such materials from all known sources, and further proof that the inability to obtain the materials when originally planned did in fact cause a delay in final completion of the entire work which could not be compensated for by revising the sequence of the contractor's operations; and
2. The contractor, within ten (10) calendar days from the beginning of any such delay (unless the Contracting Officer grants a further period of time before the date of final payment under the contract), notifies the Contracting Officer in writing of the causes of delay. The Contracting Officer shall ascertain the facts and the extent of the delay and extend the time for completing the work when, in the judgment of the Contracting Officer, the findings of fact justify such an extension.

The following is required in writing when notifying the Contracting Officer of any such delay:

- A. Justification/narrative
- B. Supporting documentation
 - i. RFI's, change orders, letters/notices
- C. Description of impact (list of affected activities)
- D. Time analysis impact to be included.

The Contracting Officer shall have twenty (20) working days to approve or deny such request.

3. Rainout days are not covered by items 1 and 2 above. All rainout days shall be requested by the contractor to the Contracting Officer on the same calendar day of the rainout. Failure by the contractor to make the request within the day of the rainout shall be grounds for denial of the rainout for that particular calendar day.

The following is required in writing when notifying the Contracting Officer of any such delay:

- A. Justification/narrative
- B. Description of impact (list of affected activities)
- C. Time analysis impact to be included.

The Contracting Officer shall have twenty (20) working days to approve or deny such request.

- E. **Any additional rights and remedies.** The rights and remedies of the Department provided in this claim are in addition to any other rights and remedies provided by law or under this contract.

8.4 SUSPENSION OF WORK

- A. The Contracting Officer may by written order, suspend the performance of the work, either in whole or in part for such periods as the Manager may deem necessary for any cause, including but not limited to:
 - 1. Weather or soil conditions considered unsuitable for prosecution of the work;
 - 2. Failure on the part of the contractor to:
 - a. Correct conditions unsafe for the general public or for the workers;
 - b. Carry out orders given by the Manager;
 - c. Perform the work in strict compliance with the provisions of the contract; or
 - d. Provide adequate supervision on the jobsite.
 - 3. Whenever a redesign that may affect the work is deemed necessary by the Contracting Officer;
 - 4. Unacceptable noise or dust arising from the construction even if it does not violate any law or regulation; or
 - 5. The convenience of the Department.
- B. Suspension of work on some but not all items of work shall be considered a “partial suspension”. Suspension of work on all items shall be considered “total suspension”. The period of suspension shall be computed from the date set out in the written order for work to cease until the date of the order for work to resume.
- C. In the event that the contractor is ordered by the Contracting Officer in writing as provided herein to suspend all work under the contract in accordance with the above paragraphs 3, 4, or 5, the contractor may be reimbursed for actual money expended towards the project during the period of suspension. No allowance will be made for anticipated profits.

- D. If the performance of all or any part of the work is, suspended, for reasons beyond the control of the contractor, an adjustment shall be made for any increase in the cost of performance of this contract (excluding profit) necessarily caused by such suspension, and the contract modified in writing accordingly. However, no adjustment shall be made under this clause for any suspension:
1. To the extent that performance would have been so suspended, delayed, or interrupted by any other cause, including the fault or negligence of the contractor; or
 2. For which an adjustment is provided for or excluded under any other provisions of the contract.
- E. Claims for adjustment. Any adjustment in contract price made pursuant to this clause shall be determined in accordance with the provisions on changes and claims for adjustment. Claims for the compensation shall be filed in writing with the Manager within thirty days after the date of the order to resume work or the claims will not be considered. Together with the claim, the contractor shall submit substantiating documents covering the entire amount shown on the claim. The Manager shall take the claim under consideration and may make such investigations as are deemed necessary. The Contracting Officer shall be the sole judge as to the equitability of the claim and the Contracting Officer's decision shall be final.
- F. No adjustment. No provision of this subsection shall entitle the contractor to any adjustments for delays due to failure of surety, for suspensions made at the request of the contractor, for any delay required under the contract, for suspensions, either partial or whole, made by the Manager under the provisions in subparagraph A2. (Auth: 3-125-7, HAR)

8.5 TERMINATION OF CONTRACT - WORK MAY BE TAKEN OVER BY DEPARTMENT

The Department may terminate the contract, or require the work therein to be completed by the surety or sureties under the contractor's bond or take over such work as hereinafter provided without terminating the contract, if the contractor:

- A. fails to begin work under the contract at the time required,
- B. is unnecessarily delaying the performance of the contract or any part thereof,
- C. is failing to perform the contract with sufficient or adequate workmen, equipment or materials or is not making sufficient progress to ensure the completion of the contract within the time specified,
- D. fails to perform the contract in accordance with directions of the Manager,
- E. discontinues performance of the contract,

- F. fails to re-commence performance of the contract within a reasonable time after service of a written order to do so if the performance had been suspended,
- G. becomes insolvent or is declared bankrupt,
- H. commits any act of bankruptcy or insolvency,
- I. allows any final judgment to stand against him unsatisfied for a period of ten (10) days,
- J. makes an assignment for the benefit of creditors,
- K. fails to pay for all labor, tools, materials, and equipment,
- L. has been or is paying wages to any laborer or mechanic employed on the job site at a rate below the minimum rate specified in the contract,
- M. has failed to pay full compensation for overtime work by any such laborer or mechanic,
- N. has abandoned the performance of the contract,
- O. has made unjustifiable and substantive changes from the condition set forth in his or her original itemized bid or proposal,
- P. or violates or fails to perform the contract in accordance with the terms, covenants, conditions, provisions and intent thereof.

Whenever the Contracting Officer is not satisfied with the performance of the contract the Contracting Officer, with the approval of the Contracting Officer, may make specified orders as to the progress or conduct of such work, giving the contractor a definite period within which to comply with such orders; or whenever the contractor shall be in default in any particular requirement, the Contracting Officer, with the approval of the Contracting Officer Manager, shall serve the contractor, or its authorized representatives, with a written notice to remedy said default or any part thereof within fourteen (14) calendar days after notice thereof, serving copies of such notice to the surety or sureties of the contractor, as the case may be. If, after the expiration of the time of such notice, the contractor fails to comply with the notice, or the default continues, the Contracting Officer, with the approval of the Contracting Officer Manager, may order all payment under the contract to cease and the work to be discontinued. Upon such order the contractor shall discontinue the work. Failure on the part of the Department to order a discontinuance of the work or payment for the same shall in no event be construed as an acceptance of the work, nor as a waiver of any failure or any default. (Auth: 3-125-16, HAR [generally]).

Immediately upon or after ordering the contractor to discontinue the work, the Contracting Officer Manager may require the completion of the contract by the surety or sureties upon the contractor's bond, or (without prejudice to the Department to rely upon said bond), the Department's contract to a second contractor or contractors, or may direct DOW employees to enter upon the work and to use such materials, tools and equipment as he or she may find

upon the work and to procure labor, additional tools, materials and equipment for the completion of the work, and to complete said work in such a manner as he or she may deem advisable, and in such event the cost or expenses of completing the work and the delay resulting therefrom shall be a charge against the contractor and/or surety or sureties.

8.6 TERMINATION FOR CONVENIENCE

- A. Terminations. In addition to any other reason specified in subsection 8.5 above, the Contracting Officer may, with approval of the Manager, when the interests of the Department so require, terminate this contract in whole or in part, for the convenience of the Department. The Contracting Officer shall give written notice of the termination to the contractor specifying the part of the contract terminated and when termination becomes effective.
- B. Contractor's obligations. The contractor shall incur no further obligations in connection with the terminated work and on the date set in the notice of termination the contractor will stop work to the extent specified. The contractor shall also terminate outstanding orders and subcontracts as they relate to the terminated work. The contractor shall settle the liabilities and claims arising out of the termination of subcontracts and orders connected with the terminated work subject to the Department's approval. The Contracting Officer, upon recommendation by the Manager, may direct the contractor to assign the contractor's right, title, and interest under terminated orders or subcontracts to the Department. The contractor must still complete the work not terminated by the notice of termination and may incur obligations as necessary to do so.
- C. Right to construction and goods. The Contracting Officer may, upon recommendation by the Manager, require the contractor to transfer title and deliver to the Department in the manner and to the extent directed by the Contracting Officer:
1. Any completed constructions; and
 2. The partially completed construction, books, materials, parts, tools, dies, jigs, fixtures, plans, drawings, information, and contract rights (hereinafter called "construction material") as the contractor has specifically produced or specially acquired for the performance of the terminated part of this contract.

The contractor shall protect and preserve property in the possession of the contractor in which the Department has an interest. If the Contracting Officer does not exercise this right, the contractor shall use best efforts to sell the construction, goods, and construction materials in accordance with the standards of section 490:2-706, HRS. This in no way implies that the Department has breached the contract by exercise of the termination for convenience clause.

- D. Compensation.
1. The contractor shall submit a termination claim specifying the amounts due because of the termination for convenience together with cost or pricing data, submitted to the extent required by subchapter 15, chapter 3-122, HAR,

bearing on such claim. If the contractor fails to file a termination claim within one (1) year from the effective date of termination, the Contracting Officer, upon recommendation of the Manager, may pay the contractor, if at all, an amount set in accordance with subparagraph 8.6D3(b) of this subsection.

2. The Contracting Officer, upon recommendation of the Manager, and the contractor may agree to a settlement provided the contractor has filed a termination claim supported by cost or pricing data submitted as required and that the settlement does not exceed the total contract price plus settlement costs reduced by payments previously made by the Department, the proceeds of any sales of construction, goods, and construction materials under subparagraph 8.6D3(c), and the contract price of the work not terminated.
3. Absent complete agreement under paragraph 8.6D2 of this subsection, the Contracting Officer, upon notice from the Manager, shall pay the contractor the following amounts, provided payments under paragraph 8.6D2 of this subsection shall not duplicate payments under this paragraph the total (without duplication of any items) of:
 - a. The cost of all contract work performed prior to the effective date of the notice of termination work plus a five percent (5%) markup on actual direct costs on the portion of the work (the markup shall not include anticipatory profit or consequential damages) less amounts paid or to be paid for completed portions of the work; provided, however, that if it appears that the contractor would have sustained a loss if the entire contract would have been completed, no markup shall be allowed or included and the amount of compensation shall be reduced to reflect the anticipated rate of loss;
 - b. Subject to the prior approval of the Contracting Officer, the costs of settling and paying claims arising out of the termination of subcontracts or orders pursuant to “contractor’s obligations” provisions of this contract. Subcontractors shall be entitled to a markup of no more than ten percent (10%) on direct costs incurred to the date of termination.

These costs must not include costs paid in accordance with clause 8.6D3a.;
 - c. The total sum to be paid the contractor under this paragraph shall not exceed the total contract price reduced by the amount of any sales of construction, goods, and construction materials under subsection 8.3C, and the contract price of work not terminated.
4. Cost claimed, agreed to, or established under paragraphs 8.3D2 and 8.3D3 of this subsection shall be in accordance with chapter 3-123, HAR

8.7 COSTS OF COMPLETING CONTRACT

The contractor and/or his or her surety or sureties shall pay the Department for all costs incurred to complete the work under the contract if the Department takes the work out of the hands of the contractor pursuant to the provisions of Subsection 8.5, and for damages for any delay in the performance of the contract.

8.8 DAMAGES FOR DELAY

A. Liquidated Damages.

The amount of damage to the Department as a result of failure to complete the work under the contract within the time fixed or any extension thereof, exclusive of overhead expenses, being certain but difficult, if not impossible, to ascertain, the contractor agrees to pay the sum stated in the contract as liquidated damages, and not by way of penalty, for every day of delay until the work under the contract is completed and accepted, or a reasonable time has expired for completion and acceptance of the portion of the contract remaining to be performed if the Department takes the work under the contract out of the hands of the contractor.

8.9 DAMAGES FOR EXTRA EXPENSES IMPOSED ON DEPARTMENT

The contractor shall pay the Department for all the expenses incurred in re-doing any of the Department's obligations under the contract due to any actions or conduct of the contractor, including the replacing of marks or stakes set by the Manager.

8.10 DEFECTIVE WORK

Any defective work, workmanship or materials that may be discovered in the performance of the contract before its acceptance or within one (1) year thereafter as provided in the performance bond, shall be replaced by the contractor with work and materials that conform to the contract at no cost or expense to the Department. The fact that the Manager may have overlooked defective work during the performance of the contract shall not constitute the acceptance of the same. No payment, whether partial or final, shall be construed to be an acceptance of any defective work, workmanship or materials in the work performed under the contract.

The Contracting Officer may at any time, stop the performance of the contract or any portion thereof which is not being done in accordance with a contract by written order. Such order shall not in any way relieve the contractor from performing the contract and shall not in any way terminate, cancel or abrogate the contract or any part thereof; and the Department shall not in any way be responsible for the delay due to stopping the performance of the contract or any portion thereof as aforesaid.

The Contractor shall provide a warranty on the project work for one year after final inspection date as reflected in the final inspection letter.

8.11 UNAUTHORIZED PERFORMANCE

Performance of any work beyond the lines and grades shown on the plans or established by

the Contracting Officer or performance of any extra work without written order will be considered as unauthorized and will not be paid for. The Contracting Officer may require the removal of such work by service of a written order upon the contractor. If the contractor fails to comply promptly with such order, the Department shall remove such work and the contractor shall pay the Department for all expenses incurred in the removal of such work.

8.12 AUTHORITY TO WITHHOLD MONEY DUE OR PAYABLE

The Department may withhold such amounts from the money due or to become payable under the contract to the contractor, or any assignee under subsection 5.6, as may be necessary to:

- A. Protect the Department from any liability resulting from the work performed under this contract;
- B. Satisfy any obligation of the contractor or its subcontractors to the Department, including obligations not relating to the contract, and the obligation of the contractor to the workmen, subcontractors, and materialmen who have performed labor or furnished material and equipment under the contract as provided by law; and
- C. Repair, restore, or compensate for, any real or personal property located within the project site or in the vicinity thereof which has been damaged as a result of the fault or negligence of the contractor while performing the work under this contract; provided that the estimated amount of damages for each separate property shall not be in excess of five hundred dollars (\$500.00).

The Department may make such payments from such amounts withheld as may be necessary to cause the repair or restoration of the damaged properties or to compensate therefor, to discharge such obligation as provided under paragraph B above, and to protect the Department from any liability resulting from the work performed under this contract; provided, however, before making any payment for damages to property prescribed in paragraph C above, the Department through the Manager shall request the contractor in writing to undertake the repair or restoration of the damaged property or make compensation therefor. If the contractor fails or refuses to make such repair, restoration or compensation to the satisfaction of the Manager within thirty (30) calendar days after such notification, the Department may make the necessary payments.

8.13 SPECIAL EMERGENCY TERMINATION

In the event of a finding by the Manager and approved by the Contracting Officer that a national emergency exists which creates a shortage of materials, labor, or equipment and that such emergency will probably continue to exist for an indefinite length of time, or that funds are no longer available to the Department by reason of which the contractor will be unable to perform the work under the contract, the Department may cancel all remaining work required to be performed under the contract by written order.

Upon such cancellation, the Department shall pay the contractor the amount hereinafter provided. For lump sum contracts, an agreed upon price for the performance of the contract up to the time of cancellation, or at the option of the Manager, a price for such performance

determined on the basis of a Force Account pursuant to subsection 7.4. For unit price contracts, the sum of the results obtained by multiplying the number of units of each item incorporated into the parts of the project performed under the contract up to the time of cancellation by the unit price therefor. For both lump sum and unit price contracts, the contractor shall also be paid for such expenditures as in the judgment of the Manager are not otherwise compensated for and are require in the preparation and moving of equipment and materials to the site of the project, the intent being that an equitable settlement shall be made with the contractor. No claim for loss of anticipated profits, however, shall be made or considered.

Materials obtained by the contractor for the project, that have been inspected, tested, and accepted by the Manager, and that are not incorporated in the work under the contract, and which have been properly stored and maintained, will be purchased from the contractor at actual cost as shown by receipted bills or other proper evidence of actual cost at such points of delivery as may be designated by the Manager.

8.14 REMEDIES NOT EXCLUSIVE

The express provision herein of certain measures which may be exercised by the Department for its protection shall not be construed to preclude the Department from exercising any other or further legal or equitable right to protect its interest.

8.15 REMEDIES

Any dispute arising under or out of this solicitation or contract is subject to chapter 3-126, HAR. (Auth: 3-125-24, HAR)

APPROVED:



Manager & Chief Engineer

May 19, 2016
Date

EXHIBIT A – SURETY [BID][PROPOSAL] BOND

SURETY [BID] [PROPOSAL] BOND
(11/15/11)

Bond No. _____

KNOW TO ALL BY THESE PRESENTS:

That we,

(full name or legal title of offeror)

as Offeror, hereinafter called Principal, and

(name of bonding company)

as Surety, hereinafter called Surety, a corporation authorized to transact business as a Surety in the State of Hawai‘i, are held and firmly bound unto the Department of Water, County of Kaua‘i, as Owner, hereinafter called the Owner, in the penal sum of

(required amount of bid/proposal security)
Dollars (\$ _____), lawful money of the United States of America, for the payment of which sum well and truly to be made, the said Principal and the said Surety bind ourselves, our heirs, executors, administrators, successors and assigns, jointly and severally, firmly by these presents.

WHEREAS:

The Principal has submitted an offer for _____

(project by number and brief description)

NOW, THEREFORE:

The condition of this obligation is such that if the Department of Water, County of Kaua‘i, shall reject said offer, or in the alternate, accept the offer of the Principal and the Principal shall enter into a Contract with the Department of Water, County of Kaua‘i, in accordance with the terms of such offer, and give such bond or bonds as may be specified in the solicitation or Contract Documents with good and sufficient surety for the faithful performance of such Contract and for the prompt payment of labor and material furnished in the prosecution thereof as specified in the solicitation then this obligation shall be null and void, otherwise to remain in full force and effect.

Signed this _____ day of _____, 20____.

(Seal)

Name of Principal (Offeror)

Signature

Title
(Seal)

Name of Surety

Signature

Title

SURETY [BID] [PROPOSAL] BOND (EXHIBIT A)

EXHIBIT B – PERFORMANCE BOND (SURETY)

PERFORMANCE BOND (SURETY)

(11/15/11)

KNOW TO ALL BY THESE PRESENTS:

That

(full legal name and street address of Contractor)
as Contractor, hereinafter called the Principal, and

(name and street address of bonding company)
as Surety, hereinafter called Surety, a corporation(s) authorized to transact business as a Surety in the State of Hawai'i, are held and firmly bound unto the Department of Water, County of Kauai, its successors and assigns, hereinafter called Oblige, in the amount of

Dollars (\$ _____), to which payment Principal and Surety bind themselves, their heirs, executors, administrators, successors and assigns, jointly and severally, firmly by these presents.

WHEREAS, the above-bound Principal has signed a Contract with Oblige _____, for the following project:

hereinafter called Contract, which Contract is incorporated herein by reference and made a part hereof.

NOW, THEREFORE, the condition of this obligation is such that:

If the Principal shall promptly and faithfully perform, and fully complete the Contract in strict accordance with the terms of the Contract as said Contract may be modified or amended from time-to-time; then this obligation shall be void; otherwise to remain in full force and effect.

Surety to this Bond hereby binds and agrees that no changes, extensions of time, alterations, or additions to the terms of the Contract, including the work to be performed thereunder, and the specifications or drawings accompanying same, shall in any way affect its obligation on this bond, and it does hereby waive notice of any such changes, extensions of time, alterations, or additions, and agrees that they shall become part of the Contract.

In the event of Default by the Principal, of the obligations under the Contract, then after written Notice of Default from the Oblige to the Surety and the Principal and subject to the limitation of the penal sum of this bond, Surety shall remedy the Default, or take over the work to be performed under the Contract and complete such work, or pay moneys to the Oblige in satisfaction of the surety performance obligation on this bond.

Signed this _____ day of _____, 20____.

(Seal)

Name of Principal (Contractor)

*

Signature

Title
(Seal)

Name of Surety

*

Signature

Title

*ALL SIGNATURES MUST BE ACKNOWLEDGED
BY A NOTARY PUBLIC

PERFORMANCE BOND (SURETY) (EXHIBIT B)

EXHIBIT C - PERFORMANCE BOND

PERFORMANCE BOND (11/15/11)

KNOW TO ALL BY THESE PRESENTS:

That we,

(full legal name and street address of Contractor)
as Contractor, hereinafter called Contractor, is held and firmly bound unto the Department of Water, City of Kaua'i, its successors and assigns, as Oblige, hereinafter called Oblige, in the amount of

(dollar amount of contract)
DOLLARS (\$ _____), lawful money of the United States of America, for the payment of which to the said Oblige, well and truly to be made, Contractor binds itself, its heirs, executors, administrators, successors and assigns, firmly by these presents. Said amount is evidenced by:

- Legal tender;
- Share Certificate unconditionally assigned to or made payable at sight to _____
Description _____
- Certificate of Deposit, No. _____, dated _____, issued by _____ drawn on _____ a bank, savings institution or credit union insured by the Federal Deposit Insurance Corporation or the National Credit Union Administration, payable at sight or unconditionally assigned to _____
- Cashier's Check No. _____, dated _____, issued by _____, drawn on _____ a bank, savings institution or credit union insured by the Federal Deposit Insurance Corporation or the National Credit Union Administration, payable at sight or unconditionally assigned to _____;
- _____ Check No. _____, dated _____, issued by _____, drawn on _____ a bank, savings institution or credit union insured by the Federal Deposit Insurance Corporation or the National Credit Union Administration, payable at sight or unconditionally assigned to _____;
- Treasurer's Check No. _____, dated _____, issued by _____, drawn on _____ a bank, savings institution or credit union insured by the Federal Deposit Insurance Corporation or the National Credit Union Administration, payable at sight or unconditionally assigned to _____;
- Official Check No. _____, dated _____, issued by _____, drawn on a bank, savings institution or credit union insured by the Federal Deposit Insurance Corporation or the National Credit Union Administration, payable at sight or unconditionally assigned to _____;

PERFORMANCE BOND (EXHIBIT C)

- Certified Check No. _____, dated _____, accepted by a bank, savings institution or credit union insured by the Federal Deposit Insurance Corporation or the National Credit Union Administration, payable at sight or unconditionally assigned _____;

WHEREAS:

The Contractor has by written agreement dated _____ entered into a Contract with Obligee for the following Project:

hereinafter called Contract, which Contract is incorporated herein by reference and made a part hereof.

NOW, THEREFORE,

The condition of this obligation is such that, if Contractor shall promptly and faithfully perform the Contract in accordance with, in all respects, the stipulations, agreements, covenants and conditions of the Contract as it now exists or may be modified according to its terms, and shall deliver the Project to the Obligee, or to its successors or assigns, fully completed as in the Contract specified and free from all liens and claims and without further cost, expense or charge to the Obligee, its officers, agents, successors or assigns, free and harmless from all suits or actions of every nature and kind which may be brought for or on account of any injury or damage, direct or indirect, arising or growing out of the doing of said work or the repair or maintenance thereof or the manner of doing of the same or the neglect of the Contractor or its agents or servants or the improper performance of the Contract by the Contractor or its agents or servants or from any other cause, then this obligation shall be void; otherwise it shall be and remain in full force and effect.

AND IT IS HEREBY STIPULATED AND AGREED that suit on this bond may be brought before a court of competent jurisdiction without a jury, and that the sum or sums specified in the said Contract as liquidated damages, if any, shall be forfeited to the Obligee, its successors or assigns, in the event of a breach of any, or all, or any part of, the covenants, agreements, conditions, or stipulations contained in the Contract or in this bond or in accordance with the terms thereof.

The amount of this bond may be reduced by and to the extent of any payment or payments made in good faith hereunder.

Signed this _____ day of _____, 20_____.

(Seal)

Name of Contractor

*

Signature

Title

*ALL SIGNATURES MUST BE ACKNOWLEDGED
BY A NOTARY PUBLIC

PERFORMANCE BOND (EXHIBIT C)

EXHIBIT D – LABOR AND MATERIAL PAYMENT BOND (SURETY)
LABOR AND MATERIAL PAYMENT BOND (SURETY)

(11/15/11)

KNOW TO ALL BY THESE PRESENTS:

That _____,
(full legal name and street address of Contractor)
as Contractor, hereinafter called Principal, and

(name and street address of bonding company)
as Surety, hereinafter called Surety, a corporation(s) authorized to transact business as a Surety in the State of Hawai'i, are held and firmly bound unto the Department of Water, County of Kaua'i, its successors and assigns, hereinafter called Oblige, in the amount of _____ Dollars (\$ _____), to which payment Principal and Surety bind themselves, their heirs, executors, administrators, successors and assigns, jointly and severally, firmly by these presents.

WHEREAS, the above-bound Principal has signed a Contract as Oblige on _____
for the following
project: _____,
hereinafter called Contract, which Contract is incorporated herein by reference and made a part hereof.

NOW THEREFORE, the condition of this obligation is such that if the Principal shall promptly make payment to any Claimant, as hereinafter defined, for all labor and material supplied to the Principal for use in the performance of the Contract, then this obligation shall be void; otherwise to remain in full force and effect.

1. Surety to this Bond hereby stipulates and agrees that no changes, extensions of time, alterations, or additions to the terms of the Contract, including the work to be performed hereunder, and the specifications or drawings accompanying same, shall in any way affect its obligation on this bond, and it does hereby waive notice of any such changes, extensions of time, alterations or additions, and agrees that they shall become part of the Contract.

2. A "Claimant" shall be defined here as any person who has furnished labor or materials to the Principal for the work provided in the Contract.

Every Claimant who has not been paid amounts due for labor and materials furnished for work provided in the Contract may institute an action against the or she Principal and the Surety on this bond at the time and in the manner prescribed in Section 103D-24, Hawai'i Revised Statutes and have the rights and claims adjudicated in the action, and judgment rendered thereon; subject to the Oblige's priority on this bond. If the full amount of the liability of the Surety on this bond is insufficient to pay the full amount of the claims, then after paying the full amount due the Oblige, the remainder shall be distributed pro rata among the claimants.

Signed and sealed this _____ day of _____, 20____.
(Seal)

Name of Principal (Contractor)
*

Signature

Title
(Seal)

Name of Surety
*

Signature

Title

*ALL SIGNATURES MUST BE ACKNOWLEDGED
BY A NOTARY PUBLIC
LABOR AND MATERIAL PAYMENT BOND (SURETY) (EXHIBIT D)

EXHIBIT E - LABOR AND MATERIAL PAYMENT BOND

LABOR AND MATERIAL PAYMENT BOND (11/15/11)

KNOW TO ALL BY THESE PRESENTS:

That we,

(full legal name and street address of Contractor)

as Contractor, hereinafter called Contractor, is held and firmly bound unto the Department of Water, County of Kaua'i, its successors and assigns, as Obligee, hereinafter called Obligee, in the amount of

(dollar amount of contract)

DOLLARS (\$ _____), lawful money of the United States of America, for the payment of which to the said Obligee, well and truly to be made, Contractor binds itself, its heirs, executors, administrators, successors and assigns, firmly by these presents. Said amount is evidenced by:

- Legal tender;
- Share Certificate unconditionally assigned, payable at sight

Description _____
- Certificate of Deposit, No. _____, dated _____, issued by _____, drawn on _____, a bank, savings institution or credit union insured by the Federal Deposit Insurance Corporation or the National Credit Union Administration, payable at sight or unconditionally assigned to _____;
- Cashier's Check No. _____, dated _____, issued by _____, drawn on _____, a bank, savings institution or credit union insured by the Federal Deposit Insurance Corporation or the National Credit Union Administration, payable at sight or unconditionally assigned to _____;
- Teller's Check No. _____, dated _____, issued by _____, drawn on _____, a bank, savings institution or credit union insured by the Federal Deposit Insurance Corporation or the National Credit Union Administration, payable at sight or unconditionally assigned to _____;
- Treasurer's Check No. _____, dated _____, issued by _____, drawn on _____, a bank, savings institution or credit union insured by the Federal Deposit Insurance Corporation or the National Credit Union Administration, payable at sight or unconditionally assigned to _____;

LABOR AND MATERIAL PAYMENT BOND
(EXHIBIT E)

- Official Check No. _____, dated _____, issued by _____, drawn on a bank, savings institution or credit union insured by the Federal Deposit Insurance Corporation or the National Credit Union Administration, payable at sight or unconditionally assigned to _____;
- Certified Check No. _____, dated _____, accepted by a bank, savings institution or credit union insured by the Federal Deposit Insurance Corporation or the National Credit Union Administration, payable at sight or unconditionally assigned _____;

WHEREAS:

The Contractor has by written agreement dated _____ entered into a Contract with Obligeo for the following Project:

hereinafter called Contract, which Contract is incorporated herein by reference and made a part hereof.

NOW, THEREFORE,

The condition of this obligation is such that, if Contractor shall promptly and faithfully perform the Contract in accordance with, in all respects, the stipulations, agreements, covenants and conditions of the Contract as it now exists or may be modified according to its terms, free from all liens and claims and without further cost, expense or charge to the Obligeo, its officers, agents, successors, or assigns, free and harmless from all suits or actions of every nature and kind which may be brought for or on account of any injury or damage, direct or indirect, arising or growing out of the doing of said work or the repair or maintenance thereof or the manner of doing the same or the neglect of the Contractor or its agents or servants or the improper performance of the Contract by the Contractor or its agents or servants or from any other cause, and shall promptly pay all persons supplying labor and materials for the performance of the Contract, then this obligation shall be void; otherwise it shall be and remain in full force and effect.

AND IT IS HEREBY STIPULATED AND AGREED that suit on this bond may be brought before a court of competent jurisdiction without a jury, and that the sum or sums specified in the said Contract as liquidated damages, is any, shall be forfeited to the Obligeo, its successor or assigns, in the event of a breach of any, or all, or any part of, the covenants, agreements, conditions, or stipulations contained in the Contract or in this bond in accordance with the terms thereof.

AND IT IS HEREBY STIPULATED AND AGREED that this bond shall inure to the benefit of any and all persons entitled to file claims for labor performed or materials furnished in said work so as to give any and all such persons a right of action as contemplated by Sections 103D-324(d) and 103D-324(e), Hawai'i Revised Statutes.

The amount of this bond shall be reduced by and to the extent of any payment or payments made in good faith hereunder, inclusive of the payment of mechanics' liens which may be filed of record against the Project, whether or not claim for the amount of such lien be presented under and against this bond.

Signed this _____ day of _____, 20_____.

(Seal)

 Name of Contractor

*

 Signature

 Title

*ALL SIGNATURES MUST BE
 ACKNOWLEDGED BY A NOTARY
 PUBLIC

LABOR AND MATERIAL PAYMENT BOND (EXHIBIT E)

EXHIBIT F – PERFORMANCE BOND (SURETY) FOR SUPPLEMENTAL AGREEMENT FOR GOODS AND SERVICES

(11/15/11)

KNOW TO ALL BY THESE PRESENTS:

That

(full legal name and street address of Contractor)
as Contractor, hereinafter called Principal, and

(name and street address of bonding company)
as Surety, hereinafter called Surety, a corporation(s) authorized to transact business as a Surety in the State of Hawai'i, are held and firmly bound unto the Department of Water, County of Maui, its successors and assigns, hereinafter called Oblige, in the amount of _____ Dollars (\$ _____), to which payment Principal and Surety bind themselves, their heirs, executors, administrators, successors and assigns, jointly and severally, firmly by these presents.

WHEREAS, the above-bound Principal has entered into a contract with County of Maui, dated _____, for _____, and entered into Supplemental Agreement No. _____, dated _____, for the period hereinafter collectively called Contract, which Contract is incorporated herein by reference and made a part hereof.

NOW THEREFORE, the condition of the obligation is such that:

If the Principal shall promptly and faithfully perform, and fully complete the Contract in strict accordance with the terms of the Contract as said Contract may be modified or amended from time to time; then this obligation shall be void; otherwise to remain in full force and effect.

Surety to this Bond hereinafter stipulates and agrees that no changes, extensions of time, alterations, or additions to the terms of the Contract, including the work to be performed thereunder, and the specifications or drawings accompanying same, shall in any way affect its obligation on this bond, and it does hereby waive notice of any such changes, extensions of time, alterations or additions, and agrees that they shall become part of the Contract.

In the event of Default by the Principal, of the obligations under the Contract, then after written Notice of Default from the Oblige, the Surety and the Principal, Surety shall either remedy the Default, or take over the work to be performed under the Contract and complete such work, subject, however, to the limitation of the penal sum of this bond.

Signed _____ day of _____, 20____.

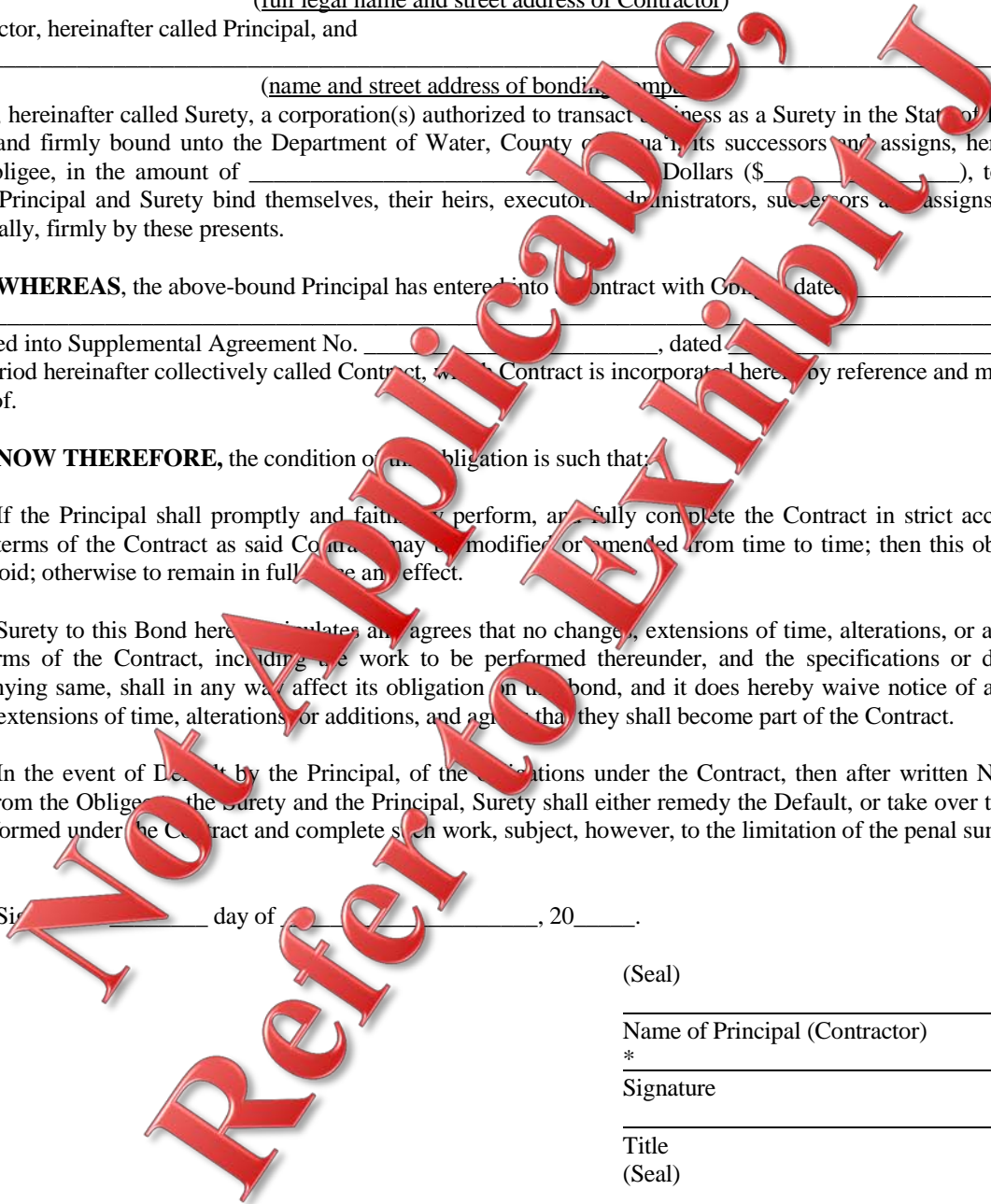

(Seal)

Name of Principal (Contractor)

*

Signature

Title
(Seal)

Name of Surety

*

Signature

Title

*ALL SIGNATURES MUST BE
ACKNOWLEDGED BY A NOTARY PUBLIC

PERFORMANCE BOND (SURETY) FOR SUPPLEMENTAL
AGREEMENT FOR GOODS AND SERVICES (EXHIBIT F)

**EXHIBIT G- PERFORMANCE BOND FOR SUPPLEMENTAL AGREEMENT
FOR GOODS AND SERVICES**

(11/15/11)

KNOW TO ALL BY THESE PRESENTS:

That we, _____,

(full legal name and street address of Contractor)

as Contractor, hereinafter called Contractor, is held and firmly bound unto the Department of Water, County of Kaua'i, its successors and assigns, as Obligee, hereinafter called Obligee, in the amount of

_____ (dollar amount of contract)

DOLLARS (\$ _____), lawful money of the United States of America for the payment of which the said Obligee, well and truly to be made, Contractor binds itself, its heirs, executors, administrators, successors and assigns, firmly by these presents. Said amount is evidenced by:

- Legal tender;
- Share Certificate unconditionally assigned to or payable at sight to _____
Description _____
- Certificate of Deposit, No. _____, dated _____
issued by _____
drawn on _____
a bank, savings institution or credit union insured by the Federal Deposit Insurance Corporation or the National Credit Union Administration, payable at sight or unconditionally assigned to _____
- Cashier's Check No. _____, dated _____,
issued by _____
drawn on _____
a bank, savings institution or credit union insured by the Federal Deposit Insurance Corporation or the National Credit Union Administration, payable at sight or unconditionally assigned to _____
- Teller's Check No. _____, dated _____,
issued by _____
drawn on _____
a bank, savings institution or credit union insured by the Federal Deposit Insurance Corporation or the National Credit Union Administration, payable at sight or unconditionally assigned to _____;
- Treasurer's Check No. _____, dated _____,
issued by _____
drawn on _____
a bank, savings institution or credit union insured by the Federal Deposit Insurance Corporation or the National Credit Union Administration, payable at sight or unconditionally assigned to _____;
- Official Check No. _____, dated _____,
issued by _____ drawn on a bank, savings institution or credit union insured by the Federal Deposit Insurance Corporation or the National Credit Union Administration, payable at sight or unconditionally assigned to _____;

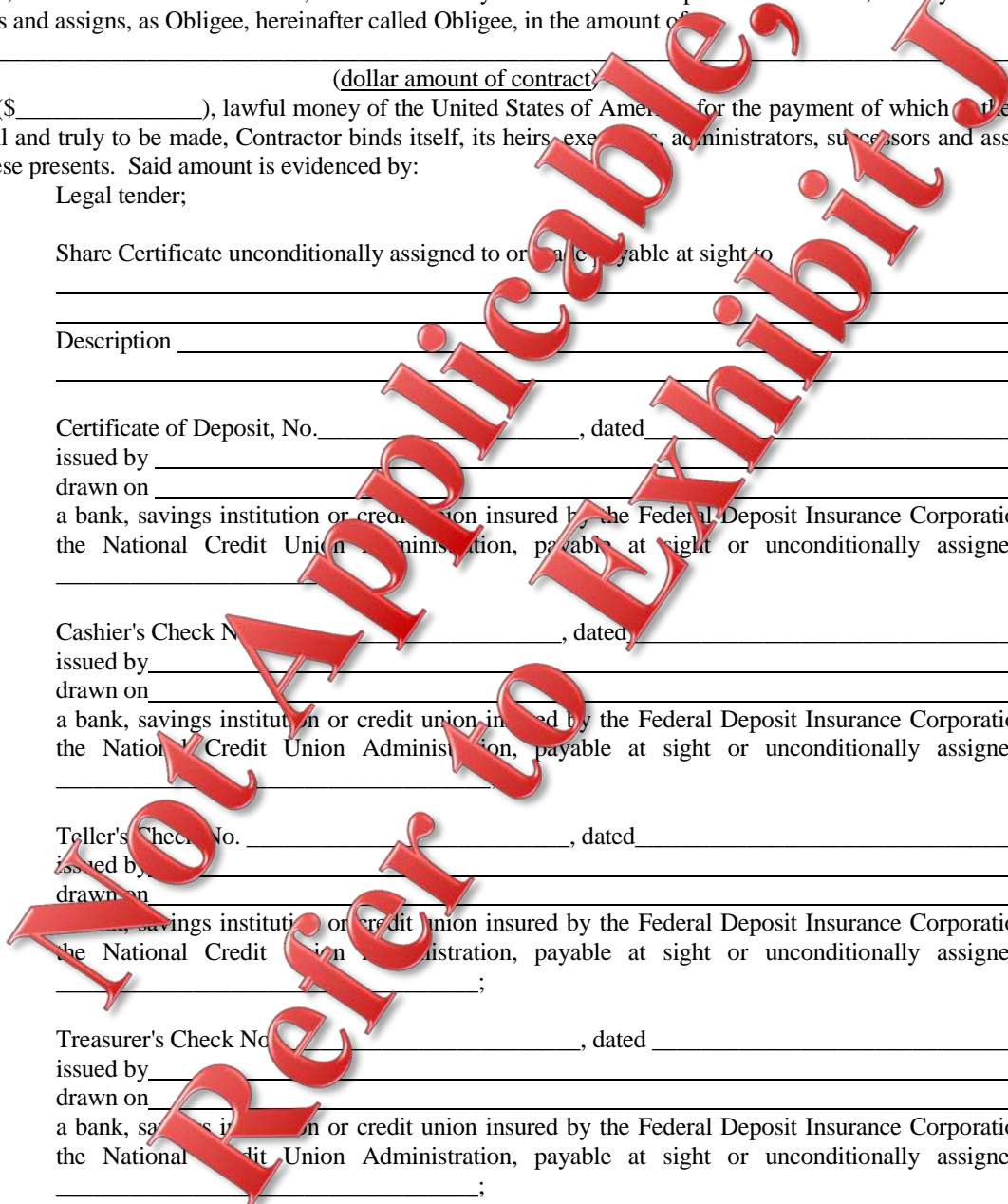

PERFORMANCE BOND
FOR SUPPLEMENTAL AGREEMENT FOR GOODS AND SERVICES (EXHIBIT G)

Certified Check No. _____, dated _____, accepted by a bank, savings institution or credit union insured by the Federal Deposit Insurance Corporation or the National Credit Union Administration, payable at sight or unconditionally assigned _____;

WHEREAS:

The Contractor has by written agreement dated _____ entered into a Contract with Obligeo for the following Project:

_____ and entered into Supplemental Agreement No. _____, dated _____ for the period _____; hereinafter collectively called Contract, which Contract is incorporated herein by reference and made a part hereof.

NOW, THEREFORE,

The condition of this obligation is such that, if Contractor shall promptly and faithfully perform the Contract in accordance with, in all respects, the stipulations, agreements, covenants and conditions of the Contract as it now exists or may be modified according to its terms, and shall deliver the Project to the Obligeo, or to its successors or assigns, fully completed as in the Contract specified and free from all liens and claims and without further cost, expense or charge to the Obligeo, its officers, agents, successors, or assigns, free and harmless from all suits or actions of every nature and kind which may be brought for or on account of any injury or damage, direct or indirect, arising or growing out of the doing of said work or the repair or maintenance thereof or the manner of doing the same or the neglect of the Contractor or its agents or servants or the improper performance of the Contract by the Contractor or its agents or servants or from any other cause, then this obligation shall be void; otherwise it shall be and remain in full force and effect.

AND IT IS HEREBY STIPULATED AND AGREED that suit on this bond may be brought before a court of competent jurisdiction without a jury, and that the sum or sums specified in the said Contract as liquidated damages, is any, shall be forfeited to the Obligeo, its successor or assigns, in the event of a breach of any, or all, or any part of, the covenants, agreements, conditions, or stipulations contained in the Contract or in this bond in accordance with the terms thereof.

The amount of this bond may be reduced by and to the extent of any payment or payments made in good faith hereunder.

Signed and sealed this _____ day of _____, 20_____.

(Seal)

Name of Contractor

*

Signature

Title

*ALL SIGNATURES MUST BE ACKNOWLEDGED BY A NOTARY PUBLIC

PERFORMANCE BOND FOR SUPPLEMENTAL AGREEMENT FOR GOODS AND SERVICES (EXHIBIT G)

EXHIBIT H - CONTRACTOR ACKNOWLEDGMENT

[FOR USE WITH PERFORMANCE AND PAYMENT BONDS]
(11/15/11)

CONTRACTOR ACKNOWLEDGMENT:

STATE OF _____)
) : SS
_____ COUNTY OF _____)

On this _____ day of _____, 20____, before me appeared _____
and _____ to me known to be the person(s) described in and, who, being duly sworn,
did say that he/she/they is/are _____ and _____
of _____ the Contractor named in the foregoing instrument, and that he/she/they
is/are authorized to sign said instrument in behalf of the contractor, and acknowledges that he/she/they executed said
instrument as the free act and deed of the Contractor.

(Notary Seal)
Notary Public

State of _____
My commission expires _____

CONTRACTOR ACKNOWLEDGMENT (EXHIBIT H)

EXHIBIT I - SURETY ACKNOWLEDGMENT

[FOR USE WITH SURETY PERFORMANCE AND PAYMENT BONDS]
(11/15/11)

SURETY ACKNOWLEDGMENT:

STATE OF _____)
) : SS
_____ COUNTY OF _____)

On this _____ day of _____, 20____, before me personally came _____ to me known to be the person described in and who, acting by me, did depose and say that _____ resides in _____; that _____ is the Attorney-in-Fact of _____ the corporation described _____ and which executed the attached instrument; that _____ knows corporate seal of the said corporation that the seal affixed to the said instrument is such corporate seal; and that it was so affixed by order of the Board of Directors of the said corporation; and that _____ signed _____ name thereto by live order.

Notary Public (Notary Seal)
State of _____
My commission expires: _____

Not Applicable, Refer to Exhibit J

EXHIBIT J – SAMPLE CONTRACT

SAMPLE CONTRACT
(05/19/16)



CONTRACT NO. _____

CONSTRUCTION CONTRACT

THIS CONTRACT, effective as of the date of the last signatory, is made and entered into by and between the **Board of Water Supply, County of Kaua'i**, whose mailing address is 4398 Pua Loke Street, Lihu'e, Hawai'i 96766 (hereinafter the "BOARD") and _____, a _____, under the laws of the State of _____, whose principle mailing address is _____ (hereinafter the "CONTRACTOR");

THIS CONTRACT for construction services has been procured under:

- Hawai'i Revised Statute (H.R.S.) §103D-302 (Competitive Sealed Bidding)
- H.R.S. §103D-303 (Competitive Sealed Proposals)
- H.R.S. §103D-305 (Small Purchase)
- H.R.S. §103D-307 (Emergency Procurement # _____)

WITNESSETH:

THAT, for and in consideration of the payment(s) hereinafter set forth to be made by the Board, the Contractor agrees to furnish and pay for all materials, supplies, tools, equipment, labor, utilities, transportation, services, and any and all other incidentals necessary to construct in place and complete, free of all liens, claims, and any encumbrances whatsoever:

(hereinafter "PROJECT").

1. Contract Documents: The Contractor agrees to complete the PROJECT in accordance with this Contract and the following documents:

- Approved construction drawings;
- Specifications;
- Invitation for Bids Document No. _____ and all Addenda thereto;
- Request for Proposals PROJECT No. _____ and all Addenda thereto;

- Bid/Proposal/Best and Final Offer;
- Method of Award;
- Wage Rate Schedule;
- Construction Schedules;
- Special Provisions;
- General Provisions for Construction Contracts of the Department of Water Dated April 25, 2016;

and those other documents attached or referred to therein, relating to the PROJECT (hereinafter collectively referred to as "Contract Documents"). The Contractor understands and agrees that the Contract Documents including, but not limited to, those referenced in but not attached to this Contract and those referenced in but not attached to the Contract Documents, are hereby incorporated by reference into this Contract. The Contractor acknowledges and admits receipt of all Contract Documents, and acknowledges that it has reviewed, understands, and agrees with all terms and conditions in the Contract Documents and those other documents, terms and conditions referenced therein.

2. **Time of Performance:** The Contractor agrees to complete the PROJECT within _____ CALENDAR DAYS, from and including the date as specified in the written Notice to Proceed.
3. **Compensation:** For and in consideration of the Contractor's full and faithful performance of this entire Contract, the Board hereby agrees to pay the Contractor the sum of

DOLLARS (\$_____), federal, state and local taxes included, in lawful money of the United States of America; provided that the Contractor understands and agrees that payment shall be made in the manner and at the times specified in the Contract Documents, and shall also be subject to and conditioned upon such additions to or deductions from the preceding sum as may herein be made, according to the Contract Documents.

4. **Liquidated Damages:** THE CONTRACTOR UNDERSTANDS AND AGREES that time is an essential factor of this Contract; that the Board will suffer material loss by reason of delays that may occur in the Contractor's performance of the work or any portions of the work within the time or times fixed in the Contract or any extensions thereto; and that as liquidated damages for any such delays, the sum of

DOLLARS (\$_____), for each and every calendar day which said performance remains uncompleted will be charged the Contractor and deducted from the Contract price; and it is expressly stipulated by and between the Contractor and Board that any such sums shall be deemed and taken to be liquidated damages for the Contractor's failure to perform within the specified time and not be in the nature of penalty.

5. **Bonds:** The Contractor is required to provide the following bonds, in an amount equal to 100% of the amount of the Contract price in the form(s) set forth in **Exhibit A:**

- Performance Bond (**Exhibit A1**)
- Labor and Material Payment Bond (**Exhibit A2**)
- Not Applicable

6. **Insurance:** Contractor shall procure and maintain, on primary basis and at its sole expense, at all times during the life of the Contract insurance coverages, limit, including endorsements as described in **Exhibit B,** incorporated herein, against claims for injuries to person or damages to property which may arise from or in connection with the performance of the work by the Contractor or the Contractor's agents, representatives, employees or subcontractors. The requirements contained herein, as well as the Board's review or acceptance of insurance maintained by the contractor is not intended to and shall not in any manner limit or qualify the liabilities or obligations assumed by the Contractor.

7. **Officer in Charge:** The Officer in Charge of this PROJECT is:

8. **Severability:** In the event any term or provision of this Contract is declared to be invalid or illegal for any reason, this Contract will remain in full force and effect and will be interpreted as though such invalid or illegal provision were not a part of this Contract.

9. **Execution in Counterparts:** This Contract may be executed in counterparts, all of which shall be considered the same as if a single document shall have been executed, but shall become effective when such counterparts have been signed by each of the parties hereto and delivered to each party. Further, facsimile signatures and notarizations are permissible provided original signatures and notarizations bearing the notary's seal are later provided to the party in receipt of the facsimile signature and notarizations.

10. **Waiver:** Waiver of a breach or default under this Agreement shall not constitute a continuing waiver or a waiver of a subsequent breach of the same or any other provision of this Agreement.

THE PARTIES FURTHER AGREE that:

- Concurrently with its execution of this Contract, Contractor shall submit to the Officer-in-Charge:
 - a tax clearance pursuant to Haw. Rev. Stat., as amended (hereinafter "H.R.S." §103-53;
 - a Certificate of Compliance pursuant to Hawai'i Administrative Rules (hereinafter "H.A.R.") §3-122-112; and

- a Certificate of Good Standing pursuant to H.A.R. §3-122-112.

Further, as a condition of final payment on this Contract, Contactor shall submit to the Officer-in-Charge:

- a tax clearance to pursuant to H.R.S. §103-53; and
- a Certificate of Compliance pursuant to H.A.R. §3-122-112.

All clearances and certificates submitted pursuant to the foregoing statutory requirements shall be valid when the Contract is executed by all parties hereto and when final payment is made.

As used in this Contract, “Board” means the Board of Water Supply of the County of Kaua‘i and the Department of Water, County of Kaua‘i, and its officers, agents, and employees.

IN WITNESS WHEREOF, the parties hereto have hereunto caused this instrument to be executed as of the _____ day of _____, _____.

APPROVED:

BOARD OF WATER SUPPLY
COUNTY OF KAUA‘I

By _____

APPROVED AS TO FORM
AND LEGALITY:

CONTRACTOR

By _____
Its _____

By _____
Its _____

STATE OF HAWAI'I)
) ss.
COUNTY OF _____)

On this _____ day of _____, _____, before me appeared
_____ to me personally known, who being by me was duly sworn, did say he/she is the ___
_____ of _____, a _____ and that said instrument
was signed and sealed on behalf of said _____; and said officer acknowledged said instrument to be
the free act and deed of said _____.

Notary Public, State of Hawai'i

Name of Notary: _____

My commission expires: _____

(PLEASE INSERT YOUR APPLICABLE NOTARY SECTION)

EXHIBIT A1
PERFORMANCE BOND (SURETY)

KNOW ALL MEN BY THESE PRESENTS:

That _____,

a _____ corporation, whose principle mailing address is

_____,

as Principal, (hereinafter referred to as "Principal"), and _____,

as Surety, (hereinafter referred to as "Surety"), a corporation(s) authorized to transact business as a surety in the State of Hawai'i, are held and firmly bound unto the Board of Water Supply, its successors and assigns, (hereinafter referred to as "Obligee"), in the amount of

DOLLARS (\$_____) to which payment Principal and Surety bind themselves, their heirs, executors, administrators, successors and assigns, jointly and severally, firmly by these presents.

WHEREAS, the above-bound Principal has entered into a Contract with Obligee dated _____ for _____ (hereinafter referred to as the "Contract"), which Contract is incorporated herein by reference and made a part hereof.

NOW THEREFORE, the condition of this obligation is such that:

If the Principal shall promptly and faithfully perform, and fully complete the Contract in strict accordance with the terms of the Contract as said Contract may be modified or amended from time to time; then this obligation shall be void; otherwise to remain in full force and effect.

Surety to this bond hereby stipulated and agrees that no changes, extensions of time, alterations, or additions to the terms of the Contract, including the work to be performed thereunder, and the specifications or drawings accompanying same, shall in any way affect its obligation on this bond, and it does hereby waive notice of any such changes, extensions of time, alterations, or additions, and agrees that they shall become part of the Contract.

In the event of Default by the Principal, of the obligations under the Contract, then after written Notice of Default from the Obligee to the Surety and the Principal, Surety shall either remedy the Default, or take over the work to be performed under the contract and complete such work, subject, however, to the limitation of the penal sum of this bond.

Signed and sealed this _____ day of _____, _____.

Principal Seal

By _____

Its By _____

Its _____

Surety Seal

By _____

Its By _____

Its _____

ALL SIGNATURES MUST BE ACKNOWLEDGED BY A NOTARY PUBLIC

SURETY PERFORMANCE BOND

STATE OF HAWAI'I)
) ss.
COUNTY OF _____)

On this _____ day of _____, _____, before me appeared _____ to me personally known, who being by me was duly sworn, did say he/she is the _____ of _____, a _____; that the seal affixed to the foregoing instrument is the _____ seal of said _____; and said officer acknowledged said instrument to be the free act and deed of said _____.

Notary Public, State of Hawai'i

Name of Notary: _____

My commission expires: _____

(SURETY PLEASE INSERT YOUR APPLICABLE NOTARY SECTION.)

**EXHIBIT A1
PERFORMANCE BOND**

KNOW TO ALL BY THESE PRESENTS:

That we, _____, as Contractor, hereinafter called Contractor, is held and firmly bound unto the _____, its successors and assigns, as Obligee, hereinafter called Obligee, in the amount of

_____ **DOLLARS** (\$_____), lawful money of the United States of America, for the payment of which to the said Obligee, well and truly to be made, Contractor binds itself, its heirs, executors, administrators, successors and assigns, firmly by these presents. Said amount is evidenced by:

- Legal tender;
- Share Certificate unconditionally assigned to or made payable at sight to

Description _____;
- Certificate of Deposit, No. _____, dated _____,

issued by _____,
drawn on _____,
a bank, savings institution or credit union insured by the Federal Deposit Insurance Corporation or the Nation Credit Union Administration, payable at sight or unconditionally assigned to _____;
- Cashier's Check No. _____, dated _____,
issued by _____,
drawn on _____,
a bank, savings institution or credit union insured by the Federal Deposit Insurance Corporation or the National Credit Union Administration, payable at sight or unconditionally assigned to _____;
- Teller's Check No. _____, dated _____,
issued by _____,
drawn on _____;

a bank, savings institution or credit union insured by the Federal Deposit Insurance Corporation or the National Credit Union Administration, payable at sight or unconditionally assigned to

_____;

Treasurer's Check No. _____, dated _____,

issued by _____,

drawn on _____,

a bank, savings institution or credit union insured by the Federal Deposit Insurance Corporation or the National Credit Union Administration, payable at sight or unconditionally assigned to

_____;

Official Check No. _____, dated _____,

issued by _____,

drawn on _____,

a bank, savings institution or credit union insured by the Federal Deposit Insurance Corporation or the National Credit Union Administration, payable at sight or unconditionally assigned to

_____;

Certified Check No. _____, dated _____,

accepted by a bank, savings institution or credit union insured by the Federal Deposit Insurance Corporation or the National Credit Union Administration, payable at sight or unconditionally assigned _____;

WHEREAS:

The Contractor has by written agreement dated _____ entered into a contract with Oblige
for the following PROJECT:

hereinafter called Contract, which Contract is incorporated herein by reference and made a part hereof.

NOW, THEREFORE,

The condition of this obligation is such that, if Contractor shall promptly and faithfully perform the Contract in accordance with, in all respects, the stipulations, agreements, covenants and conditions of the Contract as it now exists or may be modified according to its terms, and shall deliver the PROJECT to the Oblige, or to its successors or assigns, fully completed as in the Contract specified and free from all liens and claims and without further cost, expense or charge to the Oblige, its officers, agents, successors or assigns, free and harmless from all suits or actions of every

nature and kind which may be brought for or on account of any injury or damage, direct or indirect, arising or growing out of the doing of said work or the repair or maintenance thereof or the manner of doing the same or the neglect of the Contractor or its agents or servants or the improper performance of the Contract by the Contractor or its agents or servants or from any other cause, then this obligation shall be void; otherwise it shall be and remain in full force and effect.

AND IT IS HEREBY STIPULATED AND AGREED that suit on this bond may be brought before a court of competent jurisdiction without a jury, and that the sum or sums specified in the said Contract as liquidated damages, if any, shall be forfeited to the Obligee, its successors or assigns, in the event of a breach of any, or all, or any part of, the covenants, agreements, conditions, or stipulations contained in the Contract or in this bond in accordance with the terms thereof.

The amount of this bond may be reduced by and to the extent of any payment or payments made in good faith hereunder.

Signed this _____ day of _____, _____.

(Seal) _____
Name of Contractor
* _____
Signature

Title

STATE OF HAWAI'I)
) ss.
COUNTY OF _____)

On this _____ day of _____, _____, before me appeared _____ to me personally known, who being by me was duly sworn, did say he/she is the _____ of _____, a _____; that the seal affixed to the foregoing instrument is the _____ seal of said _____; and said officer acknowledged said instrument to be the free act and deed of said _____.

Notary Public, State of Hawai'i
Name of Notary: _____
My commission expires: _____

ALL SIGNATURES MUST BE ACKNOWLEDGED BY A NOTARY PUBLIC.

EXHIBIT A2
LABOR AND MATERIAL PAYMENT BOND (SURETY)

KNOW ALL MEN BY THESE PRESENTS:

That _____, a _____
corporation, whose principle mailing address is _____,
as Principal (hereinafter referred to as "Principal"), and _____,
as Surety (hereinafter referred to as "Surety"), a corporation(s) authorized to transact business as a surety in the State of
Hawai'i, are held and firmly bound unto the Board of Water Supply, its successors and assigns (hereinafter referred to
as "Obligee"), in the amount of

DOLLARS (\$ _____), to which payment Principal and Surety bind themselves, their heirs, executors,
administrators, successors and assigns, jointly and severally, firmly by these presents.

WHEREAS, the above-bound Principal has entered into a Contract with Obligee dated _____
for _____ (hereinafter referred to as the "Contract"), which
Contract is incorporated herein by reference and made a part hereof.

NOW, THEREFORE, the condition of this obligation is such that if the Principal shall promptly make
payment to any Claimant, as hereinafter defined, for all labor and materials supplied to the Principal for use in the
performance of the Contract, then this obligation shall be void; otherwise to remain in full force and effect.

1. Surety to this Bond hereby stipulates and agrees that no changes, extensions of time, alterations, or
additions to the terms of the Contract, including the work to be performed thereunder, and the
specifications or drawings accompanying same, shall in any way affect its obligation on this bond,
and it does hereby waive notice of any such changes, extensions of time, alterations, or additions,
and agrees that they shall become part of the Contract.
2. A "Claimant" shall be defined herein as any person who has furnished labor or materials to the
Principal for the work provided in the Contract.

As provided in Section 103D-324, Hawai'i Revised Statutes, every Claimant who has not been paid in full
before the expiration of a period of ninety days after the day on which the last of the labor was done or performed or
material was furnished or supplied, for which such a claims made, may institute an action against the Principal or the
Principal and its Surety, on this bond and have their rights and claims adjudicated in the action, and judgment rendered
thereon; subject to the Obligee's priority on the bond. If the full amount of the liability of the Surety on the bond is

insufficient to pay the full amount of the claims, then after paying the full amount due the Oblige, the remainder shall be distributed pro rata among the claimants.

Signed and sealed this _____ day of _____, _____.

Principal Seal

By _____

Its By _____

Its _____

Surety Seal

By _____

Its By _____

Its _____

ALL SIGNATURES MUST BE ACKNOWLEDGED BY A NOTARY PUBLIC.

SURETY LABOR AND MATERIAL
PAYMENT BOND

STATE OF HAWAI'I)
) ss.
COUNTY OF _____)

On this _____ day of _____, _____, before me appeared
_____ to me personally known, who being by me was duly sworn, did say he/she is the _
_____ of _____, a _____; that the seal affixed to the
foregoing instrument is the _____ seal of said _____; and said officer acknowledged said
instrument to be the free act and deed of said _____.

Notary Public, State of Hawai'i

Name of Notary: _____

My commission expires: _____

(SURETY PLEASE INSERT YOUR APPLICABLE NOTARY SECTION)

EXHIBIT A2
LABOR AND MATERIAL PAYMENT BOND
(11/17/98)

KNOW TO ALL BY THESE PRESENTS:

That we, _____, as Contractor, hereinafter called Contractor, is held and firmly bound unto the _____, its successors and assigns, as Obligee, hereinafter called Obligee, in the amount of

DOLLARS (\$ _____), lawful money of the United States of America, for the payment of which to the said Obligee, well and truly to be made, Contractor binds itself, its heirs, executors, administrators, successors and assigns, firmly by these presents. Said amount is evidenced by:

Legal tender;

Share Certificate unconditionally assigned to or made payable at sight to

Description

_____;

Certificate of Deposit, No. _____, dated _____,
issued by _____,
drawn on _____,

a bank, savings institution or credit union insured by the Federal Deposit Insurance Corporation or the National Credit Union Administration, payable at sight or unconditionally assigned to

_____;

Cashier's Check No. _____, dated _____,
issued by _____,
drawn on _____,

a bank, savings institution or credit union insured by the Federal Deposit Insurance Corporation or the National Credit Union Administration, payable at sight or unconditionally assigned to

_____;

Teller's Check No. _____, dated _____,
issued by _____,
drawn on _____,

a bank, savings institution or credit union insured by the Federal Deposit Insurance Corporation or the National Credit Union Administration, payable at sight or unconditionally assigned to

Treasurer's Check No. _____, dated _____,
issued by _____,
drawn on _____;

a bank, savings institution or credit union insured by the Federal Deposit Insurance Corporation or the National Credit Union Administration, payable at sight or unconditionally assigned to

Official Check No. _____, dated _____,
issued by _____,
drawn on _____;

a bank, savings institution or credit union insured by the Federal Deposit Insurance Corporation or the National Credit Union Administration, payable at sight or unconditionally assigned to

Certified Check No. _____, dated _____,
accepted by a bank, savings institution or credit union insured by the Federal Deposit Insurance Corporation or the National Credit Union Administration, payable at sight or unconditionally assigned _____;

WHEREAS:

The Contractor has by written agreement dated _____ entered into a contract with Obligee for the following PROJECT:

_____ hereinafter called Contract, which Contract is incorporated herein by reference and made a part hereof.

NOW, THEREFORE,

The condition of this obligation is such that, if Contractor shall promptly and faithfully perform the Contract in accordance with, in all respects, the stipulations, agreements, covenants and conditions of the Contract as it now exists or may be modified according to its terms, free from all liens and claims and without further cost, expense or charge to the Obligee, its officers, agents, successors or assigns, free and harmless from all suits or actions of every nature and kind which may be brought for or on account of any injury or damage, direct or indirect, arising or growing

out of the doing of said work or the repair or maintenance thereof or the manner of doing the same or the neglect of the Contractor or its agents or servants or the improper performance of the Contract by the Contractor or its agents or servants or from any other cause, and shall promptly pay all persons supplying labor and materials for the performance of the Contract, then this obligation shall be void; otherwise it shall be and remain in full force and effect.

AND IT IS HEREBY STIPULATED AND AGREED that suit on this bond may be brought before a court of competent jurisdiction without a jury, and that the sum or sums specified in the said Contract as liquidated damages, if any, shall be forfeited to the Obligee, its successors or assigns, in the event of a breach of any, or all, or any part of, the covenants, agreements, conditions, or stipulations contained in the Contract or in this bond in accordance with the terms thereof.

AND IT IS HEREBY STIPULATED AND AGREED that this bond shall inure to the benefit of any and all persons entitled to file claims for labor performed or materials furnished in said work so as to give any and all such persons a right of action as contemplated by Sections 103D-324(d) and 103D-324(e), Hawai'i Revised Statutes.

The amount of this bond shall be reduced by and to the extent of any payment or payments made in good faith hereunder, inclusive of the payment of mechanics' liens which may be filed of record against the PROJECT, whether or not claim for the amount of such lien be presented under and against this bond.

Signed this _____ day of _____, _____.

(Seal) _____
Name of Contractor

* _____
Signature

Title

STATE OF HAWAI'I)
) ss.
COUNTY OF _____)

On this _____ day of _____, _____, before me appeared _____ to me personally known, who being by me was duly sworn, did say he/she is the _____ of _____, a _____; that the seal affixed to the foregoing instrument is the _____ seal of said _____; and said officer acknowledged said instrument to be the free act and deed of said _____.

Notary Public, State of Hawai'i
Name of Notary: _____
My commission expires: _____

(ALL SIGNATURES MUST BE ACKNOWLEDGED BY A NOTARY PUBLIC)

EXHIBIT B
INSURANCE REQUIREMENTS
BOARD OF WATER SUPPLY COUNTY OF KAUA'I

Contractor shall procure and maintain, on primary basis and at its sole expense, at all times during the life of the contract insurance coverages, limits, including endorsements described herein against claims for injuries to persons or damages to property which may arise from or in connection with the performance of the work by the Contractor or the Contractor's agents, representatives, employees or subcontractors. The requirements contained herein, as well as the Department of Water, County of Kaua'i's (hereinafter "DOW") review or acceptance of insurance maintained by the Contractor is not intended to and shall not in any manner limit or qualify the liabilities or obligations assumed by the Contractor.

To the extent applicable, the amounts and types of insurance will conform to the minimum terms, conditions and coverage(s) of Insurance Service Office (ISO) policies, forms, and endorsements.

A. General Conditions

Waiver of Subrogation. Contractor shall agree by entering into a contract with the Board of Water Supply, County of Kaua'i (hereinafter "Board") to provide a Waiver of Subrogation for the Commercial General Liability, Automobile Liability, and Workers Compensation policies. When required by the insurer, or should a policy condition not permit Contractor to enter into a pre-loss agreement to waive subrogation without an endorsement, the Contractor shall agree to notify the insurer and request the policy be endorsed with a Waiver of Subrogation in favor of the Board. This Waiver of Subrogation requirement shall not apply to any policy, which includes a condition specifically prohibiting such an endorsement, or voids coverage should Contractor enter into such an agreement on a pre-loss basis.

Subcontractors. If applicable, Contractor shall include all subcontractors as additional insureds under its policies and shall retain the records of the separate certificates and endorsements for each subcontractor. All coverages for subcontractors shall be subject to the same requirements as the Contractor as stated herein.

APPLICABLE

NOT APPLICABLE

Additional Insured. Contractor shall agree to endorse the **BOARD OF WATER SUPPLY, COUNTY OF KAUA'I as an Additional Insured** with a CG026 Additional Insured – Designated Person or Organization endorsement, a copy of the applicable policy language, or similar endorsement to all required insurance policy(ies), except for Workers Compensation and Professional Liability.

Deductibles and Self-Insured Retentions. Any deductibles or self-insured retentions must be declared to and approved by the DOW. At the option of the DOW, either: the insurer shall reduce or eliminate such deductibles or self-insured retentions as respects the Board; or the Contractor shall provide a financial guarantee (audited financial statement) satisfactory to the Department guaranteeing payment of losses and related investigations, claim administration and defense expenses.

When a self-insured retention (SIR) or deductible exceeds \$50,000, the Department reserves the right, but not the obligation, to review and request a copy of the Contractor's most recent annual report or audited financial statement.

Contractor's Responsibility. The Contractor is responsible for paying any portion of any loss not covered because of the operation of any deductible, co-insurance clause or self-insured retention applicable to the insurance required herein. If the Board is damaged by the failure of the Contractor to maintain insurance as required in this paragraph, then the Contractor shall bear all reasonable costs properly attributable to that failure.

Primary and Non-contributory. All policies required of the Contractor will be endorsed as primary and any insurance or self-insurance program maintained by the Board shall be non-contributory.

Certificate of Insurance. Concurrent with the execution of the contract, Contractor shall provide the Department a certificate of insurance completed by a duly authorized representative of their insurer certifying that the liability coverage(s) is written on an occurrence form. Immediately upon becoming aware that its insurance will be cancelled, non-renewed, or materially changed, Contractor will notify Department by providing written notice.

The Certificate Holder address shall read:

Board of Water Supply, County of Kaua'i
4398 Pua Loke Street, Lihue, HI 96766

Attention: (_____ **Name of Contact Person**)

Contract No. _____

Project Title _____

Concurrent with the execution the contract the Contractor shall furnish the Department with original certificates and endorsements effecting required coverage(s). The Department reserves the right to require complete copies of all required insurance policies, including the policy declarations and endorsements affecting the coverage at any time.

Failure to secure and maintain the required insurance shall be considered as a material breach of the contract. Should the Board be forced to expend funds that would have been covered under the specified insurance, Contractor shall reimburse the Board for such funds. In the event the Board determines, in its sole and absolute discretion, that it is necessary to purchase the coverages herein required of the Contractor, and which the Contractor has failed to secure, the Contractor shall reimburse the Board for the expenditure of such funds.

Right to Revise or Reject. Department reserves the right, but not the obligation, to review and revise any insurance requirement, not limited to limits, coverages and endorsements based on insurance market conditions affecting the availability or affordability of coverage; or changes in the scope of work or specifications affecting the applicability of coverage. Additionally, the Department reserves the right, but not the obligation, to review and reject any insurance policies failing to meet the criteria stated herein or any insurer providing coverage due to its poor financial condition or failure to operate legally.

B. Minimum Insurance Coverage Requirements

Unless otherwise approved by the Manager and Chief Engineer, the policy or policies of insurance maintained by the Contractor shall provide the following minimum limit(s) and coverage(s) as specified herein and be placed with an insurance carrier authorized to do business in the State of Hawaii and rated A-VII by A.M. Best:

Commercial General Liability. The Contractor shall procure and maintain Commercial General Liability, with dedicated required limits, as set forth herein, written on occurrence form providing:

Designated premises basis

OR

Per Project basis

The coverages shall include the following:

- Premises Operations
- Independent Contractors
- Products and Completed Operations
- Broad Form Property Damage including completed operations
- Blanket Contractual Liability
- Personal Injury
- Employees named as Additional Insured
- Severability of Interest
- Explosion, Collapse and Underground Property Damage

The minimum limits of liability may be satisfied by providing either:

<p>Bodily Injury and Property Damage Combined Single Limit:</p> <p><input type="checkbox"/> \$2,000,000 per occurrence</p> <p><input type="checkbox"/> \$2,000,000 annual aggregate</p>	<p>OR</p>	<p>Personal Injury:</p> <ul style="list-style-type: none"> ▪ \$1,000,000 per occurrence ▪ \$2,000,000 annual aggregate <p>AND</p> <p>Products and Completed Operations:</p> <ul style="list-style-type: none"> ▪ \$1,000,000 per occurrence ▪ \$2,000,000 annual aggregate
--	------------------	---

Contractor must provide evidence the Board is an Additional Insured for Products/Completed Operations coverage for both ongoing operations and after substantial completion of the work. This coverage may be provided by the ISO form CG 2010 (11 85) or an equivalent policy form. Coverage provided by a non-equivalent CGL form shall be specifically endorsed providing both the course of construction and products/completed operations. ISO CG 2010 (04 13) and ISO form CG 2037 (04 13) or an equivalent form is required from the Contractor. The Contractor and subcontractor(s), if any, shall provide evidence to the Department on an annual basis the products/completed operation coverage is in effect for two (2) years after substantial completion of the project.

- Business Automobile Liability.** The Contractor shall procure and maintain Business Automobile Liability written on occurrence form for all Owned, Non-owned, and Hired automobiles. If the Contractor does not own automobiles, Contractor shall agree to maintain coverage for Hired & Non-Owned Auto Liability, which may be satisfied by way of endorsement to the Commercial General Liability policy or separate Business Automobile Liability. Coverage shall be for automobile contractual liability, uninsured and underinsured motorist coverage, basic no-fault, and personal injury protection, as required by Hawai'i law with the following limits:

Bodily Injury
\$1,000,000 per person
\$1,000,000 per occurrence
Property Damage
\$1,000,000 per accident

- Workers' Compensation and Employer's Liability.** The Contractor shall procure and maintain at all times during the term of the contract the following insurance liability coverage: Workers' Compensation, Temporary Disability Insurance (TDI), and similar insurance that is required by the State of Hawai'i or federal laws. Self-insurance is permitted subject to submission of a copy of the appropriate governmental authorization and qualification by the Contractor and subcontractor(s).
The minimum limits of liability to be maintained are as follows:

Coverage A: State of Hawai'i Workers' Compensation Law:
Statutory Limits.

Coverage B: Employer's Liability:
Bodily Injury from each accident \$1,000,000
Bodily Injury from disease \$1,000,000
Bodily Injury from disease aggregate \$1,000,000

- Builder's Risk.** The Contractor shall procure and maintain an Inland Marine Builder's Risk policy providing coverage to protect the interests of the Board, Contractor, sub-contractors, architects, and engineers, including property in transit and property on or off- premises, which shall become part of the building, or Project. Coverage shall be written on an **All Risk, Replacement Cost, and Completed Value Form** basis in an amount at least equal to 100% of the projected completed value of the Project as well as subsequent modifications of that sum, unless an agreed amount is otherwise stated between the Department and the Contractor. The policy shall insure all work, labor, and materials furnished by the Contractor and the Contractor's subcontractors against loss occasioned by fire, lightning, windstorm, theft, vandalism, malicious mischief, flood, earthquake, and collapse.

The amount of coverage for the perils of flood and earthquake may be subject to a sub-limit. The sub-limit shall provide coverage of at least 25% of the full replacement cost.

The policy shall also include coverage for debris removal and reasonable compensation for architect's and engineer's services and expenses required as a result of an insured loss. The Contractor shall endorse the policy with a manuscript endorsement eliminating the automatic termination of coverage in the event the building is occupied in whole or in part, or put to its intended use, or partially accepted by the Department. The manuscript endorsement shall amend the automatic termination clause to only terminate coverage if the policy expires, is cancelled, the Board's interest in the building ceases, or the building is accepted or insured by the Board.

The Contractor shall name the Board of Water Supply, County of Kaua'i as a loss payee on the Builder's Risk policy.

Installation Floater. The Contractor shall procure and maintain an Installation Floater policy providing coverage to protect the interests of the Board, Contractor, sub-contractor(s), architects, and engineers, including property in transit and property on or off-premises, which shall become part of the project.

Coverage shall be written on an All Risk, Replacement Cost, and Completed Value Form basis in an amount at least equal to 100% of the projected completed value of the Project as well as subsequent modifications of that sum, unless an agreed amount is otherwise stated between the Department and the Contractor. The policy shall insure all work, labor, and materials furnished by the Contractor and the Contractor's subcontractors against loss occasioned by fire, lighting, windstorm, theft, vandalism, malicious mischief, flood, earthquake, and collapse.

The amount of coverage for the perils of flood and earthquake may be subject to a sub-limit. The sub-limit shall provide coverage of at least 25% of the full replacement cost.

The policy shall also include coverage for debris removal and reasonable compensation for architect's and engineer's services and expenses required as a result of an insured loss. The Contractor shall endorse the policy with a manuscript endorsement eliminating the automatic termination of coverage in the event the building is occupied in whole or in part, or put to its intended use, or partially accepted by the Department. The manuscript endorsement shall amend the automatic termination clause to only terminate coverage if the policy expires, is cancelled, the Board's interest in the building ceases, or the building is accepted or insured by the Board.

The Contractor shall name the Board of Water Supply, County of Kaua'i as a loss payee on the Installation Floater policy.

Professional Liability (Errors and Omissions). The Contractor and its subcontractors shall procure and maintain Professional Liability Insurance (Errors and Omissions Insurance) that covers all such activities under the contract. Such insurance shall have these minimum limits and coverage(s):

\$1,000,000 per occurrence
\$2,000,000 annual aggregate

For policies written on a "Claims-Made" basis, Contractor warrants the retroactive date equals or precedes the effective date of the contract. In the event the policy is canceled, non-renewed, switched to an Occurrence Form, retroactive date advanced; or any other event triggering the right to purchase a Supplemental Extended Reporting Period (SERP) during the life of the contract, Contractor shall agree to purchase Supplemental Extended Reporting Period (SERP) with a minimum reporting period not less than **two (2)** years.

The requirement to purchase a SERP shall not relieve Contractor of the obligation to provide replacement coverage.

Pollution Legal Liability. The Contractor shall procure and maintain Pollution Liability or similar Environmental Impairment Liability at a minimum limit not less than:

\$1,000,000 per occurrence
\$2,000,000 annual aggregate

The policy shall provide coverage for damages against, but not limited to, third-party liability, clean-up, corrective action including assessment, remediation and defense costs.

Contractor's Pollution Liability. Contractor shall procure and maintain pollution liability insurance when the Scope of Work involves removal, abatement, encapsulation or other treatment, disposal or remediation of asbestos or other hazardous materials or an exposure to pollutants or impairment of the environment. The policy shall provide coverage for third party liability, clean-up, and corrective action including assessment remediation and defense costs. The policy may be written on either an occurrence form or claims made. The minimum limits of liability shall be:

\$1,000,000 per occurrence
\$2,000,000 annual aggregate

Crime Insurance or Commercial Fidelity Bond: Contractor shall procure and maintain Commercial Crime Insurance or Fidelity Bond providing Employee Dishonesty on a blanket basis covering all of the Contractor's employees with a minimum amount of insurance at least equal to the amount of the contract. The policy shall be endorsed to cover "Third-Party Liability" including a third-party beneficiary clause in favor of the Board. The policy shall include a minimum twelve (12) month "Discovery Period" when written on a Loss Sustained basis.

Property. The Tenant or Lessee, shall agree to maintain property insurance including flood and windstorm written on a replacement cost basis in an amount not less than 100% of the replacement cost of the building(s) and contents, including betterments and improvements made by the Tenant or Lessee, located on the premises. Contractor shall agree to be fully responsible for any deductible or self-insured retention, and to provide this coverage on primary basis.

Umbrella or Excess Liability. Contractor may satisfy the minimum liability limits required above under an Umbrella or Excess Liability policy with \$1,000,000 per occurrence and \$2,000,000 aggregate. If Contractor is using its Umbrella or Excess Liability Insurance policy to satisfy the minimum requirements, Contractor shall agree to endorse the Board of Water Supply, County of Kaua'i as "Additional Insured" on the Umbrella or Excess Liability policy, or shall confirm in writing that its Umbrella or Excess Liability policy "follows form."

CONTRACT (EXHIBIT J)

EXHIBIT K - CONTRACT CHANGE ORDER

CONTRACT CHANGE ORDER DEPARTMENT OF WATER COUNTY OF KAUAI

Project						Order No.	
						Date	
Project No.			Change Requested By:			Contract No.	
To _____, Contractor:							
Estimate of Quantities and Costs:							
Item No.	Item	Quantity	Unit	Contract Unit Price	Agreed Unit Price	\$ Amount (+ or -)	
CONTRACT PRICE			CONTRACT CERTIFICATION			CONTRACT TIME	
<input type="checkbox"/> No Change <input type="checkbox"/> Increased by \$ _____ <input type="checkbox"/> Decreased by \$ _____			Amount Certified \$ _____ New Contract Price \$ _____			<input type="checkbox"/> No Change <input type="checkbox"/> Increased by _____ Calendar days <input type="checkbox"/> Decreased by _____ Calendar days	
Submitted by:			Approved:			Accepted:	
Project Engineer Date			Fiscal Officer Date				
ED&C Division Head Date			Mgr & Chief Engineer Date				
<p>This Change Order No. ___ is issued pursuant to the Contract and, upon execution, shall become incorporated in the Contract. The amount set forth in this Change Order comprises the total compensation due the Contractor, all Subcontractors, and all Suppliers, for any work performed under this Change Order, including impact on unchanged work. The signing of this Change Order indicates that the Change Order constitutes full mutual accord and satisfaction for the contract including any change and that the charge under this Change Order constitutes the total equitable adjustment owed the Contractor, all Subcontractors, and all Suppliers under this contract. Any future dispute regarding time required for performance or contract price as related to this Change Order is subject to the terms of the General Provisions for Construction Contracts of the Department of Water, County of Kaua'i as amended and Hawai'i Revised Statutes and Hawai'i Administrative Rules.</p>							
Accepted:							
Contractor		Title				Date	

CONTRACT CHANGE ORDER (EXHIBIT K)

EXHIBIT L – CONTRACT MODIFICATION FORM

CONTRACT MODIFICATION FORM (11/15/11)

DEPARTMENT OF WATER
COUNTY OF KAUAI
STATE OF HAWAII

MODIFICATION ORDER NO. _____ Date _____

Contractor _____ Contract No. _____

Contract Title _____

A. MODIFICATIONS

The following modifications are to be performed in accordance with all contract stipulations (specifications, delivery point, rate of delivery, period of performance, price, quantity, or other provisions by mutual action of the parties to the contract.)

B. CONTRACTOR'S QUOTATION

The modifications described in "A" above will be performed at a contract price ____ increase ____ decrease of \$ _____. Contractor will not undertake to perform the changes in "A" above until this modification order has been approved and issued.

Contractor's Signature and Date

C. STATEMENT OF CONTRACT FUNDS

Original Contract Price \$ _____

Previous Adjusted Contract Price \$ _____

Amount this Change: Plus ____ Minus _____

New Adjusted Contract Price \$ _____

D. VALIDATION OF CONTRACT MODIFICATION

Dept. of Water Date

Manager & Chief Engineer Date

DISTRIBUTION: Original - Contracting Office c: Contractor

CONTRACT MODIFICATION FORM (EXHIBIT L)

EXHIBIT M – AS BUILT INFORMATION REQUIRED
AS-BUILT INFORMATION REQUIRED

A. As-built information for Waterlines

1. Note any changes in alignment and grade.
 - a. Reference alignment change to baseline or original waterline alignment.
2. Note the cover and existing waterlines (when exposed) and at connection areas.
3. Note the brand and model no. of the following:
 - a. Fire Hydrants
 - b. Valves
 - c. A.C. pipe
 - d. D.I. pipe
 - e. Backflow Preventers (also note down the serial number)
4. Count the number of turns required to open each valve.
 - a. Note this down in the as-builts and write in the date that this was checked.
5. Reference the location of all valves.
 - a. Use the best available reference points.
 - b. If a power pole is used, note down the pole number.
 - c. Use at least two (2) reference points per valve
 - d. Examples of reference points.
 - i. Fire hydrant
 - ii. Water meter box
 - iii. ARV box
 - iv. Cleanout box
 - v. Power pole
 - vi. Street light base
 - vii. Guy wire anchor
 - viii. Street Monument
 - ix. Corner of catch basin
 - x. Drainage structures
 - xi. Manhole Cover
 - xii. Street Signs
 - xiii. Bridge abutments
 - xiv. Corner of a building
 - xv. Any reasonably permanent object
6. Reference hydrant valves to at least two (2) other reference points in addition to the distance from the hydrant head.
 - a. If the hydrant gets knocked down by a vehicle and doesn't get replaced until later, and in the meantime, if the State or County repaves the roadway and the roadway and the hydrant bury gets overgrown with vegetation, Operations can locate the hydrant valve by measuring from the reference points.

AS-BUILT INFORMATION REQUIRED (EXHIBIT M)

B. As-built information for Service Laterals

1. When a new service lateral is installed away from the property corners, measure the distance from the nearest property corner to the meter box.
2. When the existing service laterals are not located at the property corners, measure the distance from the nearest property corner to the existing meter boxes.
 - a. Write down the meter numbers for the existing meter(s).
3. Measure the distance from the angle valve to the waterline at cul-de-sacs and along curves
4. Detector Checks and Compound Meter Laterals
 - a. Verify that the meter spool cannot flow water through the lateral.

C. As-built Drawing Information for Pumping Stations

1. Depth to bottom of well
 - a. Usually measured with a bailer
2. Depth of static water level
 - a. Use well sounder
3. Length and diameter of discharge columns installed
4. Length of pump bowls
5. Length of strainer
6. Location of the bottom of the airline
 - a. Usually placed at the top of the pump coupling
 - b. The bottom of the airline should be beveled at a 45-degree angle
7. Pump data
 - a. Brand, serial number, model number, number of stages.
8. Take meggar readings when installing submersible pumps
9. Motor data
 - a. Write down the nameplate data and space heater serial number on the as-built plans
10. Record the nameplate data for:
 - a. Booster pumps
 - b. Chlorinator booster pumps
 - c. Air compressors

D. As-built Information for Water Tanks

1. Reference the location of the splices along the water stop.

EXHIBIT N – BMP INSPECTION FORM

Department of Water
County of Kauai
Lihue, Kauai, Hawaii

Site Specific Construction Best Management Practices Inspection Form

Job No.: _____ Water Plan 2020 No.: _____ NGPC File No.: _____

Project Title: _____

Date: ____/____/____ Weather: _____

DOW Inspector: _____

Duly Authorized Representative: _____ Contractor: _____

Site Specific Construction Best Management Practices (SSCBMPs) Plan	Yes	No	N/A	Date Corrected	Notes*
Is a copy of the SSCBMP plan available at the site?					
Is the SSCBMP plan certified, signed and dated?					
Is the SSCBMP pan current and up-to-date?					
Are accompanying erosion and sediment control (ESC) drawings available at the site?					
Are the ESC drawings up-to-date?					
Are all NGPCs available at the site?					
Are inspection records available at the site?					

Best Management Practices	Location	Installed per Specification (Y/N)	Adequate	Needs maintenance	N/A	Date Corrected	Notes*
Storm Water Run On (SSCBMP Section 3.1)							
Vegetated Diversion Ditches							
Soil Stabilization (SSCBMP Section 3.2)							
n/a							

Best Management Practices	Location	Installed per Specification (Y/N)	Adequate	Needs maintenance	N/A	Date Corrected	Notes*
Slope Protection (SSCBMP Section 3.3)							
Erosion Control Mats							
Storm Drain Inlet Protection (SSCBMP Section 3.4)							
Mulch socks at all active inlets							
Perimeter Controls and Sediment Barriers (SSCBMP Section 3.5)							
Silt Fence							
Mulch socks							
Sediment Basins and Detention Ponds (SSCBMP Section 3.6)							
Sed Basin							
Stabilized Ingress/Egress (SSCBMP Section 3.7)							
Stabilized egress							
Signage for entrance only							
Signage for exit only							
Additional Erosion and Sediment Control BMPs (SSCBMP Section 3.8)							
Mirafi over soil stockpile							
Material Handling and Waste Management (SSCBMP Section 3.9)							

Bins for Trash							
Baseyards/Staging Areas (SSCBMP Section 3.10)							
Store paint/resin/plaster in container							
Silt Fence							
Wash out Areas (SSCBMP Section 3.11)							
Concrete Washout Container							
Concrete Washout Container							
Proper Equipment/Vehicle Fueling and Maintenance Practices (SSCBMP Section 3.12)							
Lined pit under diesel tank							
Spill kit next to diesel tank							
Additional Non-Erosion or Sediment Control BMPs (SSCBMP Section 3.13)							

Best Management Practices	Location	Installed per Specification (Y/N)	Adequate	Needs maintenance	N/A	Date Corrected	Notes*
Post Construction BMPs (SSCBMP Section 3.14)							
Other							

* Attached additional sheet for notes if necessary

Site Conditions	Yes	No	N/A	Notes and Corrective Actions
-----------------	-----	----	-----	------------------------------

Are Off-site flows entering the construction site?				
Is there evidence of polluted discharges off the site?				
Is there evidence of polluted discharges from the site to a state water (e.g. storm drain, ditch, stream, ocean)?				
Is repair, maintenance, or installation of sediment control BMPs needed at the site?				
Is repair, maintenance, or installation of erosion control BMPs needed at the site?				
Are construction materials/debris/trash/soil stored or disposed of properly on site?				
Is there vehicle tracking from the site to receiving streets?				
Do locations exist where additional or revised BMPs are needed?				
Do locations exist where BMPs may no longer be necessary and may be removed?				
Does your site evaluation indicate a need to update or revise the current SSCBMP plan and/or accompanying erosion and sediment control drawings?				

Pictures taken during the SSCBMP inspection documented above are attached.

YES

NO

I certify under penalty of law that this document and all attachments were prepared under my direction or supervision in accordance with a system designed to assure that qualified personnel properly gather and evaluate the information submitted. Based on my inquiry of the person or persons who manage the system, or those persons directly responsible for gathering the information, the information submitted is, to the best of my knowledge and belief, true, accurate, and complete. I am aware that there are significant penalties for submitting false

information, including the possibility of fine and imprisonment for knowing violations.

Duly Authorized Representative Printed Name

Duly Authorized Representative Signature Date

* Duly Authorized Representative as submitted to DOH for NPDES permit

As an inspector, acting on behalf of the Department of Water, County of Kauai, I certify, to the best of my knowledge and belief, that the inspection verified the compliance of the approved and/or amended site specific BMP plan. All other requirements of the NPDES permit approval are the sole responsibility of the contractor, who is the independent contractor, hired to act as a duly authorized representative of the Kauai Department of Water, and I shall not be personally liable for any violations to the approved permit conditions.

DOW Inspector Printed Name

DOW Inspector Signature Date

EXHIBIT O – EMPLOYMENT OF STATE RESIDENTS COMPLIANCE FORM

**CERTIFICATION OF COMPLIANCE
FOR
EMPLOYMENT OF STATE RESIDENTS
ACT 68, SESSION LAWS OF HAWAII 2010**

Project Title: _____

Agency Project No.: _____

Contract No.: _____

As required by Act 68, Session Laws of Hawai'i 2010-Employment of State Residents on Construction Procurement Contracts, I hereby certify under oath, that I am an officer of _____ and for the month of _____, 20____, _____ is in compliance with Act 68, SLH 2010, by employing a workforce of whom not less than eighty percent are Hawai'i residents, as calculated according to the formula in the solicitation, to perform this Contract.

- I am an officer of the **Contractor** for this contract.
- I am an officer of a **Subcontractor** for this contract.

CORPORATE SEAL

(Name of Company)

(Signature)

(Print Name)

(Print Title)

Subscribed and sworn to me before this ____ day of _____, 20____.

Doc. Date: _____ # Pages: _____

Name of Notary: _____, ____ Circuit

Notary Public, ____ Circuit, State of Hawai'i

Doc. Description: _____

My Commission Expires: _____

Notary Signature Date

NOTARY CERTIFICATION

EMPLOYMENT OF STATE RESIDENTS COMPLIANCE FORM (EXHIBIT O)

EXHIBIT P – REQUEST FOR INFORMATION (RFI) FORM

RFI

To: Dustin Moises, P.E.
Kauai Department of Water
4398 Pua Loke Street
Lihue, HI 96766

RFI #:
Date:
Job No.:
Contractor Phone:
Contractor email:

CC:

Subject:

Drawing Sheet #:
Specification Section:
Cost Impact:
Schedule Impact:

Request:
Requested by: _____
Date response required: _____

Response:
Answered by: _____
Company: _____
Date: _____

REQUEST FOR INFORMATION (RFI) FORM (EXHIBIT P)

Contractor _____

OFFER

For

DEPARTMENT OF WATER, COUNTY OF KAUA‘I,
LĪHU‘E, KAUA‘I, HAWAI‘I

_____ 20 _____

Manager and Chief Engineer
Department of Water
County of Kaua‘i
4398 Pua Loke Street
Līhu‘e, Hawai‘i 96766

Dear Sir:

Pursuant to and in compliance with your Invitation For Bids and other Contract Documents relating thereto, the undersigned Offeror, having familiarized itself with the terms of the contract, the local conditions affecting the performance of the contract and the cost of the work at the place where the work is done, the plans and specifications, “General Provisions for Construction Contracts of the Department of Water”, “Water System Standards, 2002”, Invitation For Bids, and other Contract Documents, hereby proposes and agrees to perform, within the time stipulated in the said documents, including all its component parts and everything required to be performed, and to provide and furnish any and all of the labor, materials, tools, expendable equipment, and all utility and transportation services necessary to perform the contract, in a workmanlike manner, in place complete all of the work covered by the contract in connection with these specifications and accompanying construction plans titled:

[JOB NO. **19-03 Makaleha On-Site Sodium Hypochlorite Generation Pilot Project**, KAUA‘I,
HAWAI‘I]

on file in the office of the Department of Water for,

TOTAL SUM OFFER _____ DOLLARS
(words)

(\$ _____) said total sums being itemized on the following pages:



OFFER SCHEDULE

[JOB NO. **19-03**, KAUA'I, HAWAII]

ITEM NO.	ESTIMATED QUANTITY	DESCRIPTION		UNIT PRICE	TOTAL
1	1 (LS)	On-Site Sodium Hypochlorite Generation System per provided specifications including installation. (OSG Unit includes water softener, brine tank, cartridge filters, acid cleaning system, and low differential pressure switch.)		\$ _____	\$ _____
2	1 (LS)	Startup and testing of new OSG.		\$ _____	\$ _____
3	16 (HR)	Training of DOW personnel (2 days).		\$ _____	\$ _____
4	1 (LS)	Spare parts per specifications.		\$ _____	\$ _____
5	1 (EA)	Sodium Hypochlorite Storage Tank per provided specifications.		\$ _____	\$ _____
6	1 (EA)	Storage Tank Level Transmitter per provided specifications.		\$ _____	\$ _____
7	2 (EA)	Sodium Hypochlorite Metering Pump per provided specifications.		\$ _____	\$ _____
8	1 (LS)	Hydrogen Dilution Blower and Hydrogen Detector per provided specifications.		\$ _____	\$ _____
			TOTAL SUM OFFER (Items 1 to 8 inclusive)		\$ _____



SCHEDULE B
HAWAI'I PRODUCTS PREFERENCE

In accordance with HRS §103D-1002, the Hawai'i products preference is applicable to this solicitation. Hawai'i Products ("HP") are available for those items noted on Schedule B, below. The Hawai'i products list is available on the SPO webpage at www.spo.hawaii.gov/for-state-county-personnel/manual/procurement/solicitation/goods-services-construction/preferences/hawaii-product-preferences/ or go to the SPO Home page, click on "For Vendors" tab; click on Preferences, Hawai'i Product Preferences to view. Offeror transmitting a Hawai'i Product (HP) shall identify the HP on Schedule B-1.

Any person desiring a Hawai'i product preference shall have the product(s) certified and qualified if not currently on the Hawai'i products list, prior to the deadline for receipt of offer(s) specified in the procurement notice and solicitation. The responsibility for certification and qualification shall rest upon the person requesting the preference. Persons desiring to qualify their product(s) not currently on the Hawai'i product list shall complete form SPO-038, Certification for Hawai'i Product Preference and submit, via email to the Procurement Officer issuing the solicitation, and provide the solicitation number and title in the subject line, and include all additional information required by the Procurement Officer. For each product, one form shall be completed and transmitted (i.e. 3 products should have 3 separate forms completed). Form SPO-038 is available on the SPO webpage at <http://hawaii.gov/spo> under the 'Quicklinks' menu; click on 'Forms for Vendors, Contractors, and Service Providers'.

When a solicitation contains both HP and non-HP, then for the purpose of selecting the lowest bid or purchase price only, the price offered for a HP item shall be decreased by subtracting 10% for the class I or 15% for the class II HP items offered, respectively. The lowest total offer, taking the preference into consideration, shall be awarded the contract unless the offer provides for additional award criteria. The contract amount of any contract awarded, however, shall be the amount of the price offered, exclusive of the preferences.

Change in Availability of Hawai'i product. In the event of any change that materially alters the Offeror's ability to supply Hawai'i products, the Offeror shall notify the Procurement Officer in writing no later than five (5) working days from when the Offeror knows of the change and the parties shall enter into discussions for the purposes of revising the contract or terminating the contract for convenience.

The following is a list of products that the Department anticipates will be used in this particular project; however the list is not all inclusive and additional products may be qualified.

HAWAI'I PRODUCTS LIST

HP Description	Manufacturer/Supplier	Class
----------------	-----------------------	-------



Bidders intending to use or supply a Hawai'i Product must list the price and total cost of each item f.o.b. jobsite, unloaded, including applicable general excise tax and use tax on this form. Failure to designate a Hawai'i product will mean that the Bidder is offering a non-Hawai'i product and award, if made to the bidder, will be on the basis that the bidder will deliver or use a non-Hawai'i product.

The Bidder shall list only the Manufacturers/Suppliers certified and qualified on Schedule B.

If the Department has awarded a contract under HRS, § 103D-1002, finds that in the performance of that contract there has been a failure to comply with HRS, § 103D-1002, the contract shall be voidable and the findings shall be referred for debarment or suspension proceedings under HRS 103D-702. Any purchase made or any contract awarded or executed in violation of this section shall be void and no payment shall be made by the Department on account of the purchase or contract.



SCHEDULE B-1
SCHEDULE OF MATERIAL COST
(if Hawai'i preference requested)

HAWAI'I PRODUCT	MANUFACTURER	CLASS	APPROX. QUANTITY	UNIT	TOTAL COST OF MATERIAL
Aggregates and Sand – Basalt, rock, cinder, limestone and coral					
Aggregates – Recycled asphalt and concrete					
Asphalt and paving materials					
Cement and concrete products					
Pre-cast concrete products					
Signs–traffic, regulatory and construction					
Soil amendments, mulch, compost					



SCHEDULE C
MANDATORY LICENSING REQUIREMENT

“A” general engineering contractors and “B” general building contractors are reminded that due to the Hawai‘i Supreme Court’s January 28, 2002 decision in Okada Trucking Co., Ltd. V. Board of Water Supply, et al., 97 Haw. 450 (2002), they are prohibited from undertaking any work, solely or as part of a larger project, that would require the general contractor to act as a specialty contractor in any area in which the general contractor has no license. Although the “A” and “B” contractor may still submit an offer on and act as the “prime” contractor on an “A” and “B” project (*See, HRS § 444-7 for the definitions of an “A” and “B” project.*), respectively, the “A” and “B” contractor may only perform work in the areas in which they have the appropriate “C” specialty contractor’s license (*An “A” or “B” contractor obtains “C” specialty contractor’s licenses either on its own, or automatically under HAR § 16-77-32.*). The remaining work must be subcontracted out to appropriately licensed “C” specialty contractors. It is the sole responsibility of the contractor to review the requirements of this project and determine the appropriate licenses that are required to complete the project.

LISTING OF SUBCONTRACTORS

Sec. 103D-302, H.R.S., provides that each offer for Public Works Construction Contracts shall include the name of each person or firm to be engaged by the Offeror as a joint contractor or subcontractor in the performance of the Public Works Construction Contract. The Offer shall also indicate the nature and scope of the work to be performed by such joint contractors or subcontractors. All offers which do not comply with this requirement shall be rejected pursuant to Sec. 103D-302(b) H.R.S.

To comply with the above provisions, the offeror shall complete the schedule of the nature and scope of work by listing, where applicable, the names of the joint contractors and subcontractors to be used after the description of the nature and scope of the work.

ALL JOINT CONTRACTORS OR SUBCONTRACTORS TO BE ENGAGED ON THIS PROJECT

The Offeror certifies that the following is a complete listing of all joint contractors and/or subcontractors who will be engaged by the Offeror on this Project to perform the nature and scope of work indicated **regardless of the percentage of the value of the work to be performed by the joint contractor or subcontractor**, pursuant to Section 103D-302, Hawai‘i Revised Statutes, and understands that failure to comply with this requirement shall be just cause for rejection of the Offer.

The Offeror further understands that only those joint contractors or subcontractors listed shall be allowed to perform work on this Project. If no joint contractor or subcontractor for any subdivision of work is listed, it shall be construed that the work shall be performed by the Offeror with Offeror’s employees.

All Offerors must be sure that they possess, and that the joint contractors or subcontractors listed in the Offer possess, all the necessary specialty licenses needed to perform the work for this Project. The Offeror shall be solely responsible for assuring that all specialty licenses required to perform the work is covered in the Offer.

The Offeror shall include the license number of the joint contractors or subcontractors listed below. Failure to provide the correct names and license numbers as registered with the Contractors Licensing Board may cause rejection of the offer submitted.

It is the sole responsibility of the contractor to review the requirements of this Project and determine the appropriate licenses that are required to complete the Project.

LISTING OF ALL JOINT CONTRACTORS OR SUBCONTRACTORS

	Contractor Classification	Name of Joint Contractor or Subcontractor	License Number
C-1	Acoustical and Insulation Contractor		
C-2	Mechanical Insulation Contractor		
C-3	Asphalt Paving and Surfacing Contractor		
C-3a	Asphalt Concrete Patching, Sealing, and Striping Contractor		
C-3b	Play Court Surfacing Contractor		
C-4	Boiler, Hot-Water Heating and Steam Fitting Contractor		
C-5	Cabinet, Millwork, and Carpentry Remodeling and Repairs Contractor		
C-5a	Garage Door and Window Shutters Contractor		
C-5b	Siding Application Contractor		
C-6	Carpentry Framing Contractor		
C-7	Carpet Laying Contractor		
C-9	Cesspool Contractor		
C-10	Scaffolding Contractor		
C-12	Drywall Contractor		
C-13	Electrical Contractor		
C-14	Sign Contractor		
C-15	Electronic Systems Contractor		
C-15a	Fire and Burglar Alarm Contractor		
C-15b	Telecommunications Contractor		
C-16	Elevator Contractor		
C-16a	Conveyor Systems Contractor		
C-17	Excavating, Grading, and Trenching Contractor		
C-19	Asbestos Contractor		
C-20	Fire Protection Contractor		
C-20a	Fire Repressant Systems Contractor		



	Contractor Classification	Name of Joint Contractor or Subcontractor	License Number
C-21	Flooring Contractor		
C-22	Glazing and Tinting Contractor		
C-22a	Glass Tinting Contractor		
C-23	Gunite Contractor		
C-24	Building Moving and Wrecking Contractor		
C-25	Institutional and Commercial Equipment Contractor		
C-27	Landscaping Contractor		
C-27a	Hydro Mulching Contractor		
C-27b	Tree Trimming and Removal Contractor		
C-31	Masonry Contractor		
C-31a	Cement Concrete Contractor		
C-31b	Stone Masonry Contractor		
C-31c	Refractory Contractor		
C-31d	Tuckpointing and Caulking Contractor		
C-31e	Concrete Cutting, Drilling, Sawing, Coring, and Pressure Grouting Contractor		
C-32	Ornamental, Guardrail, and Fencing Contractor		
C-32a	Wood and Vinyl Fencing Contractor		
C-33	Painting and Decorating Contractor		
C-33a	Wall Coverings Contractor		
C-33b	Taping Contractor		
C-33c	Surface Treatment Contractor		
C-34	Soil Stabilization Contractor		
C-35	Pile Driving, Pile and Caisson Drilling, and Foundation Contractor		
C-36	Plastering Contractor		
C-36a	Lathing Contractor		
C-37	Plumbing Contractor		



	Contractor Classification	Name of Joint Contractor or Subcontractor	License Number
C-37a	Sewer and Drain Line Contractor		
C-37b	Irrigation and Lawn Sprinkler Systems Contractor		
C-37c	Vacuum and Air Systems Contractor		
C-37d	Water Chlorination and Sanitation Contractor		
C-37e	Treatment and Pumping Facilities Contractor		
C-37f	Fuel Dispensing Contractor		
C-38	Post Tensioning Contractor		
C-40	Refrigeration Contractor		
C-40a	Prefabricated Refrigerator Panels Contractor		
C-41	Reinforcing Steel Contractor		
C-42	Roofing Contractor		
C-42a	Aluminum and Other Metal Shingles Contractor		
C-42b	Wood Shingles and Wood Shakes Contractor		
C-42c	Concrete and Clay Tile Contractor		
C-42e	Urethane Foam Contractor		
C-42g	Roof coatings Contractor		
C-43	Sewer, Sewage Disposal, Drain, and Pipe Laying Contractor		
C-43a	Reconditioning and Repairing Pipeline Contractor		
C-44	Sheet Metal Contractor		
C-44a	Gutters Contractor		
C-44b	Awnings and Patio Cover Contractor		
C-48	Structural Steel Contractor		
C-48a	Steel Door Contractor		
C-49b	Hot Tub and Pool Contractor		
C-51	Tile Contractor		

	Contractor Classification	Name of Joint Contractor or Subcontractor	License Number
C-51a	Cultured Marble Contractor		
C-51b	Terrazzo Contractor		
C-52	Ventilating and Air Conditioning Contractor		
C-55	Waterproofing Contractor		
C-56	Welding Contractor		
C-57	Well Contractor		
C-57a	Pumps Installation Contractor		
C-57b	Injection Well Contractor		
C-60	Solar Power Systems Contractor		
C-61	Solar Energy Systems Contractor		
C-61a	Solar Hot Water Systems Contractor		
C-61b	Solar Heating and Cooling Systems Contractor		
C-62	Pole and Line Contractor		
C-62a	Pole Contractor		
C-63	High Voltage Electrical Contractor		
C-68	Classified Specialist		
	Licensed Surveyor		
	Licensed Geotechnical Engineer		
	Licensed Structural Engineer		
	Archaeologist		
	Cultural Monitor		
	Licensed Civil Engineer		
	Supervising Control and Data Acquisition (SCADA) Contractor		
*			
*			
*			
*			
*			



	Contractor Classification	Name of Joint Contractor or Subcontractor	License Number
*			

* Contractor to add licenses as required to complete the scope of work. Attach additional sheet as needed. It is understood and agreed that the Department reserves the right to reject any and/or all offers and waive any defects when, in the Department’s opinion, such rejection or waiver shall be for the best interest of the Department.

For purpose of evaluating the criterion described in this solicitation, it is understood and agreed that offers will be compared on the basis of the Total Sum Offer which shall be considered to be the total sum of actual or corrected amounts proposed on each item. The offerors signed Offer shall constitute the Offeror’s official offer. The Department reserves the right to designate the contract amount based on selected Offeror’s Total Sum Offer depending on the funds available for this Project.

It is also understood and agreed that the work called for under this Project must and shall be completed within **ONE HUNDRED EIGHTY (180)** consecutive calendar days after written notice has been given to the successful Offeror to commence work. It is also understood and agreed that the quantities given herewith are approximate only and are subject to increase or decrease and that the undersigned will perform all quantities of work, as either increase or decrease, in accordance with the provisions of the specifications.

It is also understood and agreed that the estimated quantities shown for items for which a UNIT PRICE is listed in the Offer are only for the purpose of comparing on a uniform basis offers offered for the work under this contract, and the undersigned agrees that the undersigned is satisfied with and will not dispute said estimated quantities as a means of comparing the offers. It is understood and agreed that the Offeror will make no claims for anticipated profit or loss of profit because of a difference between quantities of the various classes of work done or the materials and equipment actually installed and the said estimated quantities. On UNIT PRICE offers, payment will be made only for the actual number of units incorporated into the finished project at the contract UNIT PRICE.

It is also understood and agreed that if the product of the UNIT PRICE offer and the number of units does not equal the total amount stated by the Offeror in the offer for any item, it will be assumed that the error was made in computing the total amount. For purpose of evaluating the criterion described in this solicitation, the stated UNIT PRICE alone will be considered as representing the Offeror’s intention and the total amount offered on such item shall be considered to be the amount arrived at by multiplying the UNIT PRICE by the number of units.

It is also understood and agreed that the liquidated damages in the amount of **TWO HUNDRED FIFTY AND 00/100 DOLLARS (\$250.00)** for each and every calendar day in excess thereof prior to completion of the contract beyond the specified and approved completion date, shall be withheld from payments due to the Contractor, pursuant to the Damages for Delay provision contained in this solicitation.

It is also understood and agreed that if this offer is accepted, the successful offeror will contract with the Board and said offeror shall furnish the required bonds to the Board within ten (10) days from the date of receiving from the Board the contract prepared and ready for execution.

It is further understood and agreed that the successful offeror will provide all necessary materials, labor, tools, equipment, and other incidental necessary to do all the work and furnish all the materials specified in the contract in the manner and time herein prescribed and according to the requirements of the Department as therein set forth.



The undersigned further understands and agrees that by submitting this Offer, 1) the Offeror is declaring that the Offer is not in violation of Chapter 84, Hawai'i Revised Statutes, and 2) Offeror is certifying that the price(s) submitted was (were) independently arrived at without collusion.

It is also understood and agreed that if this Offer is accepted and the undersigned shall fail to or neglect to contract as aforesaid, the Board may determine that the offeror has abandoned the contract and thereupon forfeiture of the security accompanying the Offer shall operate and the same shall become the property of the Board.

Enclosed herewith is a Bidder's Bond (Bid Security)	()	for the sum
Surety Bond	()	
Legal Tender	()	
Certificate of Deposit	()	
Share Certificate	()	
Cashier's Check	()	
Treasurer's Check	()	
Teller's Check	()	
Certified Check	()	

of _____ DOLLARS
(\$ _____) payable to the Department of Water, being not less than the sum required under Sub-Section 2.9 "Bid Security" of the "General Provisions for Construction Contracts of the Department of Water", dated April 25, 2016.

Evidence of the undersigned Offeror having the authority to submit this Offer and to enter a contract is herewith furnished.

Respectfully submitted,

Name of Offeror

Authorized Signature

Print/Type Name & Title of above

Address, Zip Code

Telephone

Contractor's License No.

State of Hawai'i General Excise Tax License No.

Federal Employer Identification No.

Type of Organization: (Please designate)

- Sole Proprietorship Partnership
 Corporation Joint Venture
 Other (*please specify*) _____

State of Incorporation: Hawai'i Other (*please specify*) _____

Name of Performance Bond Surety Co. _____

Address _____

Authorized to do Business in the State of Hawai'i? Yes or No

If corporation, state who will sign contract and signatory's title:

Name

Title



Name

Title

If the Offeror is a **CORPORATION**, the legal name of the corporation shall be set forth on the Offer, together with the signature(s) of the Officer(s) authorized to sign on behalf of the corporation and the corporate seal affixed thereto. Evidence of the authority of the Officer(s) to sign on behalf of the Corporation **SHALL** be attached to this page and included in the Offer. Acceptable evidence of authority to sign includes, but is not limited to, a copy of the articles of incorporation, corporate resolution, or corporate by-laws. (See HRS Ch. 415, Hawai'i Business Corporation Act).

If the Offeror is a **LIMITED LIABILITY COMPANY**, the legal name of the company shall be set forth on the Offer, together with the signature(s) of the member of the limited liability company or manager of the manger-managed limited liability company authorized to sign on behalf of the entity. Evidence of the authority of the Officer(s) authorized to sign on behalf of the company **SHALL** be attached to this page and included in the Offer.

If the Offeror is a **PARTNERSHIP**, the legal name of the firm shall be set forth on the Offer, together with the signature(s) of the General Partner(s) authorized to sign on behalf of the partnership. Evidence of the authority of the General Partner(s) authorized to sign on behalf of the partnership **SHALL** be attached to this page and included with the Offer. Acceptable evidence of authority to sign for the partnership includes, but is not limited to, a copy of the partnership registration statement or authorization signed by all of the partners. (See HRS Ch. 425, Partnerships).

If Offeror is a SOLE PROPRIETORSHIP, Offeror's signature shall be placed above.



EXHIBIT D
INSURANCE REQUIREMENTS
BOARD OF WATER SUPPLY, COUNTY OF KAUA'I

Contractor shall procure and maintain, on primary basis and at its sole expense, at all times during the life of the contract insurance coverages, limits, including endorsements described herein against claims for injuries to persons or damages to property which may arise from or in connection with the performance of the work by the Contractor or the Contractor's agents, representatives, employees or subcontractors. The requirements contained herein, as well as the Department of Water, County of Kaua'i's (hereinafter "DOW") review or acceptance of insurance maintained by the Contractor is not intended to and shall not in any manner limit or qualify the liabilities or obligations assumed by the Contractor.

To the extent applicable, the amounts and types of insurance will conform to the minimum terms, conditions and coverage(s) of Insurance Service Office (ISO) policies, forms, and endorsements.

A. General Conditions

Waiver of Subrogation. Contractor shall agree by entering into a contract with the Board of Water Supply, County of Kaua'i (hereinafter "Board") to provide a Waiver of Subrogation for the Commercial General Liability, Automobile Liability, and Workers Compensation policies. When required by the insurer, or should a policy condition not permit Contractor to enter into a pre-loss agreement to waive subrogation without an endorsement, the Contractor shall agree to notify the insurer and request the policy be endorsed with a Waiver of Subrogation in favor of the Board. This Waiver of Subrogation requirement shall not apply to any policy, which includes a condition specifically prohibiting such an endorsement, or voids coverage should Contractor enter into such an agreement on a pre-loss basis.

Additional Insured. Contractor shall agree to endorse the **BOARD OF WATER SUPPLY, COUNTY OF KAUA'I as an Additional Insured** with a CG026 Additional Insured – Designated Person or Organization endorsement, a copy of the applicable policy language, or similar endorsement to all required insurance policy(ies), except for Workers Compensation and Professional Liability.

Deductibles and Self-Insured Retentions. Any deductibles or self-insured retentions must be declared to and approved by the DOW. At the option of the DOW, either: the insurer shall reduce or eliminate such deductibles or self-insured retentions as respects the Board; or the Contractor shall provide a financial guarantee (audited financial statement) satisfactory to the Department guaranteeing payment of losses and related investigations, claim administration and defense expenses.

When a self-insured retention (SIR) or deductible exceeds \$50,000, the Department reserves the right, but not the obligation, to review and request a copy of the Contractor's most recent annual report or audited financial statement.

Contractor's Responsibility. The Contractor is responsible for paying any portion of any loss not covered because of the operation of any deductible, co-insurance clause or self-insured retention applicable to the insurance required herein. If the Board is damaged by the failure of the Contractor to maintain insurance as required in this paragraph, then the Contractor shall bear all reasonable costs properly attributable to that failure.

Primary and Non-contributory. All policies required of the Contractor will be endorsed as primary and any insurance or self-insurance program maintained by the Board shall be non-contributory.

Certificate of Insurance. Concurrent with the execution of the contract, Contractor shall provide the Department a certificate of insurance completed by a duly authorized representative of their insurer certifying that the liability coverage(s) is written on an occurrence form. Immediately upon becoming aware that its insurance will be cancelled, non-renewed, or materially changed, Contractor will notify Department by providing written notice.

The Certificate Holder address shall read:

Board of Water Supply, County of Kaua'i
4398 Pua Loke Street, Līhu'e, HI 96766
Attention: Val Reyna
Contract No.: [Click here to enter text.](#)
Project Title: Job No. 19-03 Makaleha On-site Sodium Hypochlorite Generation
Pilot Project

Concurrent with the execution the contract the Contractor shall furnish the Department with original certificates and endorsements effecting required coverage(s). The Department reserves the right to require complete copies of all required insurance policies, including the policy declarations and endorsements affecting the coverage at any time.

Failure to secure and maintain the required insurance shall be considered as a material breach of the contract. Should the Board be forced to expend funds that would have been covered under the specified insurance, Contractor shall reimburse the Board for such funds. In the event the Board determines, in its sole and absolute discretion, that it is necessary to purchase the coverages herein required of the Contractor, and which the Contractor has failed to secure, the Contractor shall reimburse the Board for the expenditure of such funds.

Right to Revise or Reject. Department reserves the right, but not the obligation, to review and revise any insurance requirement, not limited to limits, coverages and endorsements based on insurance market conditions affecting the availability or affordability of coverage; or changes in the scope of work or specifications affecting the applicability of coverage. Additionally, the Department reserves the right, but not the

obligation, to review and reject any insurance policies failing to meet the criteria stated herein or any insurer providing coverage due to its poor financial condition or failure to operate legally.

B. Minimum Insurance Coverage Requirements

Unless otherwise approved by the Manager and Chief Engineer, the policy or policies of insurance maintained by the Contractor shall provide the following minimum limit(s) and coverage(s) as specified herein and be placed with an insurance carrier authorized to do business in the State of Hawai‘i and rated A-VII by A.M. Best:

Commercial General Liability. The Contractor shall procure and maintain Commercial General Liability, with dedicated required limits, as set forth herein, written on occurrence form providing:

- Designated premises basis OR Per Project basis

The coverages shall include the following:

- Premises Operations
- Independent Contractors
- Products and Completed Operations
- Broad Form Property Damage including completed operations
- Blanket Contractual Liability
- Personal Injury
- Employees named as Additional Insured
- Severability of Interest
- Explosion, Collapse and Underground Property Damage

The minimum limits of liability may be satisfied by providing either:

<p>Bodily Injury and Property Damage Combined Single Limit:</p> <ul style="list-style-type: none"> • \$2,000,000 per occurrence • \$2,000,000 annual aggregate 	<p>OR</p>	<p>Personal Injury:</p> <ul style="list-style-type: none"> • \$1,000,000 per occurrence • \$2,000,000 annual aggregate <p style="text-align: center;">AND</p> <p>Products and Completed Operations:</p> <ul style="list-style-type: none"> • \$1,000,000 per occurrence • \$2,000,000 annual aggregate
---	------------------	---

Contractor must provide evidence the Board is an Additional Insured for Products/Completed Operations coverage for both ongoing operations and after

substantial completion of the work. This coverage may be provided by the ISO form CG 2010 (11 85) or an equivalent policy form. Coverage provided by a non-equivalent CGL form shall be specifically endorsed providing both the course of construction and products/completed operations. ISO CG 2010 (04 13) and ISO form CG 2037 (04 13) or an equivalent form is required from the Contractor. The Contractor and subcontractor(s), if any, shall provide evidence to the Department on an annual basis the products/completed operation coverage is in effect for two (2) years after substantial completion of the project.

Business Automobile Liability. The Contractor shall procure and maintain Business Automobile Liability written on occurrence form for all Owned, Non-owned, and Hired automobiles. If the Contractor does not own automobiles, Contractor shall agree to maintain coverage for Hired & Non-Owned Auto Liability, which may be satisfied by way of endorsement to the Commercial General Liability policy or separate Business Automobile Liability. Coverage shall be for automobile contractual liability, uninsured and underinsured motorist coverage, basic no-fault, and personal injury protection, as required by Hawaii law with the following limits:

Bodily Injury

\$1,000,000 per person
\$1,000,000 per occurrence

Property Damage

\$1,000,000 per accident

Workers' Compensation and Employer's Liability. The Contractor shall procure and maintain at all times during the term of the contract the following insurance liability coverage: Workers' Compensation, Temporary Disability Insurance (TDI), and similar insurance that is required by the State of Hawaii or federal laws. Self-insurance is permitted subject to submission of a copy of the appropriate governmental authorization and qualification by the Contractor and subcontractor(s).

The minimum limits of liability to be maintained are as follows:

Coverage A: State of Hawaii Workers' Compensation Law:

Statutory Limits

Coverage B: Employer's Liability:

Bodily Injury from each accident	\$1,000,000
Bodily Injury from disease	\$1,000,000
Bodily Injury from disease aggregate	\$1,000,000

Builder's Risk. The Contractor shall procure and maintain an Inland Marine Builder's Risk policy providing coverage to protect the interests of the Board, Contractor, sub-contractors, architects, and engineers, including property in transit and property on or off-premises, which shall become part of the building, or Project. Coverage shall be written on an **All Risk, Replacement Cost, and Completed Value Form** basis in an amount at least equal to 100% of the projected completed value of the Project as well as subsequent modifications of that sum, unless an agreed amount is otherwise stated between the Department and the Contractor. The policy shall insure all work, labor, and materials furnished by the Contractor and the Contractor's subcontractors against loss occasioned by fire, lightning, windstorm, theft, vandalism, malicious mischief, flood, earthquake, and collapse.

The amount of coverage for the perils of flood and earthquake may be subject to a sub-limit. The sub-limit shall provide coverage of at least 25% of the full replacement cost.

The policy shall also include coverage for debris removal and reasonable compensation for architect's and engineer's services and expenses required as a result of an insured loss. The Contractor shall endorse the policy with a manuscript endorsement eliminating the automatic termination of coverage in the event the building is occupied in whole or in part, or put to its intended use, or partially accepted by the Department. The manuscript endorsement shall amend the automatic termination clause to only terminate coverage if the policy expires, is cancelled, the Board's interest in the building ceases, or the building is accepted or insured by the Board.

The Contractor shall name the Board of Water Supply, County of Kaua'i as a loss payee on the Builder's Risk policy.

Installation Floater. The Contractor shall procure and maintain an Installation Floater policy providing coverage to protect the interests of the Board, Contractor, sub-contractor(s), architects, and engineers, including property in transit and property on or off-premises, which shall become part of the project.

Coverage shall be written on an All Risk, Replacement Cost, and Completed Value Form basis in an amount at least equal to 100% of the projected completed value of the Project as well as subsequent modifications of that sum, unless an agreed amount is otherwise stated between the Department and the Contractor. The policy shall insure all work, labor, and materials furnished by the Contractor and the Contractor's subcontractors against loss occasioned by fire, lightning, windstorm, theft, vandalism, malicious mischief, flood, earthquake, and collapse.

The amount of coverage for the perils of flood and earthquake may be subject to a sub-limit. The sub-limit shall provide coverage of at least 25% of the full replacement cost.

The policy shall also include coverage for debris removal and reasonable compensation for architect's and engineer's services and expenses required as a result of an insured loss. The Contractor shall endorse the policy with a manuscript endorsement eliminating

the automatic termination of coverage in the event the building is occupied in whole or in part, or put to its intended use, or partially accepted by the Department. The manuscript endorsement shall amend the automatic termination clause to only terminate coverage if the policy expires, is cancelled, the Board's interest in the building ceases, or the building is accepted or insured by the Board.

The Contractor shall name the Board of Water Supply, County of Kauai as a loss payee on the Installation Floater policy.

Professional Liability (Errors and Omissions). The Contractor and its subcontractors shall procure and maintain Professional Liability Insurance (Errors and Omissions Insurance) that covers all such activities under the contract. Such insurance shall have these minimum limits and coverage(s):

\$1,000,000 per occurrence
\$2,000,000 annual aggregate

For policies written on a "Claims-Made" basis, Contractor warrants the retroactive date equals or precedes the effective date of the contract. In the event the policy is canceled, non-renewed, switched to an Occurrence Form, retroactive date advanced; or any other event triggering the right to purchase a Supplemental Extended Reporting Period (SERP) during the life of the contract, Contractor shall agree to purchase Supplement Extended Reporting Period (SERP) with a minimum reporting period not less than two (2) years. The requirement to purchase a SERP shall not relieve Contractor of the obligation to provide replacement coverage.

Pollution Legal Liability. The Contractor shall procure and maintain Pollution Liability or similar Environmental Impairment Liability at a minimum limit not less than:

\$1,000,000 per occurrence
\$2,000,000 annual aggregate

The policy shall provide coverage for damages against, but not limited to, third-party liability, clean-up, corrective action including assessment, remediation and defense costs.

Contractor's Pollution Liability. Contractor shall procure and maintain pollution liability insurance when the Scope of Work involves removal, abatement, encapsulation or other treatment, disposal or remediation of asbestos or other hazardous materials or an exposure to pollutants or impairment of the environment. The policy shall provide coverage for third party liability, clean-up, and corrective action including assessment remediation and defense costs. The policy may be written on either an occurrence form or claims made. The minimum limits of liability shall be:

\$1,000,000 per occurrence
\$2,000,000 annual aggregate

Crime Insurance or Commercial Fidelity Bond. Contractor shall procure and maintain Commercial Crime Insurance or Fidelity Bond providing Employee Dishonesty on a blanket basis covering all of the Contractor’s employees with a minimum amount of insurance at least equal to the amount of the contract. The policy shall be endorsed to cover “Third-Party Liability” including a third-party beneficiary clause in favor of the Board. The policy shall include a minimum twelve (12) month “Discovery Period” when written on a Loss Sustained basis.

Property. The Tenant or Lessee, shall agree to maintain property insurance including flood and windstorm written on a replacement cost basis in an amount not less than 100% of the replacement cost of the building(s) and contents, including betterments and improvements made by the Tenant or Lessee, located on the premises. Contractor shall agree to be fully responsible for any deductible or self-insured retention, and to provide this coverage on primary basis.

Umbrella or Excess Liability. Contractor may satisfy the minimum liability limits required above under an Umbrella or Excess Liability policy with \$1,000,000 per occurrence and \$2,000,000 aggregate. If Contractor is using its Umbrella or Excess Liability Insurance policy to satisfy the minimum requirements, Contractor shall agree to endorse the Board of Water Supply, County of Kaua‘i as “Additional Insured” on the Umbrella or Excess Liability policy, or shall confirm in writing that its Umbrella or Excess Liability policy “follows form.”

DEPARTMENT OF WATER

COUNTY OF KAUAI

JOB NO. 85-5

PUMP, CONTROLS, PUMPHOUSE AND CONNECTING PIPELINE FOR MAKALEHA WELL NO.0623-04 KAPAA WATER SYSTEM

KAPAA, KAUAI, HAWAII

TAX MAP KEY 4-6-03

PREPARED BY
AKINAKA & ASSOCIATES, LTD.
CONSULTING ENGINEERS
HONOLULU, HAWAII

INDEX TO DRAWINGS

DESCRIPTION	SHEET NO.
TITLE SHEET	6
CONSTRUCTION NOTES	11
GRADING PLAN	13
SITE PLAN	20 (E-1 TO E-7)
MISCELLANEOUS PROFILES AND DETAILS	
WELL PUMP PIPING DETAILS	
PUMP CONTROL BUILDING AND DETAILS	
BACK PRESSURE VALVE SYSTEM	
ELECTRICAL PLANS	

SHEET NO.
6
11
13
20 (E-1 TO E-7)

APPROVED:

MANAGER & CHIEF ENGINEER, DEPARTMENT OF WATER
COUNTY OF KAUAI

7-1-87
DATE

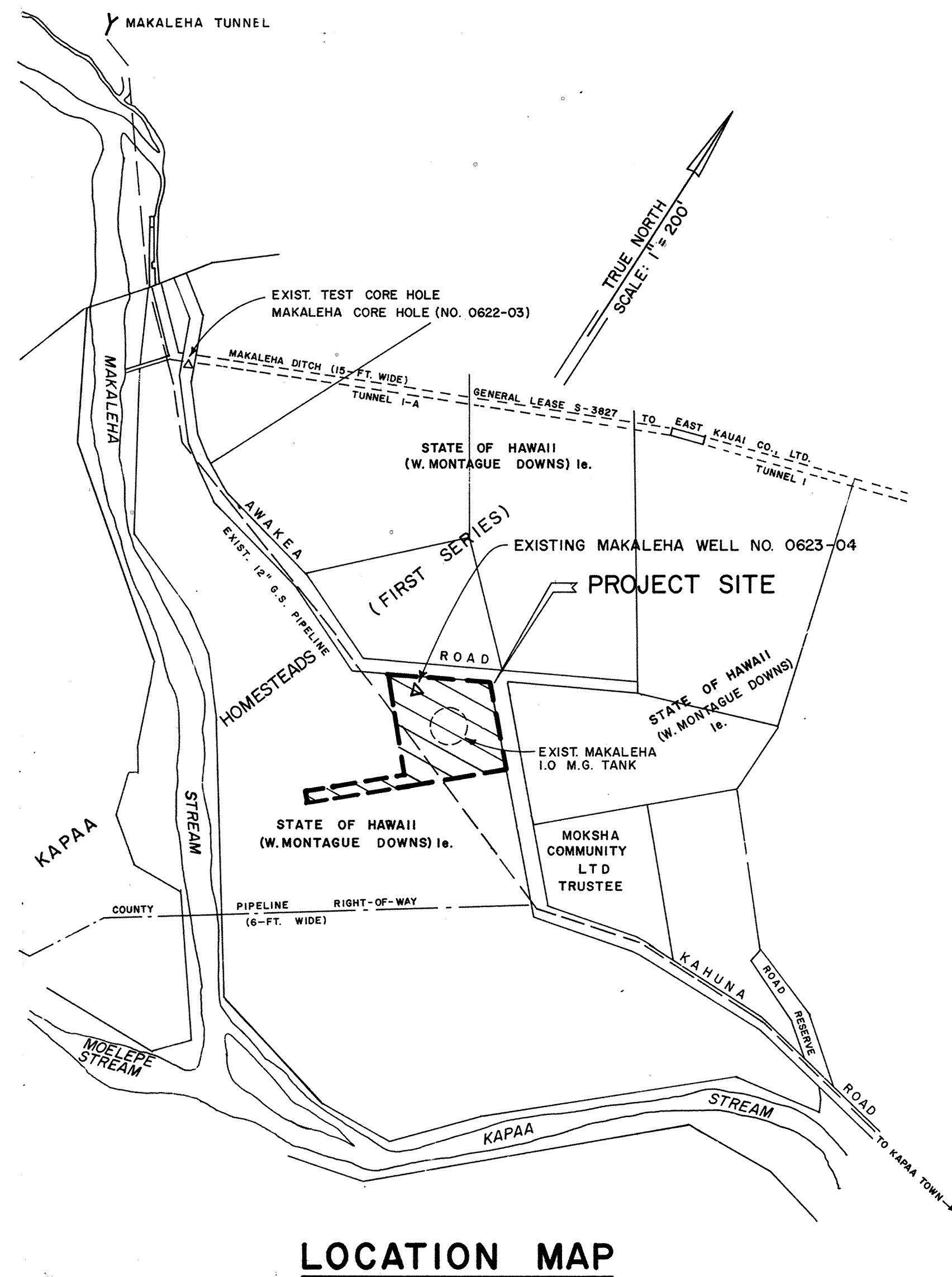
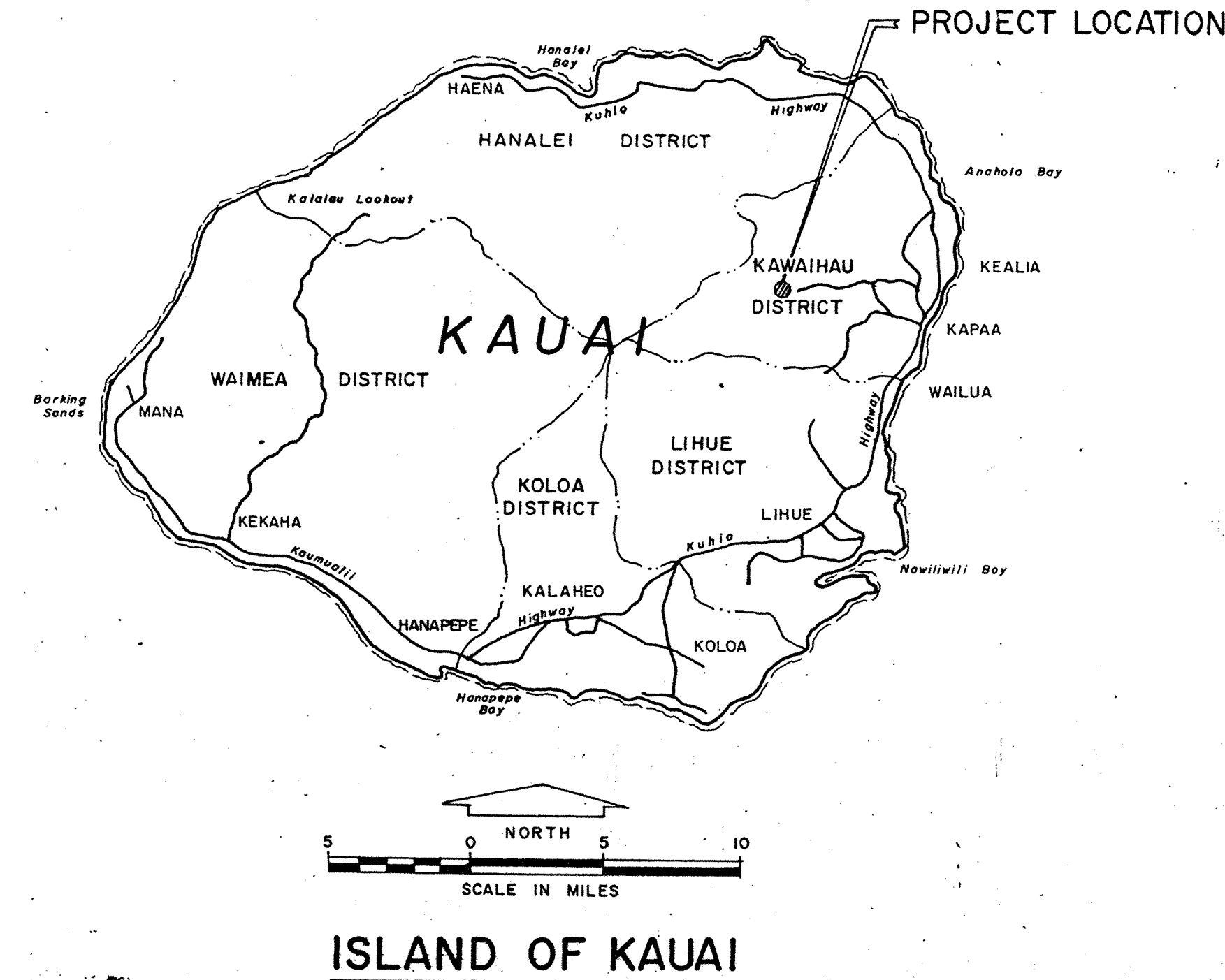

GENERAL CONSTRUCTION NOTES

1. THE STANDARD SPECIFICATIONS FOR PUBLIC WORKS CONSTRUCTION, SEPTEMBER 1986 OF THE DEPARTMENT OF PUBLIC WORKS, COUNTY OF KAUAI, ARE REFERRED TO AND HEREBY MADE A PART OF THIS CONTRACT. THEY SHALL APPLY IN ALL CASES, EXCEPT WHEN MODIFIED BELOW.
2. WHEN NO DETAILS ARE SHOWN, THE CONTRACTOR SHALL USE THE STANDARD DETAILS FOR PUBLIC WORKS CONSTRUCTION, SEPTEMBER 1984, OF THE COUNTY OF KAUAI.
3. ALL EXISTING UTILITIES, WHETHER SHOWN ON THE PLANS OR NOT, SHALL BE PROTECTED AT ALL TIMES UNLESS OTHERWISE NOTED. LOCATIONS OF ALL UNDERGROUND UTILITIES AND PIPES SHOWN ON THE PLANS ARE APPROXIMATE ONLY. THE CONTRACTOR SHALL VERIFY THE EXACT LOCATIONS AND INVERTS OF THE EXISTING UTILITIES AND SHALL BE RESPONSIBLE FOR ANY DAMAGE TO THEM.
4. ANY PORTION OF EXISTING UTILITIES THAT MUST BE REMOVED OR OTHERWISE DISTURBED TO ACCOMPLISH THE WORK CALLED FOR ON THE PLANS SHALL BE RECONSTRUCTED, REPLACED OR RESTORED TO THEIR ORIGINAL CONDITION AT THE CONTRACTOR'S EXPENSE.
5. REPAIR OF DAMAGED PAVEMENT AND SHOULDERS WILL BE INSPECTED AND APPROVED BY THE DEPARTMENT OF PUBLIC WORKS. ANY WORK FOUND TO BE UNACCEPTABLE SHALL BE REWORKED AND CORRECTED AS DIRECTED BY THE COUNTY ENGINEER.

WATER NOTES

1. PIPE SHALL BE DUCTILE IRON, CLASS 52 EXCEPT WHERE SHOWN ON PLANS. ALL FITTINGS FOR DUCTILE IRON PIPES SHALL BE CEMENT MORTAR LINED C.I. CLASS 150.
2. CONTRACTOR SHALL MAKE CONNECTION TO EXISTING MAIN UNDER SUPERVISION OF THE DEPT. OF WATER. CONNECTIONS SHALL BE MADE AT NIGHT BETWEEN THE HOURS OF 8:00 P.M. AND 4:00 A.M. NOTIFY THE DEPT. OF WATER 48 HOURS PRIOR TO CONNECTION.
3. INSTALLATION OF ALL PIPE LINES AND ITS APPURTENANCES SHALL BE IN ACCORDANCE TO THE DEPT. OF WATER REQUIREMENTS AND PROCEDURES.
4. TRENCH EXCAVATION, BACKFILL AND REPAVING TO CONFORM TO THE "STANDARD SPECIFICATIONS FOR PUBLIC WORKS CONSTRUCTION," SEPTEMBER 1986.
5. ALL SPECIAL FITTINGS, PIPES AND OTHER APPURTENANCES SHALL BE PROVIDED AS NECESSARY TO COMPLETE THE INSTALLATION OF THE WATER SYSTEM.
6. THE CONTRACTOR SHALL NOTIFY THE DEPT. OF WATER AT LEAST 24 HOURS PRIOR TO ANY PIPE LAYING, BACKFILLING, TESTING OR CHLORINATION TO INSURE THAT INSPECTION SERVICES WILL BE AVAILABLE.

ENVIRONMENTAL PROTECTION NOTES

1. THE CONTRACTOR SHALL REMOVE ALL SILT AND DEBRIS RESULTING FROM HIS WORK THAT BECOMES DEPOSITED IN DRAINAGE FACILITIES, ROADWAYS OF OTHER AREAS. ANY COST INCURRED FOR NECESSARY REMEDIAL ACTION TAKEN BY THE ENGINEER SHALL BE PAID BY THE CONTRACTOR.
2. THE CONTRACTOR, AT HIS OWN EXPENSE, SHALL KEEP THE PROJECT AREA AND SURROUNDING AREAS FREE FROM DUST NUISANCE. THE WORK SHALL BE DONE IN CONFORMANCE WITH THE AIR POLLUTION CONTROL STANDARDS AND REGULATIONS OF THE STATE DEPARTMENT OF HEALTH.
3. ALL EXCESS MATERIAL SHALL BE REMOVED FROM THE PROJECT SITE PRIOR TO THE FINAL INSPECTION.
4. CONSTRUCTION DEBRIS AND WASTES SHALL BE DEPOSITED AT AN APPROPRIATE SITE. THE CONTRACTOR SHALL INFORM THE COUNTY ENGINEER OF THE LOCATION OF THE DISPOSAL SITES. DISPOSAL SITES SHALL FULFILL THE REQUIREMENTS OF THE COUNTY GRADING ORDINANCE AND THE STATE DEPARTMENT OF HEALTH.

WORK WITHIN COUNTY RIGHT-OF-WAY

1. A PERMIT SHALL BE OBTAINED FROM THE DEPARTMENT OF PUBLIC WORKS, COUNTY OF KAUAI, BEFORE WORK UPON ANY PORTION OF A PUBLIC STREET OR PUBLIC HIGHWAY MAY BEGIN.
2. ALL FINISHED TOP ELEVATIONS FOR MANHOLES, VALVE BOXES, SHALL MATCH THE EXISTING/FINISHED SHOULDER GRADE.
3. DURING NON-WORKING HOURS, ALL TRENCHES SHALL BE COVERED WITH A SAFE NON-SKID BRIDGING MATERIAL.
4. THE CONTRACTOR SHALL TAKE PRECAUTIONARY MEASURES TO PROTECT AND PRESERVE PRIVATE PROPERTY. ANY DAMAGE TO PRIVATE PROPERTY SHALL BE REPAIRED BY THE CONTRACTOR'S OWN EXPENSE AND SHALL MEET THE APPROVAL OF THE OWNER.
5. THE CONTRACTOR SHALL INSTALL, PROVIDE AND MAINTAIN ALL NECESSARY SIGNS, LIGHTS, FLARES, BARRICADES AND OTHER PROTECTIVE FACILITIES AND TAKE ALL THE NECESSARY PRECAUTIONS FOR THE PROTECTION OF THE WORK AND THE CONVENIENCE AND SAFETY OF PUBLIC TRAFFIC. ALL SUCH PROTECTIVE FACILITIES AND PRECAUTIONS TO BE TAKEN SHALL CONFORM WITH THE "RULES AND REGULATIONS GOVERNING THE USE OF TRAFFIC CONTROL DEVICES AT WORK SITES ON OR ADJACENT TO THE PUBLIC STREETS AND HIGHWAYS" AS ADOPTED BY THE STATE HIGHWAYS SAFETY COORDINATOR, AND THE U.S. FEDERAL HIGHWAY ADMINISTRATION'S "MANUAL ON UNIFORM TRAFFIC CONTROL DEVICES FOR STREETS AND HIGHWAYS, PART VI - TRAFFIC CONTROLS FOR HIGHWAY CONSTRUCTION AND MAINTENANCE OPERATIONS," DATED 1978 AND ITS AMENDMENTS.
6. THE BACKFILL MATERIAL OVER THE VAULT FOR THE BACK PRESSURE VALVE SHALL BE TOPSOIL OR SELECT MATERIAL. ALL BARED AREAS SHALL BE GRASSED.

APPROVED:

Thomas M. G... 7/10/87
 COUNTY ENGINEER, DEPT. OF PUBLIC WORKS
 COUNTY OF KAUAI



THIS WORK WAS PREPARED BY
 ME OR UNDER MY SUPERVISION
Ronald T. Yama

REVISION DATE	DESCRIPTION	MADE BY	APPROVED
AKINAKA & ASSOCIATES, LTD. CONSULTING ENGINEERS JOB NO. 85-5 PUMP, CONTROLS, PUMPHOUSE AND CONNECTING PIPELINE FOR MAKALEHA WELL NO. 0623-04 KAPAA WATER SYSTEM KAPAA, KAUAI, HAWAII			
CONSTRUCTION NOTES			
APPROVED: <i>Raymond A. V...</i> MANAGER / CHIEF ENGINEER, DEPT. OF WATER SUPPLY			7-1-87 DATE

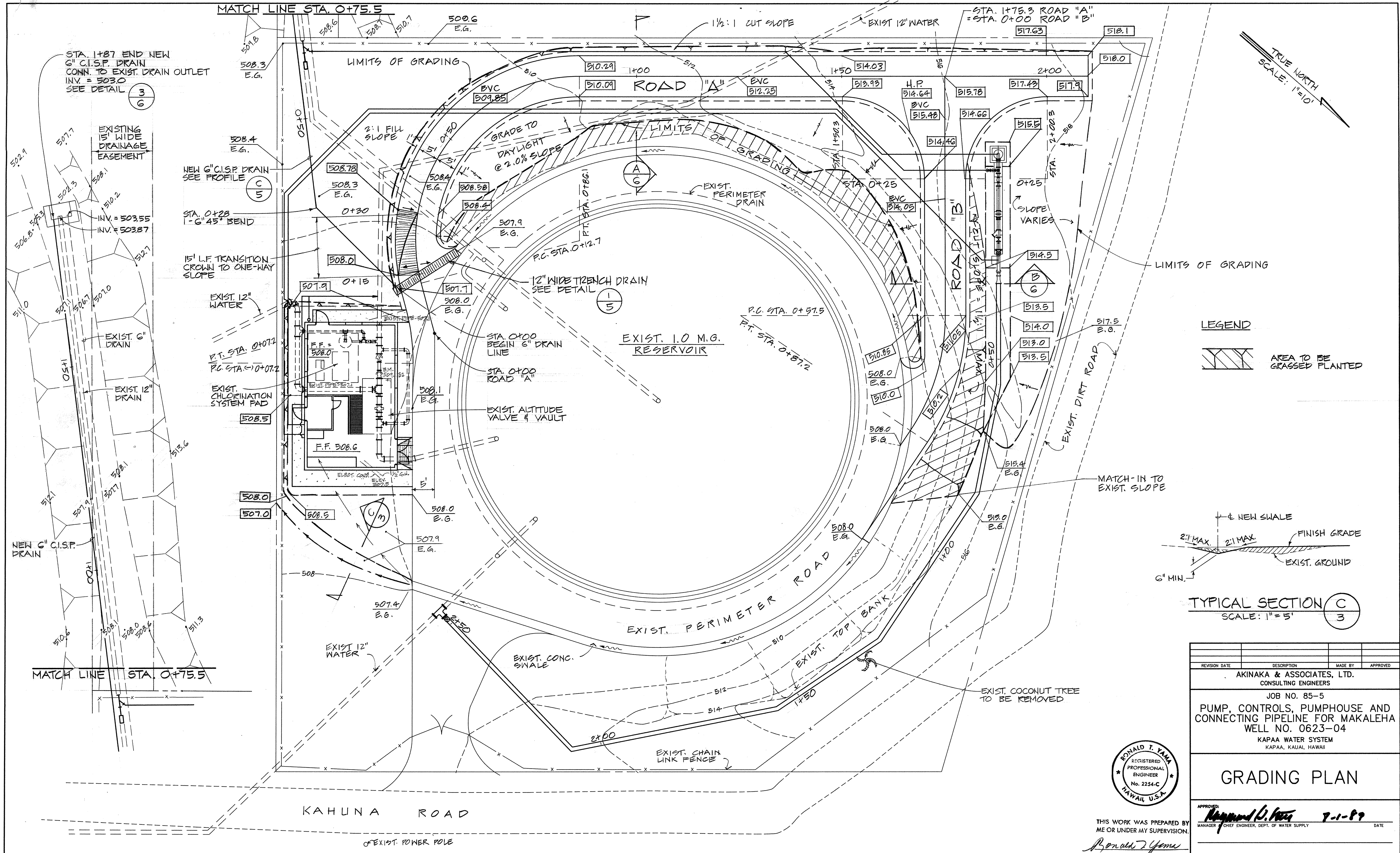

LEGEND
 AREA TO BE GRASSED PLANTED

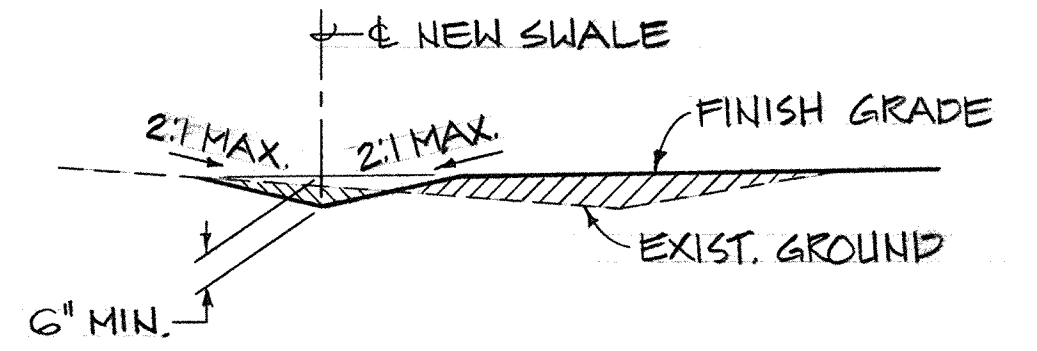

TYPICAL SECTION C
 SCALE: 1"=5'

REVISION DATE	DESCRIPTION	MADE BY	APPROVED
	AKINAKA & ASSOCIATES, LTD. CONSULTING ENGINEERS		
	JOB NO. 85-5 PUMP, CONTROLS, PUMPHOUSE AND CONNECTING PIPELINE FOR MAKALEHA WELL NO. 0623-04 KAPAA WATER SYSTEM KAPAA, KAUAI, HAWAII		

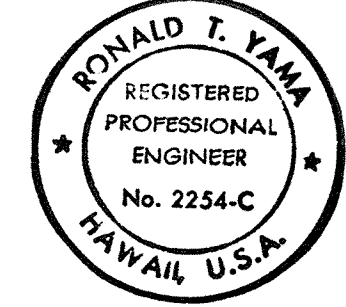

APPROVED: *Ronald T. Yama* 7-1-89
 MANAGER / CHIEF ENGINEER, DEPT. OF WATER SUPPLY
 THIS WORK WAS PREPARED BY ME OR UNDER MY SUPERVISION.
Ronald T. Yama

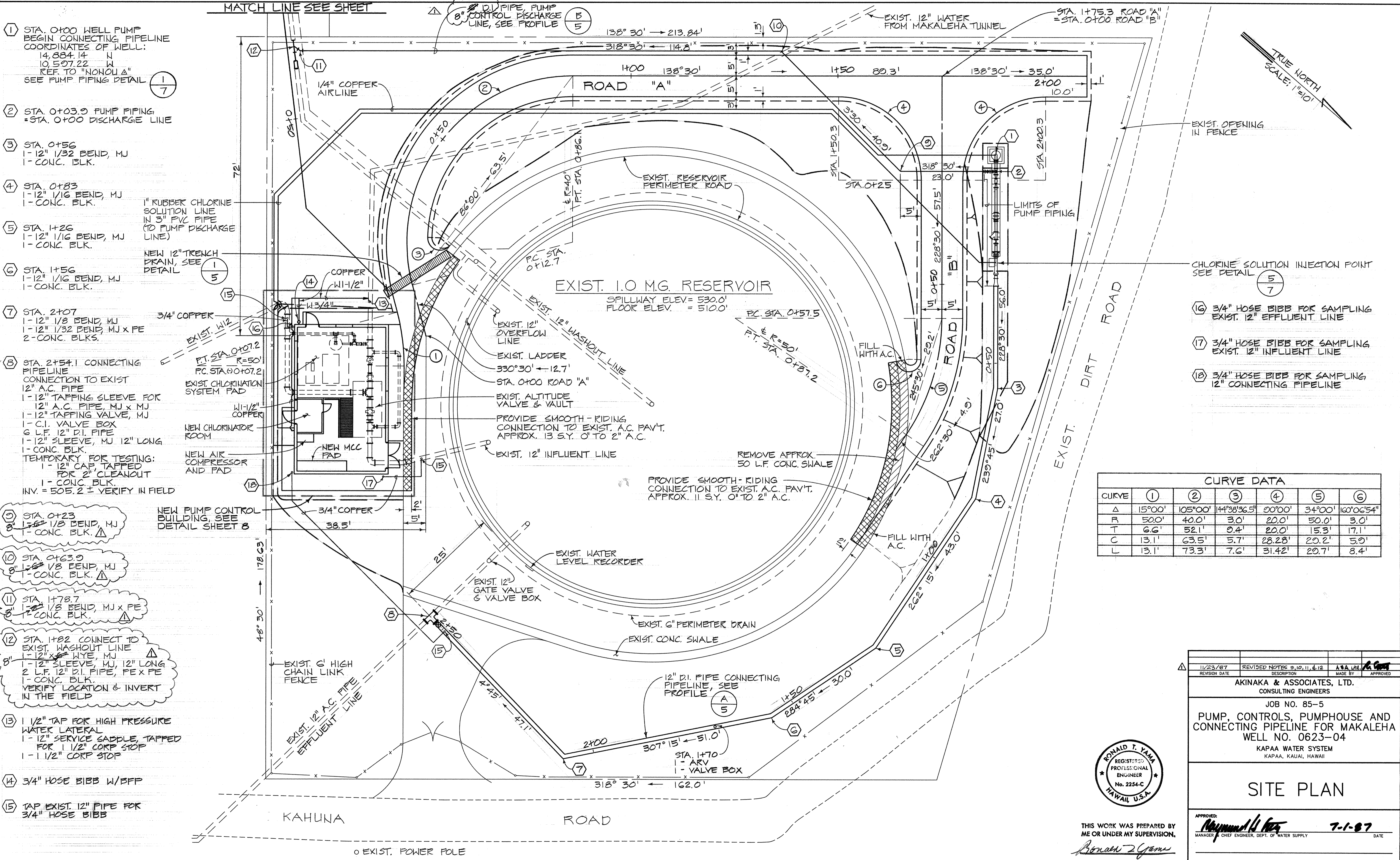

- ① STA. 0+00 WELL PUMP BEGIN CONNECTING PIPELINE COORDINATES OF WELL:
14,884.14 N
10,507.22 W
REF. TO "NONOU A"
SEE PUMP PIPING DETAIL (1/7)
- ② STA. 0+03.9 PUMP PIPING = STA. 0+00 DISCHARGE LINE
- ③ STA. 0+56
1-12" 1/32 BEND, MJ
1-CONC. BLK.
- ④ STA. 0+83
1-12" 1/16 BEND, MJ
1-CONC. BLK.
- ⑤ STA. 1+26
1-12" 1/16 BEND, MJ
1-CONC. BLK.
- ⑥ STA. 1+56
1-12" 1/16 BEND, MJ
1-CONC. BLK.
- ⑦ STA. 2+07
1-12" 1/8 BEND, MJ
1-12" 1/32 BEND, MJ x PE
2-CONC. BLKS.
- ⑧ STA. 2+54.1 CONNECTING PIPELINE CONNECTION TO EXIST 12" A.C. PIPE
1-12" TAPPING SLEEVE FOR 12" A.C. PIPE, MJ x MJ
1-12" TAPPING VALVE, MJ
1-C.I. VALVE BOX
6 L.F. 12" D.I. PIPE
1-12" SLEEVE, MJ 12" LONG
1-CONC. BLK.
TEMPORARY FOR TESTING:
1-12" CAP, TAPPED FOR 2" CLEANOUT
1-CONC. BLK.
INV. = 505.2 ± VERIFY IN FIELD
- ⑨ STA. 0+23
1-12" 1/8 BEND, MJ
1-CONC. BLK.
- ⑩ STA. 0+63.9
1-12" 1/8 BEND, MJ
1-CONC. BLK.
- ⑪ STA. 1+78.7
1-12" 1/8 BEND, MJ x PE
1-CONC. BLK.
- ⑫ STA. 1+82 CONNECT TO EXIST. WASHOUT LINE
1-12" WYE, MJ
1-12" SLEEVE, MJ, 12" LONG
2 L.F. 12" D.I. PIPE, PE x PE
1-CONC. BLK.
VERIFY LOCATION & INVERT IN THE FIELD
- ⑬ 1 1/2" TAP FOR HIGH PRESSURE WATER LATERAL
1-12" SERVICE SADDLE, TAPPED FOR 1 1/2" CORP STOP
1-1 1/2" CORP STOP
- ⑭ 3/4" HOSE BIBB W/BFP
- ⑮ TAP EXIST. 12" PIPE FOR 3/4" HOSE BIBB

- ⑯ CHLORINE SOLUTION INJECTION POINT SEE DETAIL (5/7)
- ⑰ 3/4" HOSE BIBB FOR SAMPLING EXIST. 12" EFFLUENT LINE
- ⑱ 3/4" HOSE BIBB FOR SAMPLING EXIST. 12" INFLUENT LINE
- ⑳ 3/4" HOSE BIBB FOR SAMPLING 12" CONNECTING PIPELINE

CURVE DATA

CURVE	①	②	③	④	⑤	⑥
Δ	15°00'	105°00'	144°38'36.5"	20°00'	34°00'	160°06'54"
R	500'	40.0'	3.0'	20.0'	50.0'	3.0'
T	6.6'	52.1'	0.4'	20.0'	15.3'	17.1'
C	13.1'	63.5'	5.7'	28.28'	20.2'	5.0'
L	13.1'	73.3'	7.6'	31.42'	20.7'	8.4'

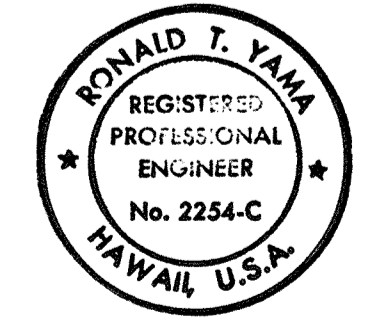

THIS WORK WAS PREPARED BY ME OR UNDER MY SUPERVISION.
Ronald T. Yama
 MANAGER / CHIEF ENGINEER, DEPT. OF WATER SUPPLY

11/23/87	REVISED NOTES 9, 10, 11, & 12	AKA L34	APPROVED
REVISION DATE	DESCRIPTION	MADE BY	APPROVED
AKINAKA & ASSOCIATES, LTD. CONSULTING ENGINEERS			
JOB NO. 85-5 PUMP, CONTROLS, PUMPHOUSE AND CONNECTING PIPELINE FOR MAKALEHA WELL NO. 0623-04 KAPAA WATER SYSTEM KAPAA, KAUAI, HAWAII			
SITE PLAN			
APPROVED:	<i>Raymond H. King</i>	7-1-87	DATE
MANAGER / CHIEF ENGINEER, DEPT. OF WATER SUPPLY			

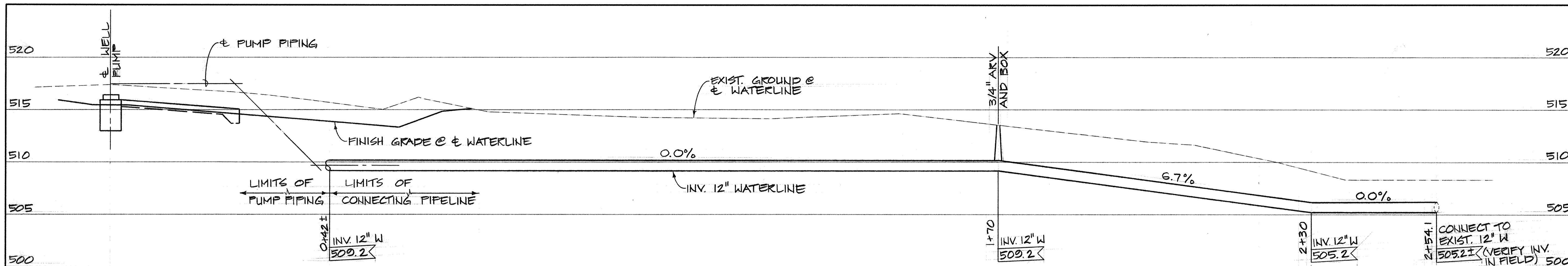

PROFILE - 12" CONNECTING PIPELINE (A)
 SCALE: HORIZ. 1"=10' VERT. 1"=5'

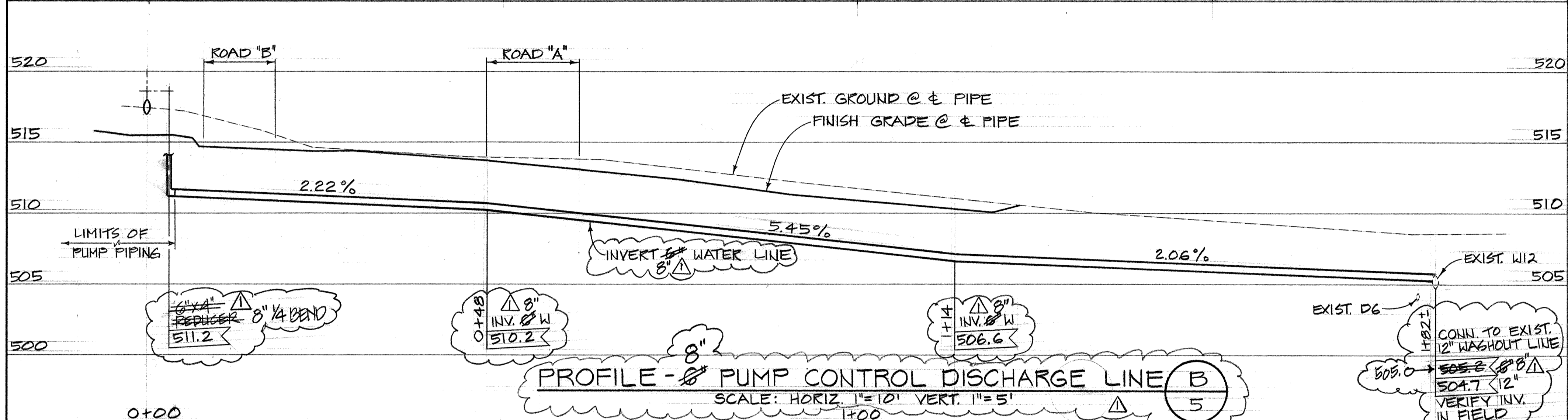

PROFILE - 8" PUMP CONTROL DISCHARGE LINE (B)
 SCALE: HORIZ. 1"=10' VERT. 1"=5'

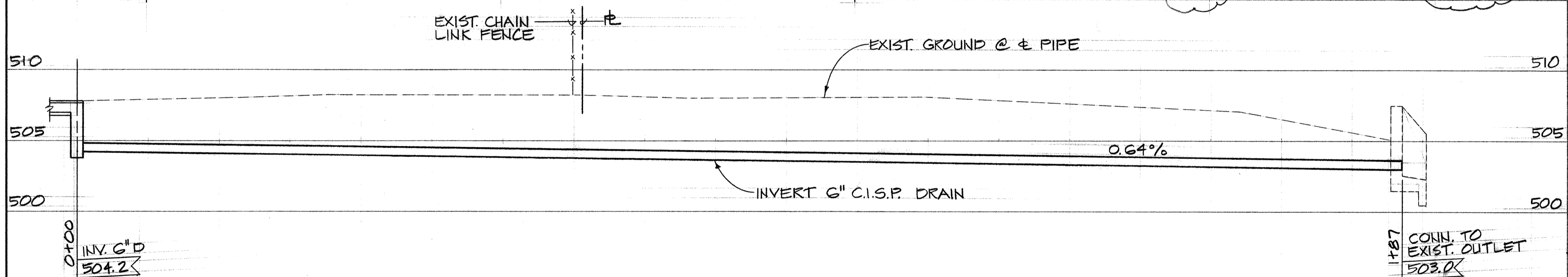

PROFILE - 6" C.I.S.P. DRAIN (C)
 SCALE: HORIZ. 1"=10' VERT. 1"=5'

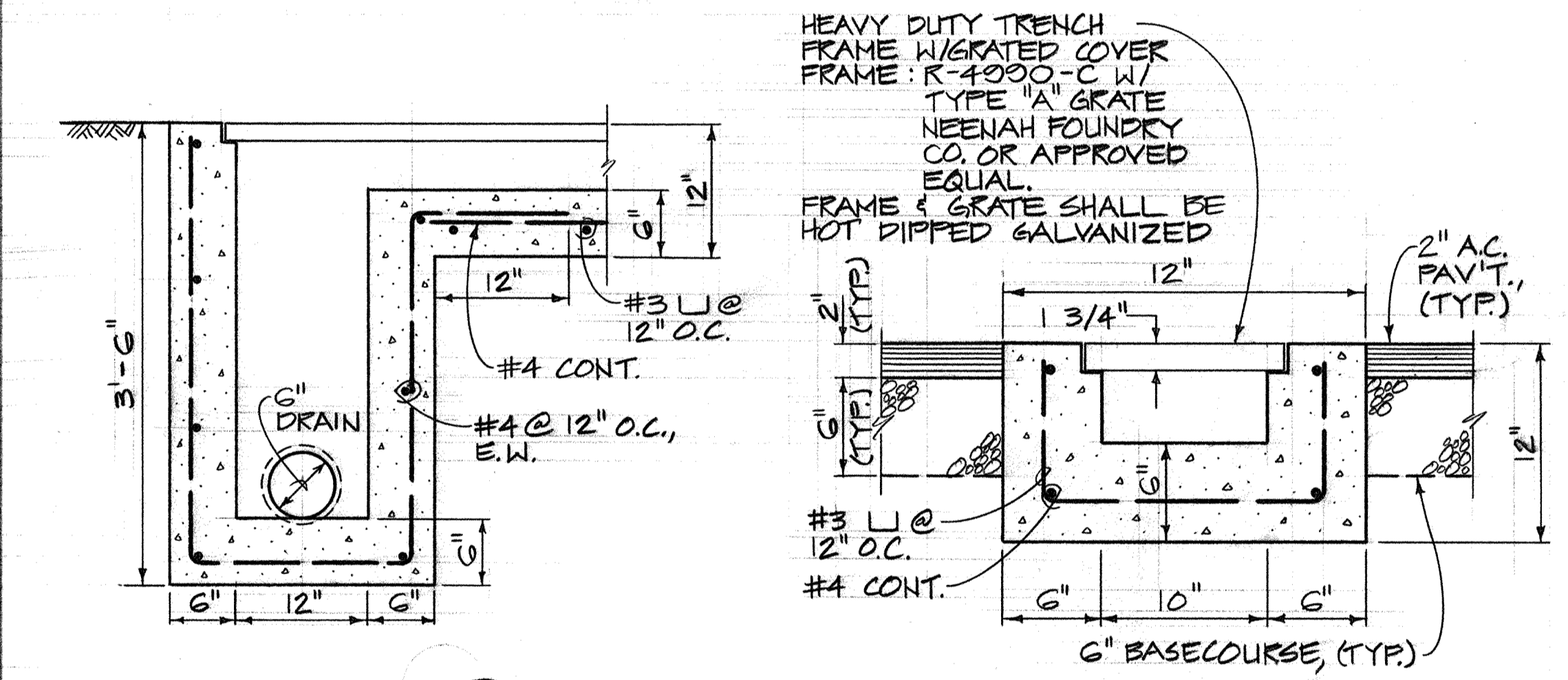
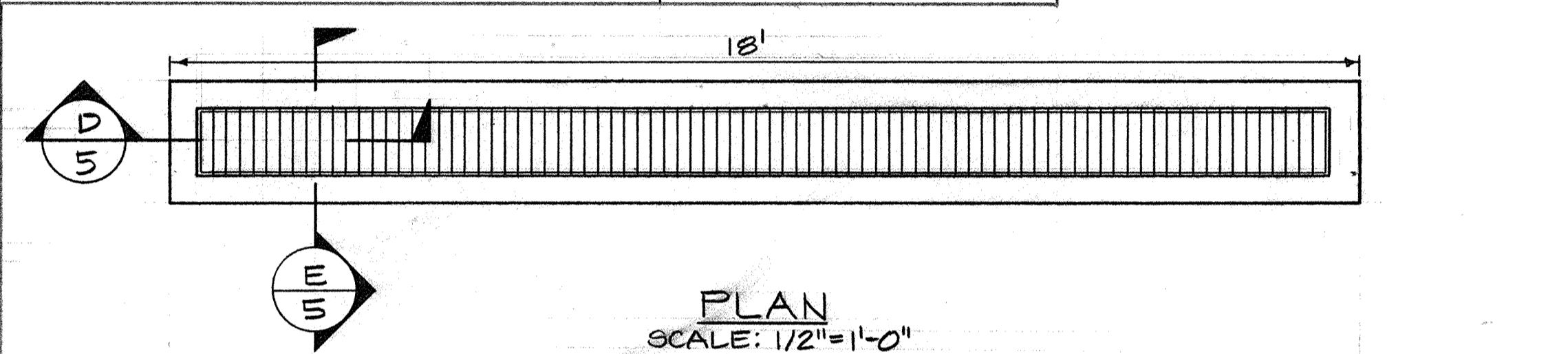

TRENCH DRAIN DETAIL (1)
 SCALE AS SHOWN

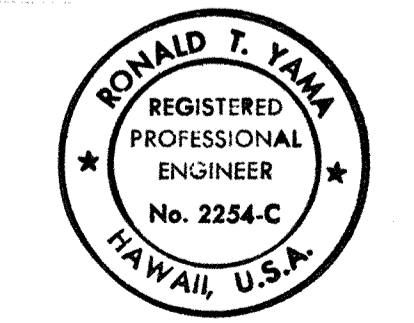
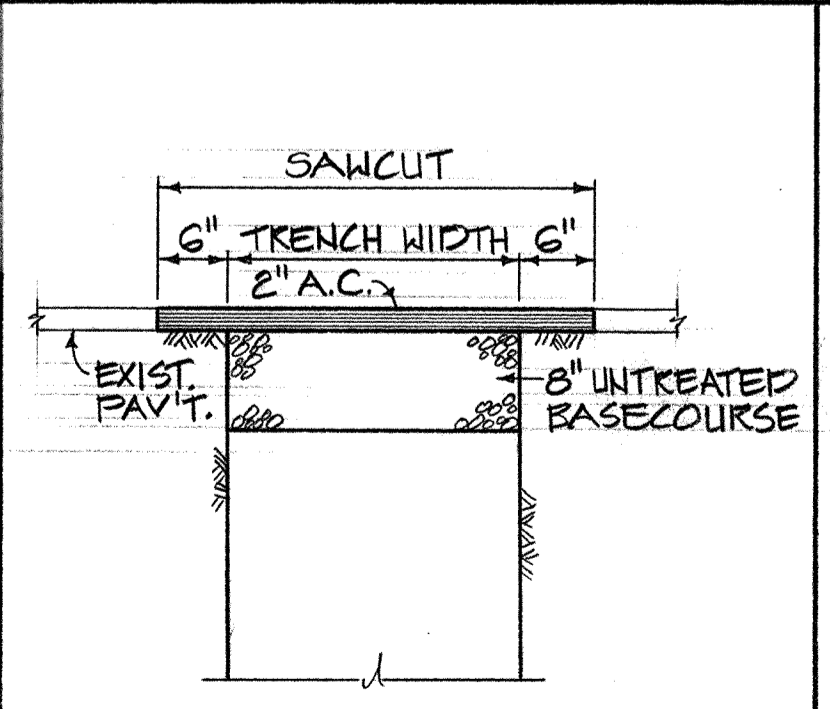

THIS WORK WAS PREPARED BY ME OR UNDER MY SUPERVISION.
Ronald T. Yam

11/23/67	REVISE PROFILE - 8" PUMP CONTROL DISCHARGE LINE	A.S.A., L.L.C.	APPROVED
REVISION DATE	DESCRIPTION	MADE BY	APPROVED
AKINAKA & ASSOCIATES, LTD. CONSULTING ENGINEERS JOB NO. 85-5 PUMP, CONTROLS, PUMPHOUSE AND CONNECTING PIPELINE FOR MAKALEHA WELL NO. 0623-04 KAPAA WATER SYSTEM KAPAA, KAUAI, HAWAII			
MISCELLANEOUS PROFILES & DETAILS			
APPROVED: <i>Raymond D. Gies</i> MANAGER / CHIEF ENGINEER, DEPT. OF WATER SUPPLY			7-1-87 DATE

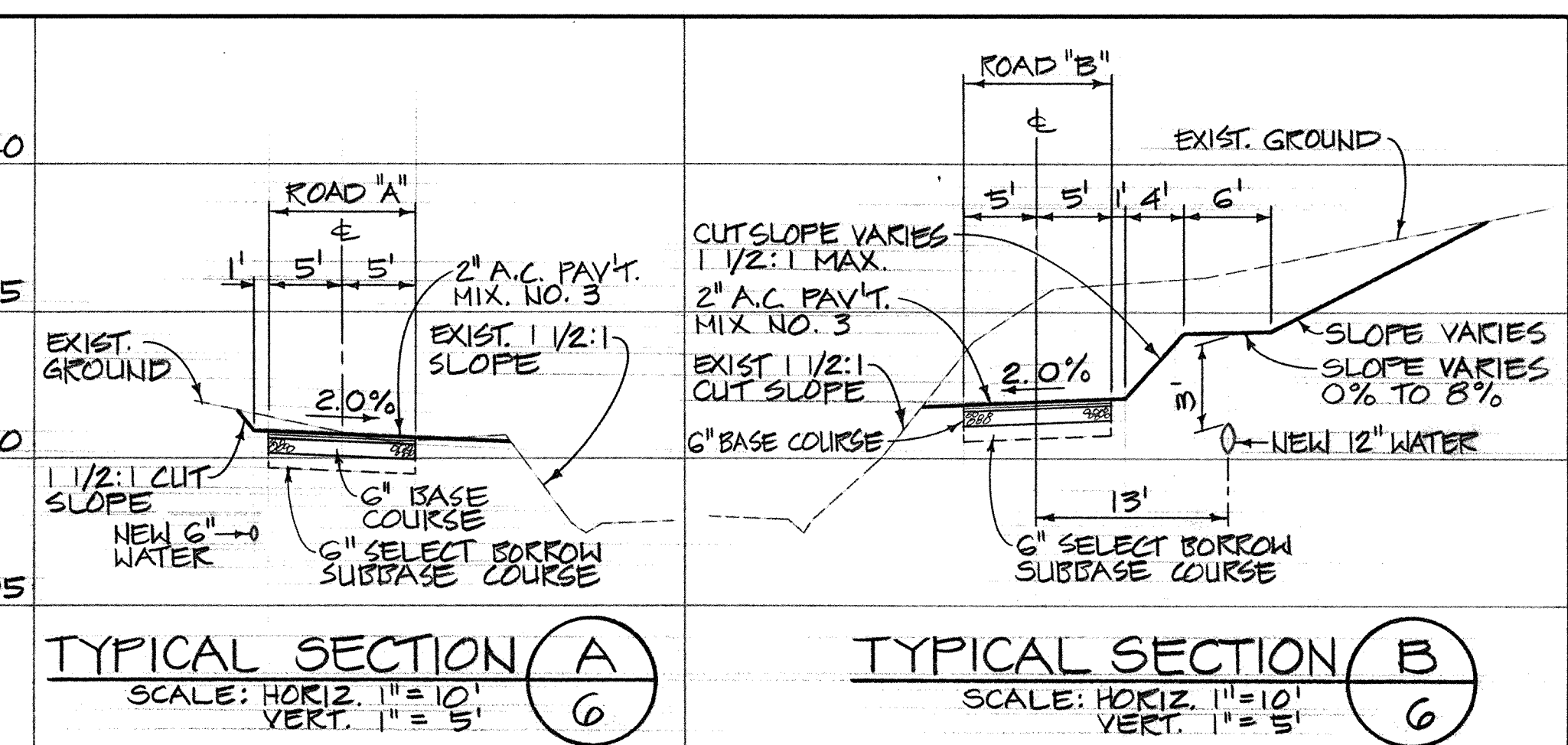
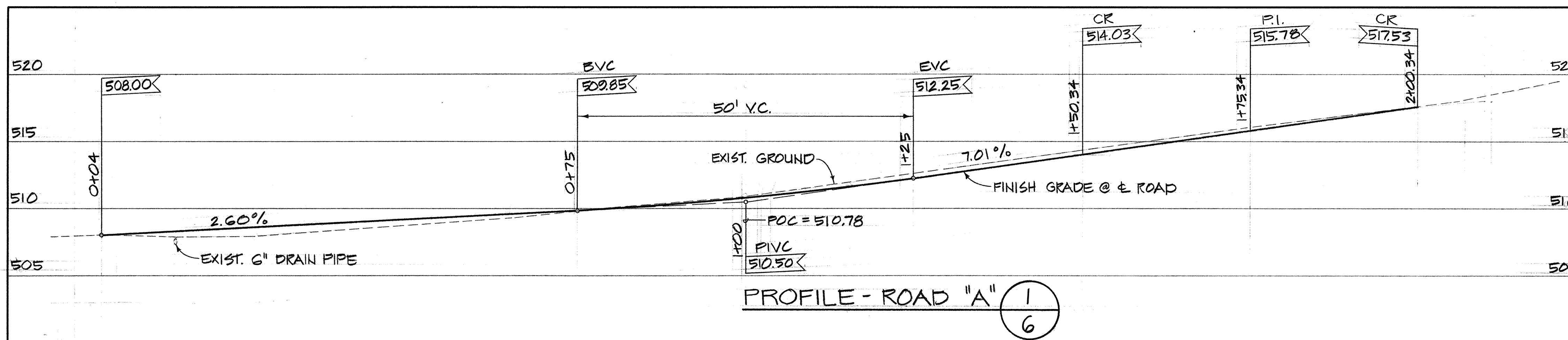

NOTE: ALL 1 1/2:1 SLOPES SHALL BE GRASSED. SEE GRADING PLAN.

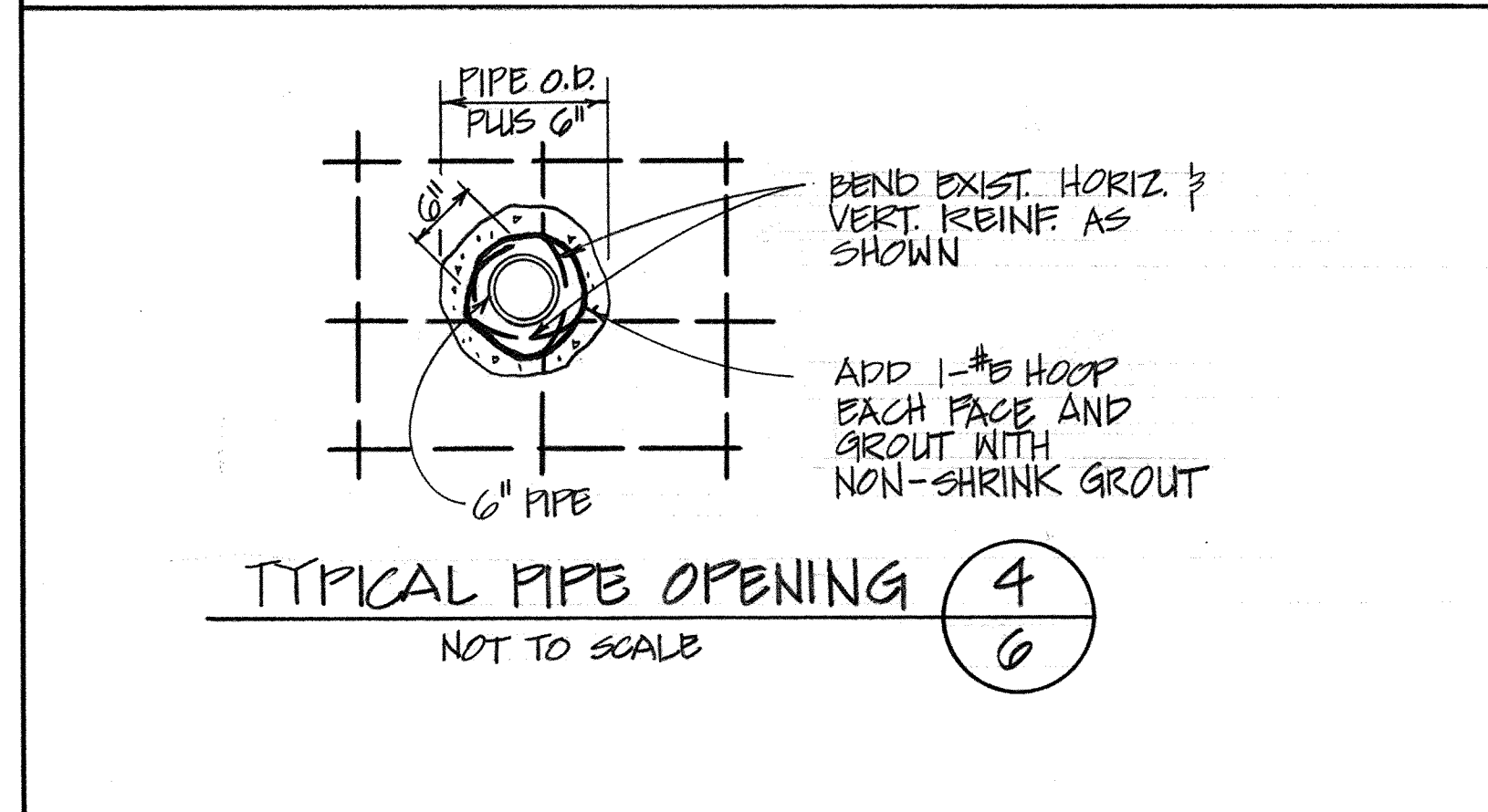
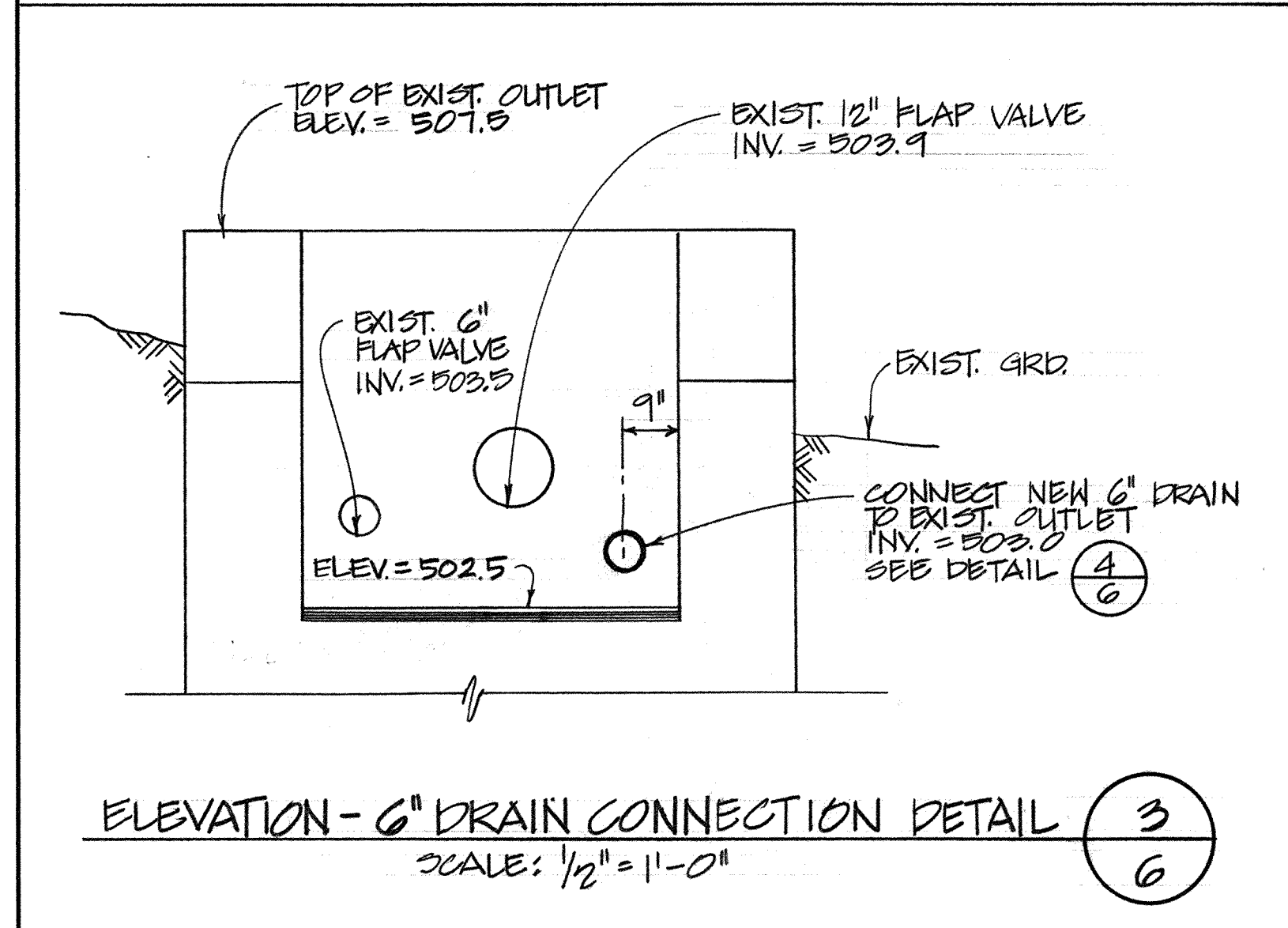
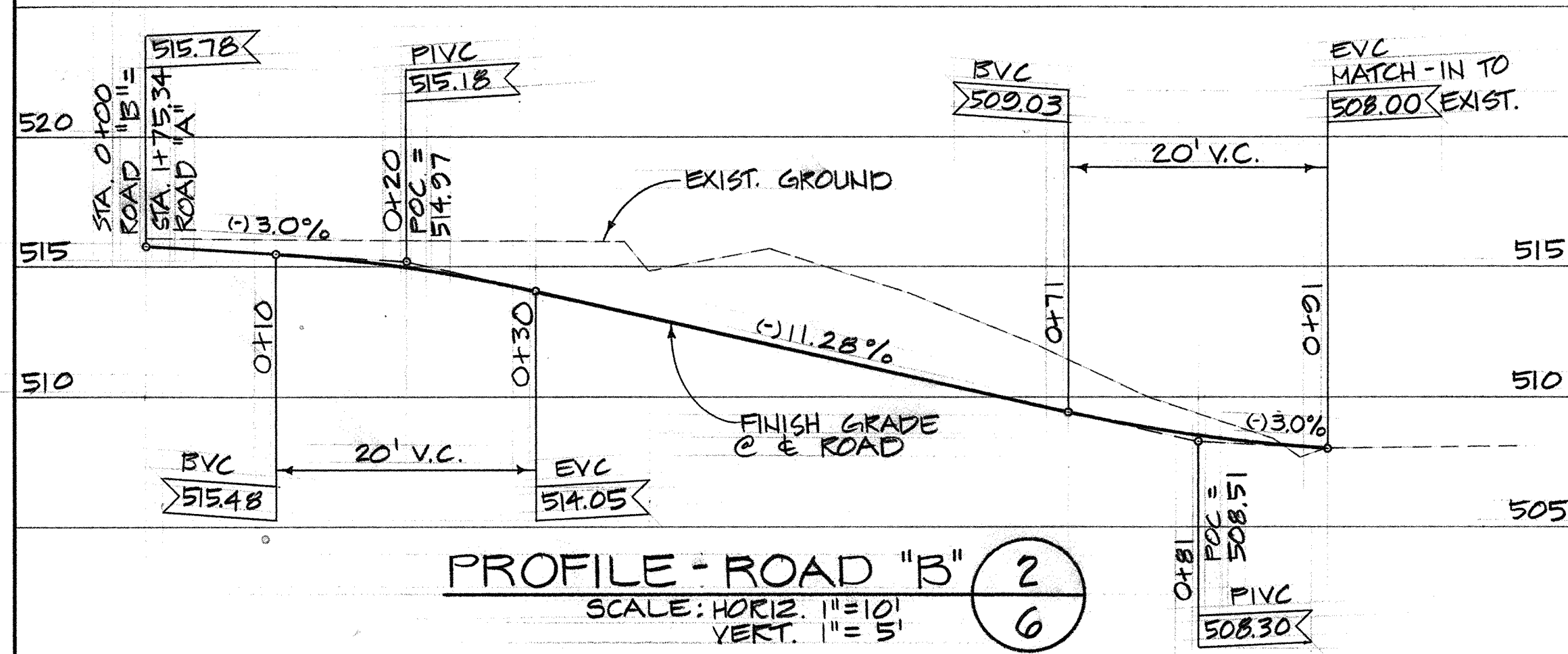

REVISION DATE	DESCRIPTION	MADE BY	APPROVED

AKINAKA & ASSOCIATES, LTD.
 CONSULTING ENGINEERS
 JOB NO. 85-5
 PUMP, CONTROLS, PUMPHOUSE AND
 CONNECTING PIPELINE FOR MAKALEHA
 WELL NO. 0623-04
 KAPAA WATER SYSTEM
 KAPAA, KAUAI, HAWAII

**MISCELLANEOUS
 PROFILES AND DETAILS**

APPROVED: *Raymond D. Yama* 7-1-87
 MANAGER / CHIEF ENGINEER, DEPT. OF WATER SUPPLY

RONALD T. YAMA
 REGISTERED
 PROFESSIONAL
 ENGINEER
 No. 2234-C
 HAWAII, U.S.A.

THIS WORK WAS PREPARED BY
 ME OR UNDER MY SUPERVISION.
Raymond D. Yama

MAKALEHA WELL PUMP PIPING MATERIAL LIST

ITEM NO.	QUANTITY	DESCRIPTION
1	3	8" ROCKWELL 914 INCREASING FL. COUPLING ADAPTER (6"x8")
2	1	8" D.I. PIPE, F.E.-P.E., 2'-0" LONG
3	1	8" x 4" TEE, F.E.
4	2	8" x 6" 4" 90° BEND, F.E., REDUCING BEND, F.E. Δ
5	1	6" 4" CLAYTON COMBINATION PRESSURE RELIEF, AIR RELEASE AND VACUUM BREAKER VALVE, F.E., CLAYTON 50-05
6	2	8" x 4" REDUCER, F.E.
7	1	6" 4" CLAYTON 60-31 PUMP CONTROL VALVE, F.E.
8	1	8" D.I. PIPE F.E. 6'-0" LONG
9	1	FLOTECH, VANE TYPE FLOW SWITCH
10	1	1/2" TAP FOR SAMPLING CONNECTION, SEE DETAIL 4/7
11	1	8" TURBINE METER, F.E., WATER SPECIALTIES MODEL ML-03 (REMOTE METER REGISTER IN PUMP BLDG.) OR APPROVED EQUAL
12	1	8" D.I. PIPE, F.E.-P.E. 3'-0" LONG
13	1	8" WYE F.E. W/BLIND FLANGE W/3" TAP & PLUG
14	1	8" BLIND FLANGE
15	1	8" GATE VALVE, 150# F.E. O.S. & Y.
16	1	8" D.I. PIPE, F.E. 2'-0" LONG
17	1	2" COMBINATION ARV, APCO NO. 145 C OR APPROVED EQUAL WITH 2" RISER PIPE AND 2" TAP SERVICE SADDLE WITH SINGLE STRAP IRON, ROCKWELL #31/OR APPROVED EQUAL
18	1	8" 45° BEND, F.E.
19	1	8" D.I. PIPE, P.E., VERIFY LENGTH IN FIELD
20	1	8" 45° BEND, M.J.
21	1	12" x 8" REDUCER, M.J. L.E.B. W/CONC. REACTION BLOCK
22	1	8" 6" D.I. PIPE, F.E., 6'-0" LONG Δ
23	1	8" 6" x 4" 90° REDUCING BEND, F.E.
24	1	8" 4" SILENT CHECK VALVE, CPV OR APPROVED EQUAL, F.E.

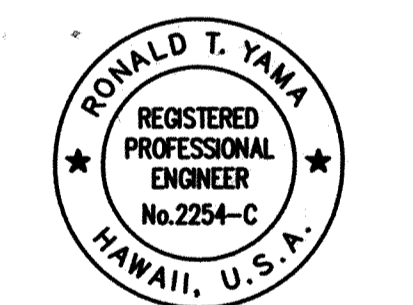
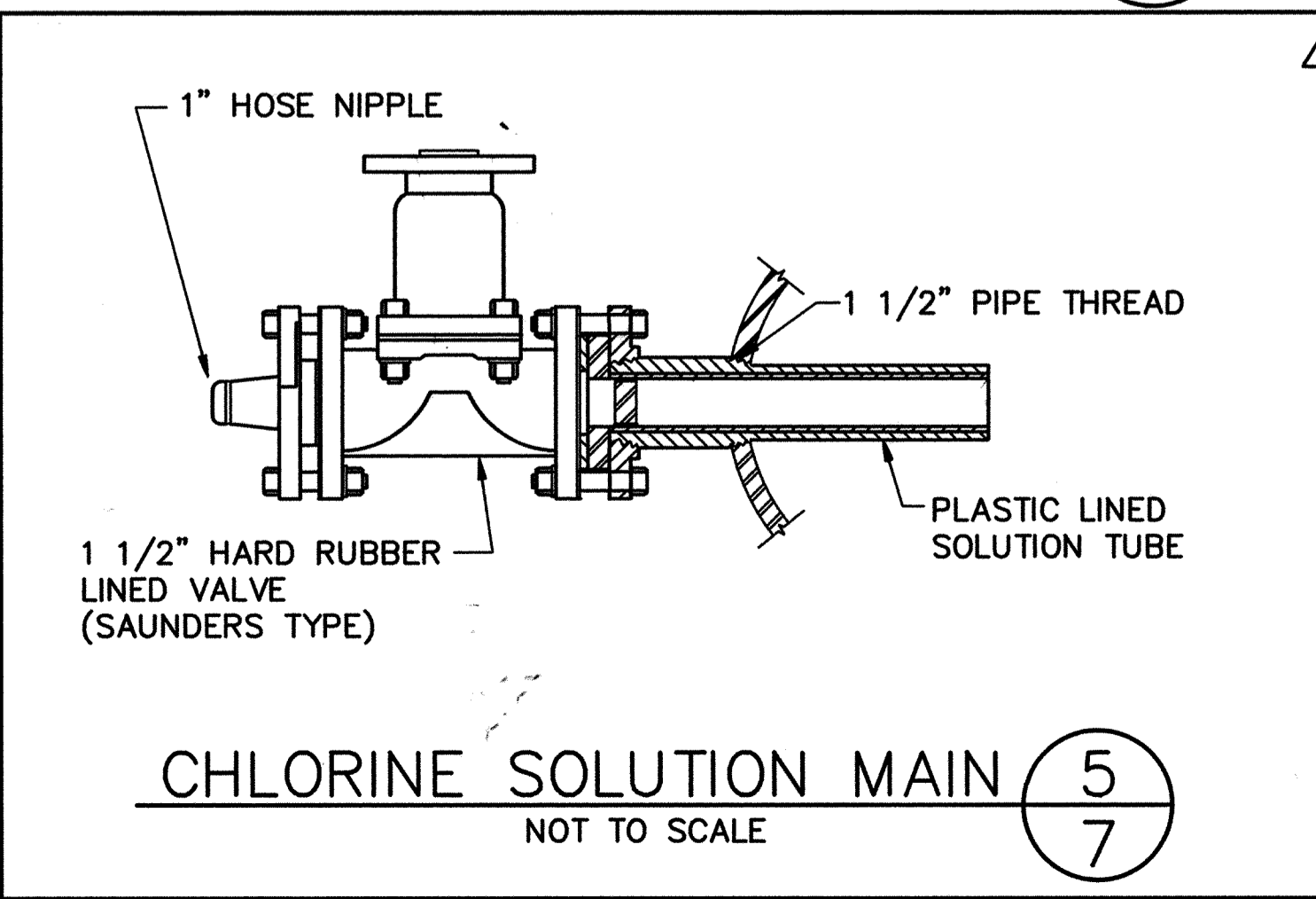
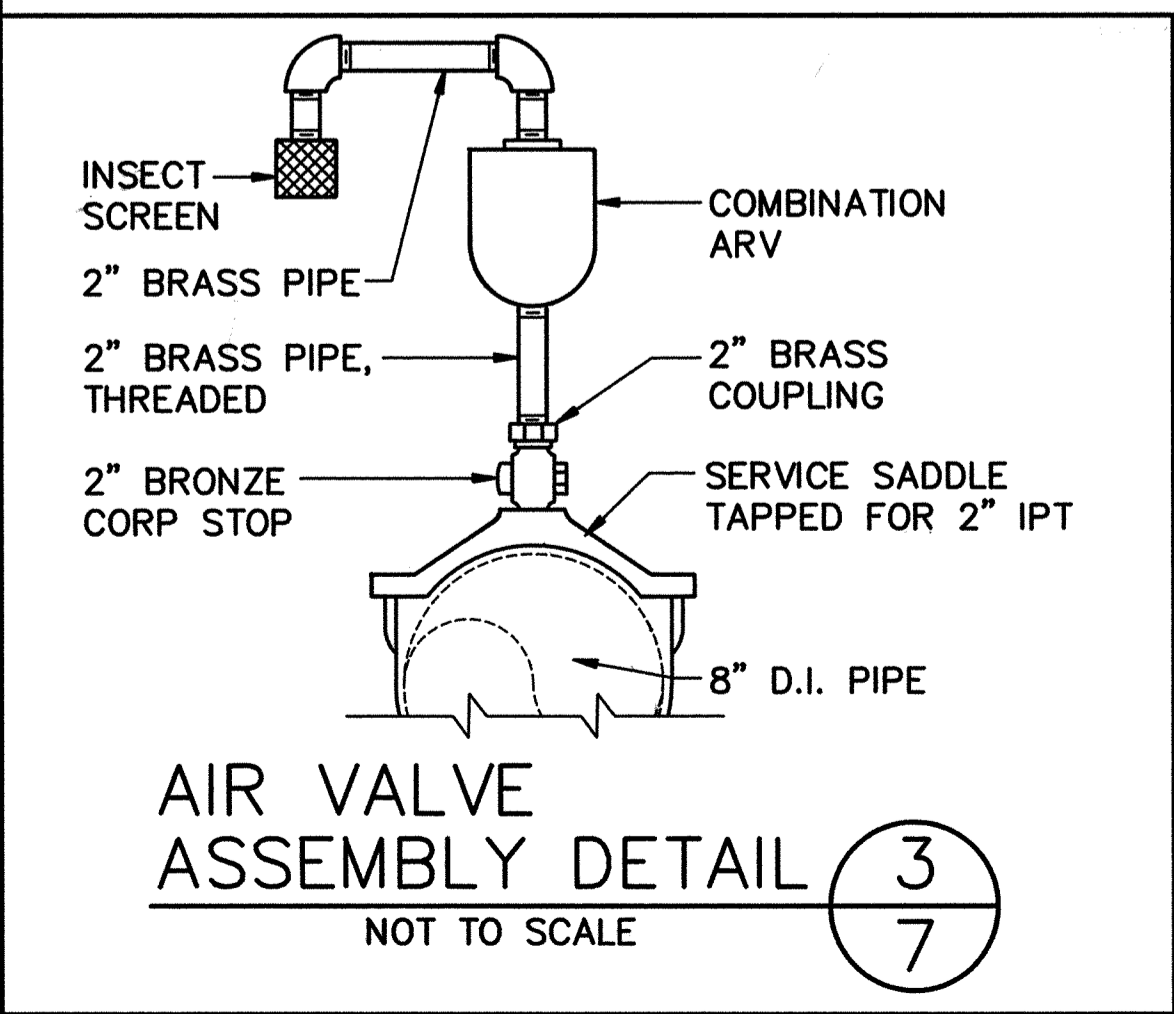
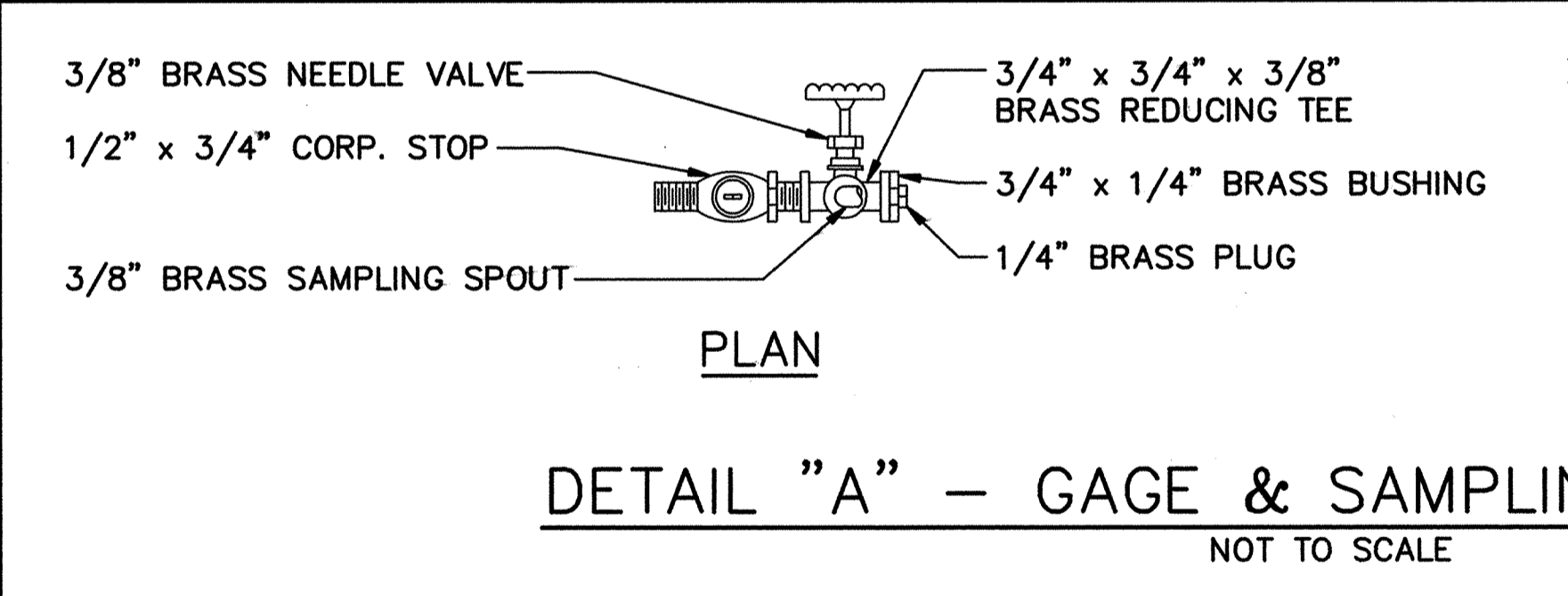
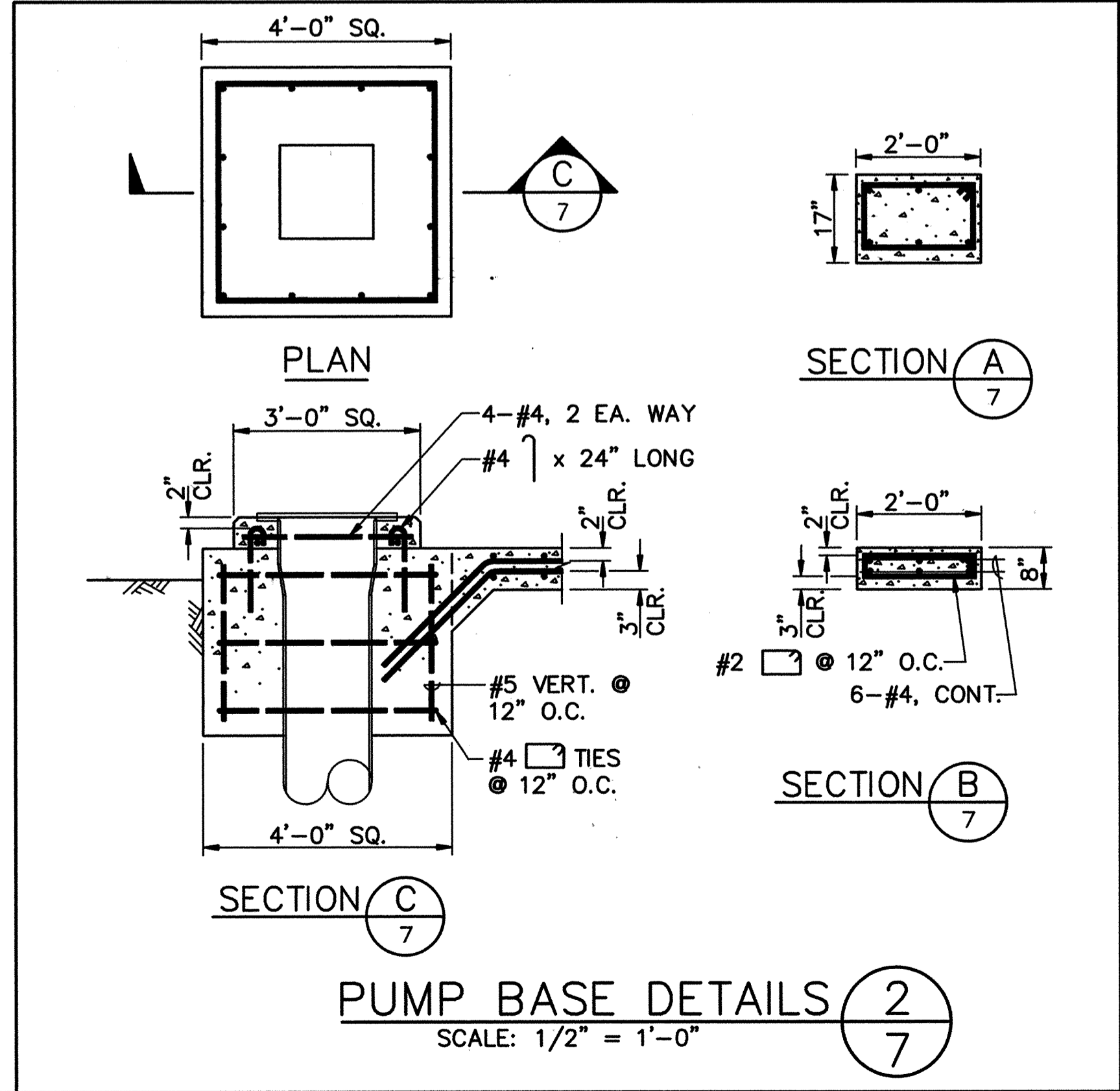
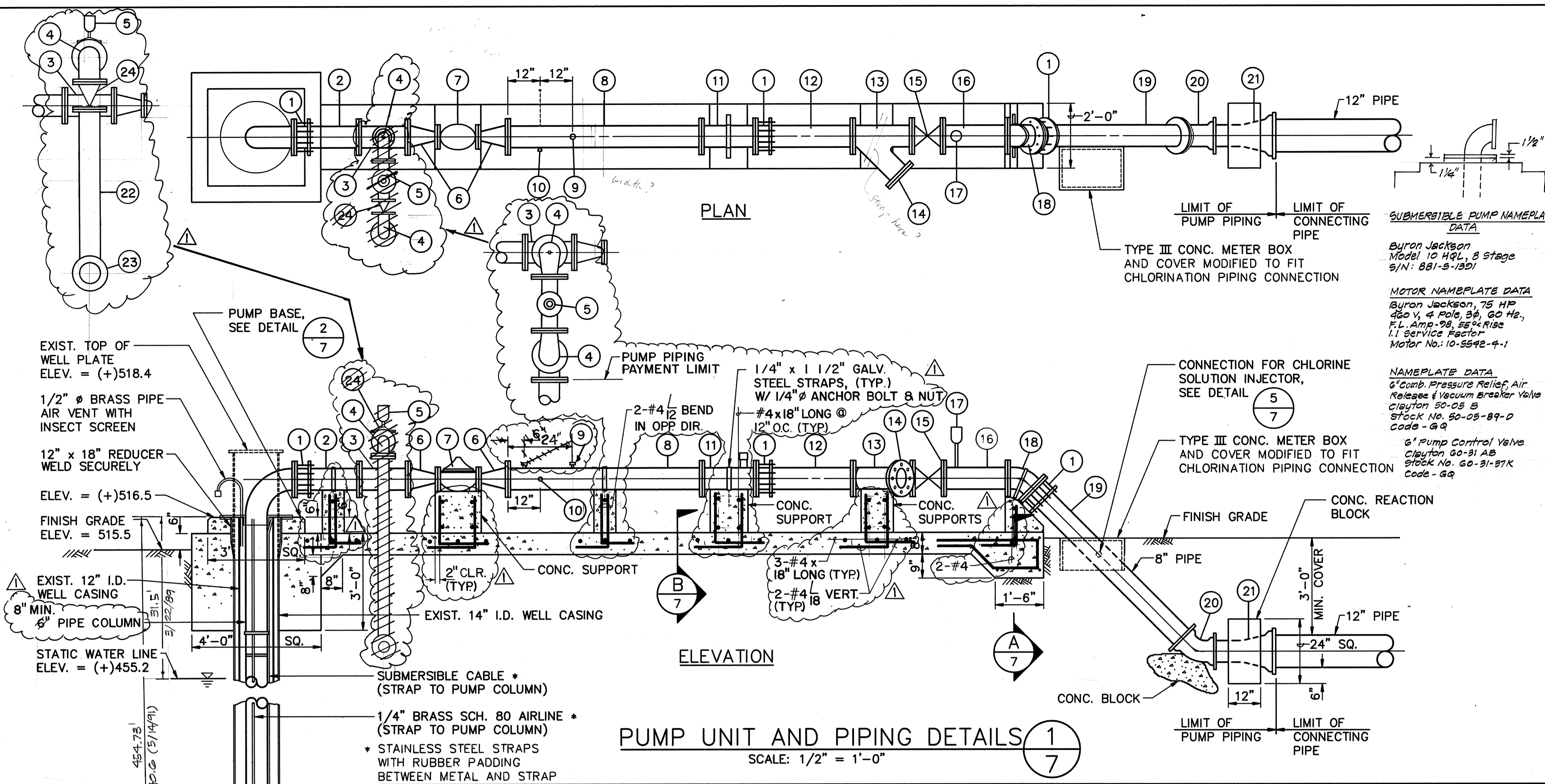

THIS WORK WAS PREPARED BY ME OR UNDER MY SUPERVISION
 Ronald T. Yama

11/23/87	REVISED PUMP UNIT AND PIPING DETAILS	A&A	R. Yama
REVISION DATE	DESCRIPTION	MADE BY	APPROVED
AKINAKA & ASSOCIATES, LTD. CONSULTING ENGINEERS			
JOB NO. 85-5 PUMP, CONTROLS, PUMPHOUSE AND CONNECTING PIPELINE FOR MAKALEHA WELL NO. 0623-04 KAPAA WATER SYSTEM KAPAA, KAUAI, HAWAII			
WELL PUMP PIPING DETAILS			
APPROVED: <i>Ronald T. Yama</i>		7-1-87 DATE	
MANAGER & CHIEF ENGINEER, DEPT. OF WATER SUPPLY			

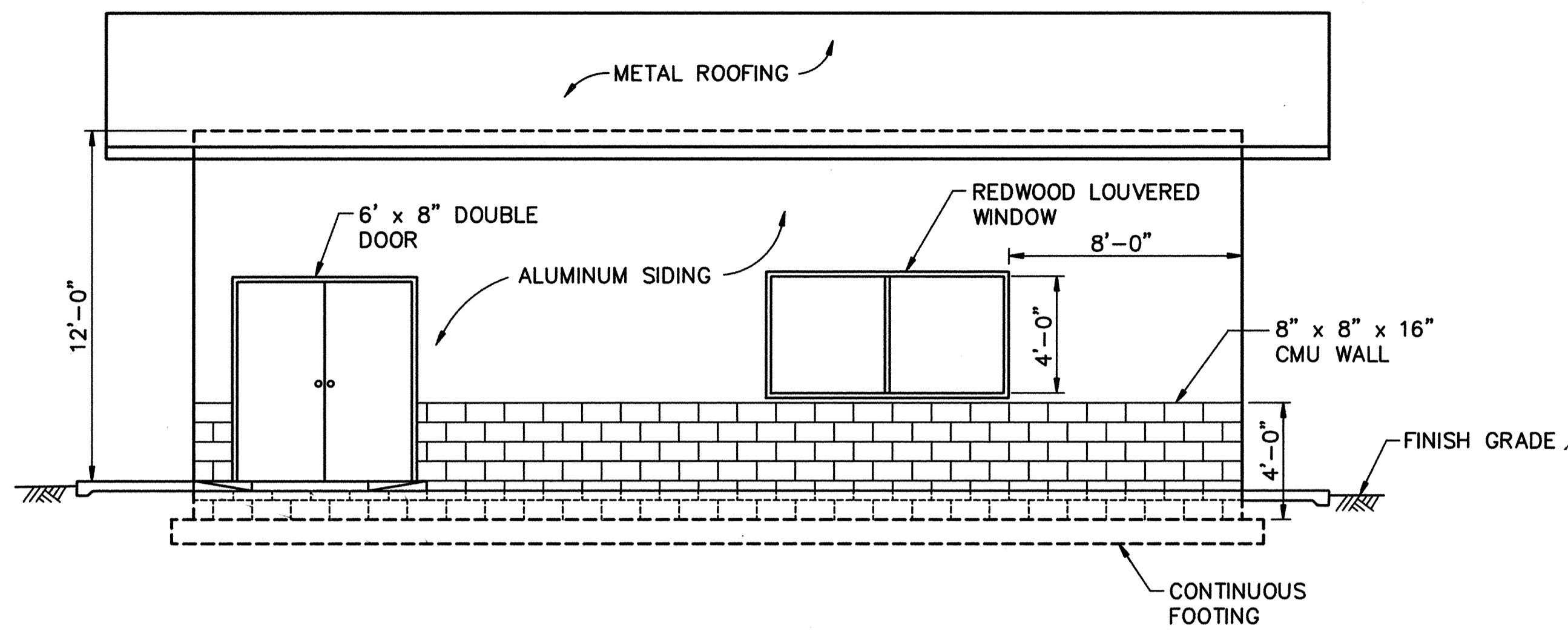

NORTH ELEVATION
SCALE: 1/4" = 1'-0"

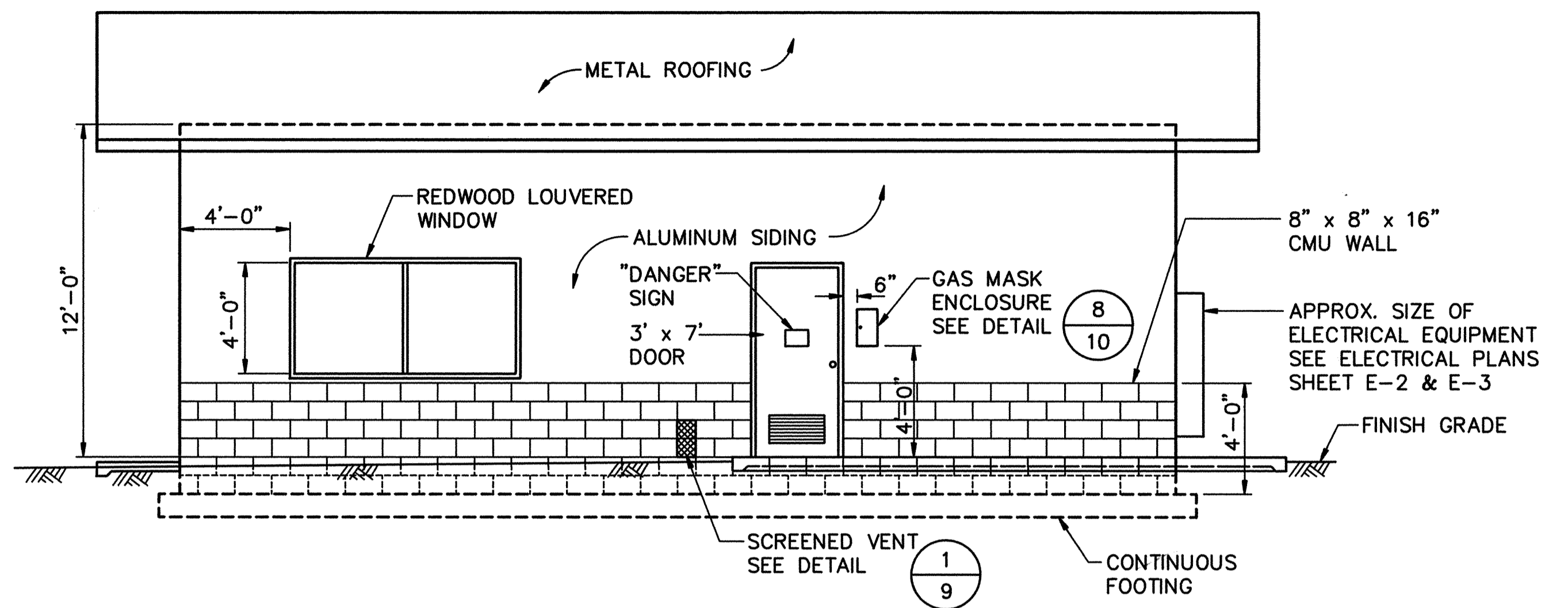

SOUTH ELEVATION
SCALE: 1/4" = 1'-0"

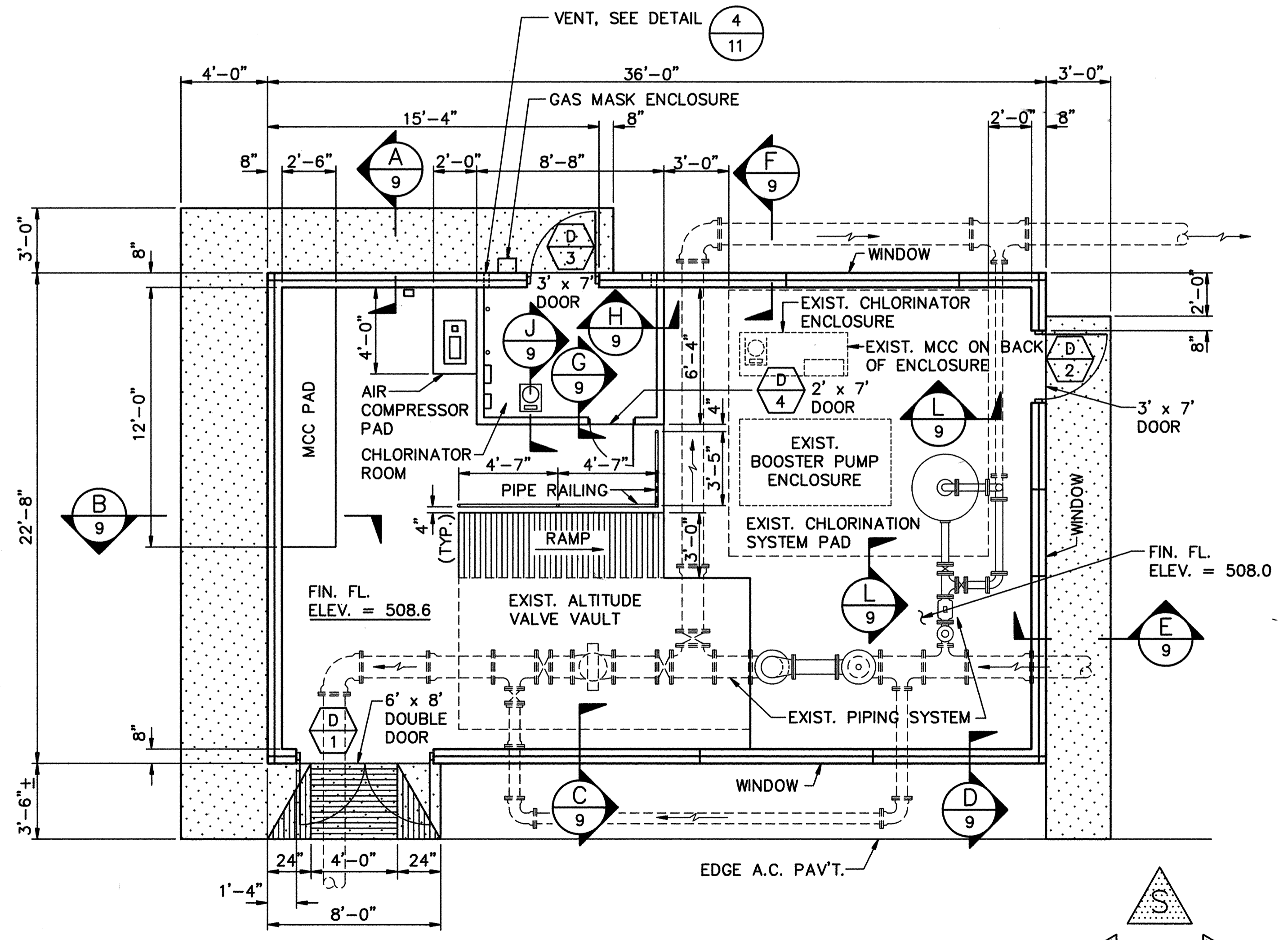

CONTROL BUILDING FLOOR PLAN
SCALE: 1/4" = 1'-0"

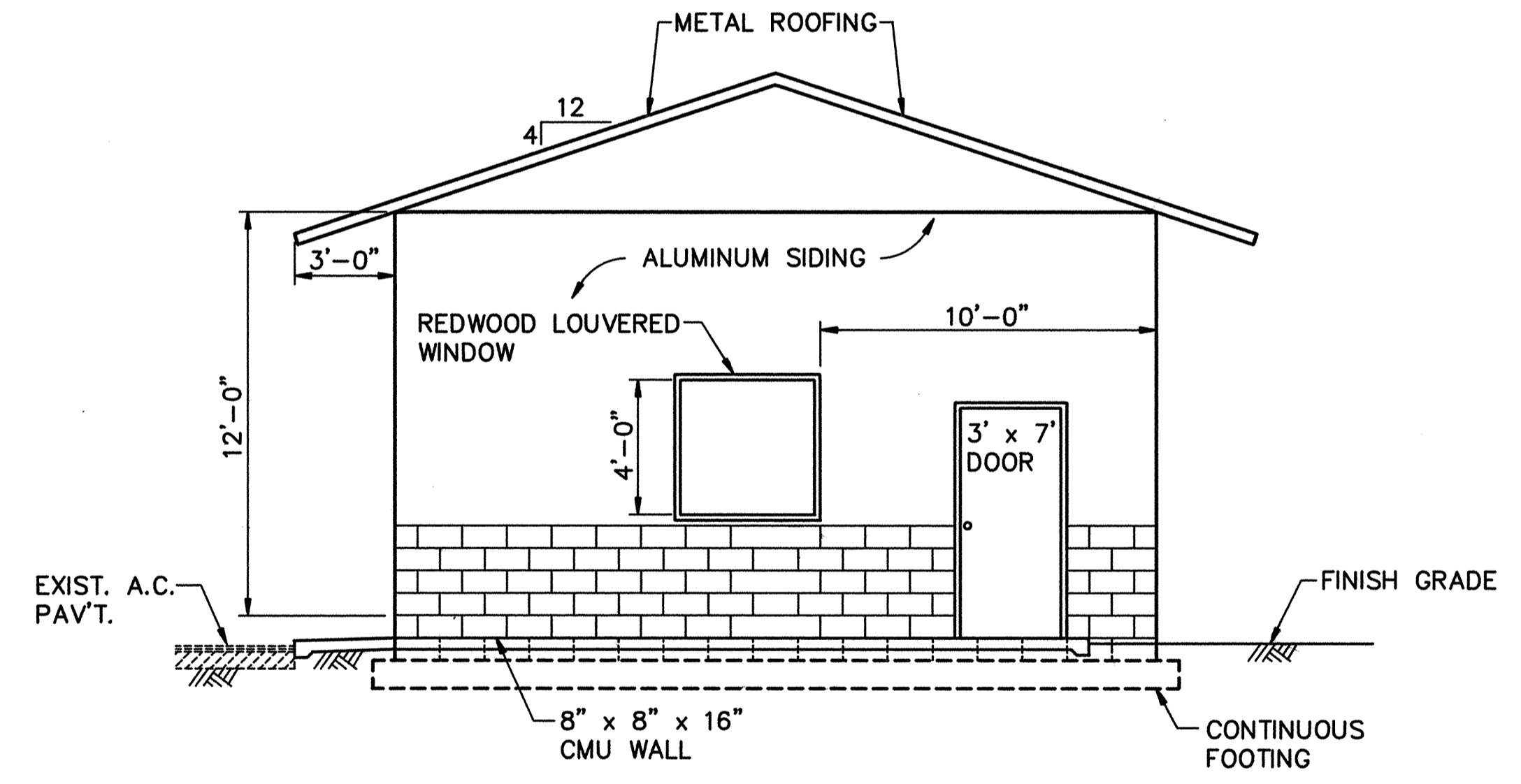
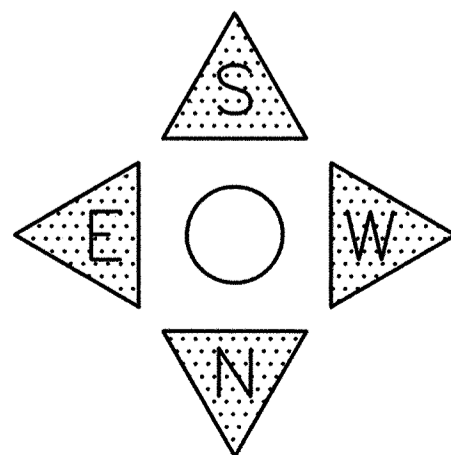

WEST ELEVATION
SCALE: 1/4" = 1'-0"



THIS WORK WAS PREPARED BY ME OR UNDER MY SUPERVISION
Ronald T. Yama

REVISION DATE	DESCRIPTION	MADE BY	APPROVED
AKINAKA & ASSOCIATES, LTD. CONSULTING ENGINEERS JOB NO. 85-5 PUMP, CONTROLS, PUMPHOUSE AND CONNECTING PIPELINE FOR MAKALEHA WELL NO. 0623-04 KAPAA WATER SYSTEM KAPAA, KAUAI, HAWAII			
CONTROL BUILDING DETAILS			
APPROVED: <i>Raymond L. Peltz</i> MANAGER & CHIEF ENGINEER, DEPT. OF WATER SUPPLY			7-1-87 DATE

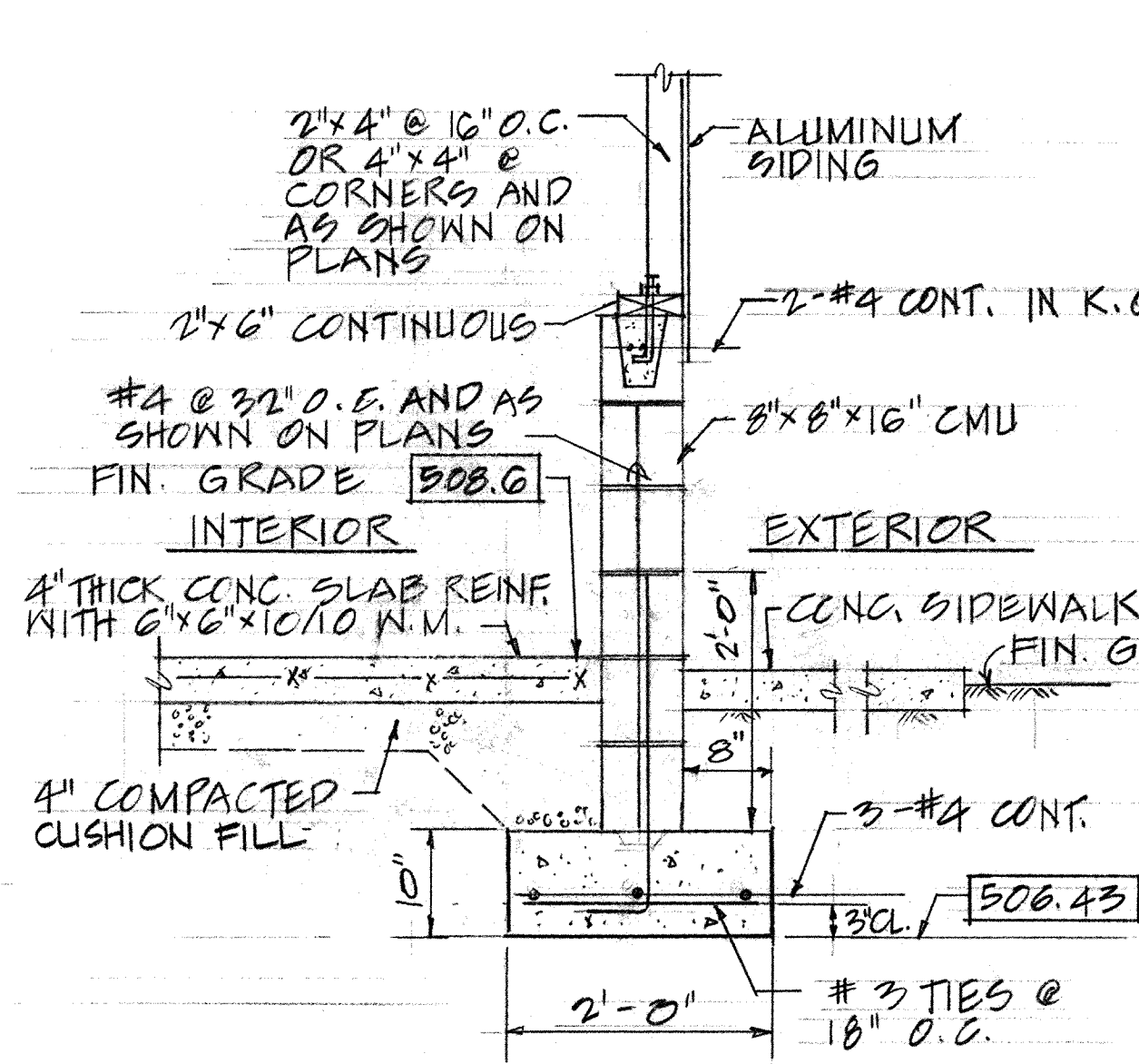

SECTION A
SCALE: 3/4" = 1'-0"

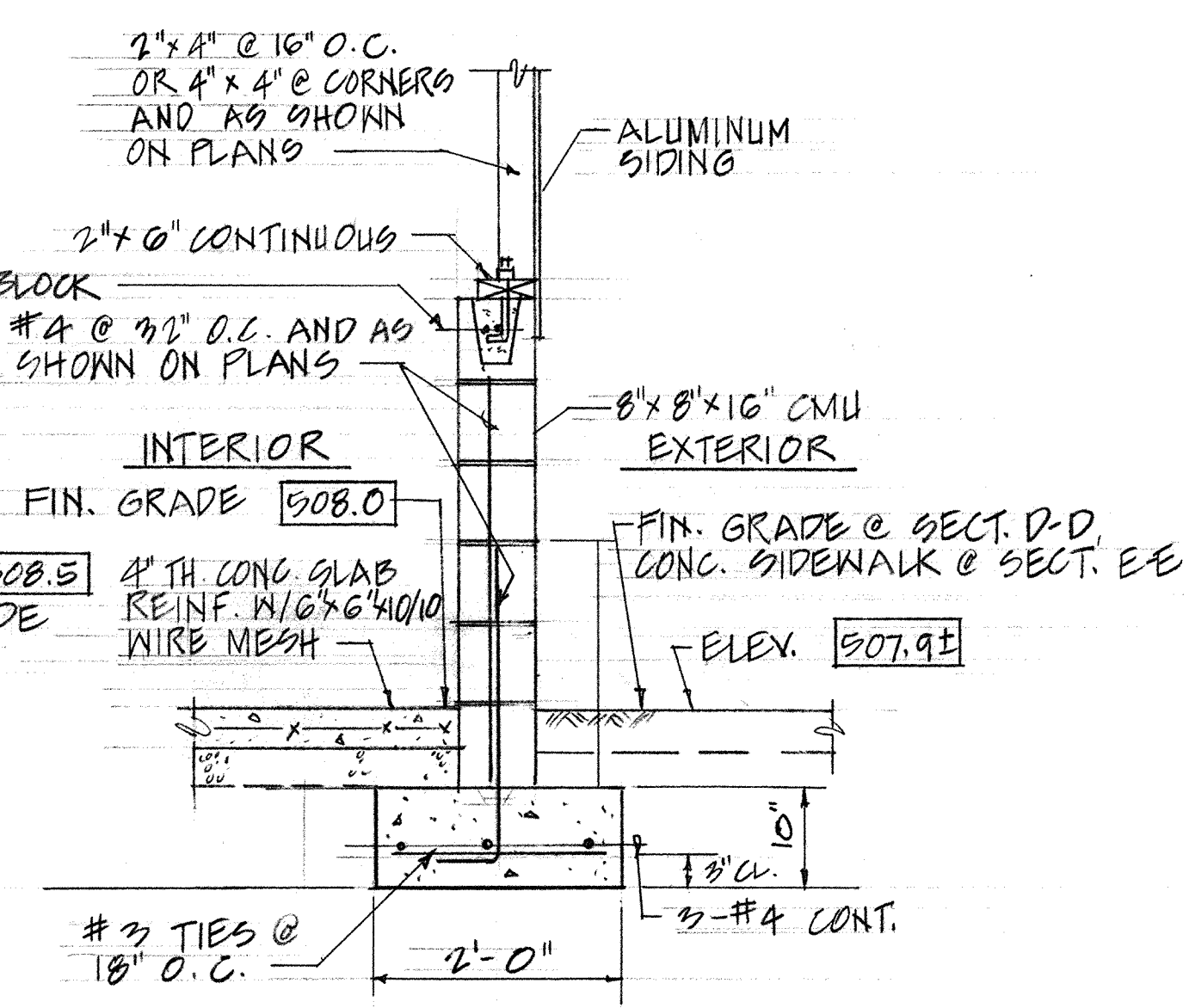

SECTION D E
SCALE: 3/4" = 1'-0"

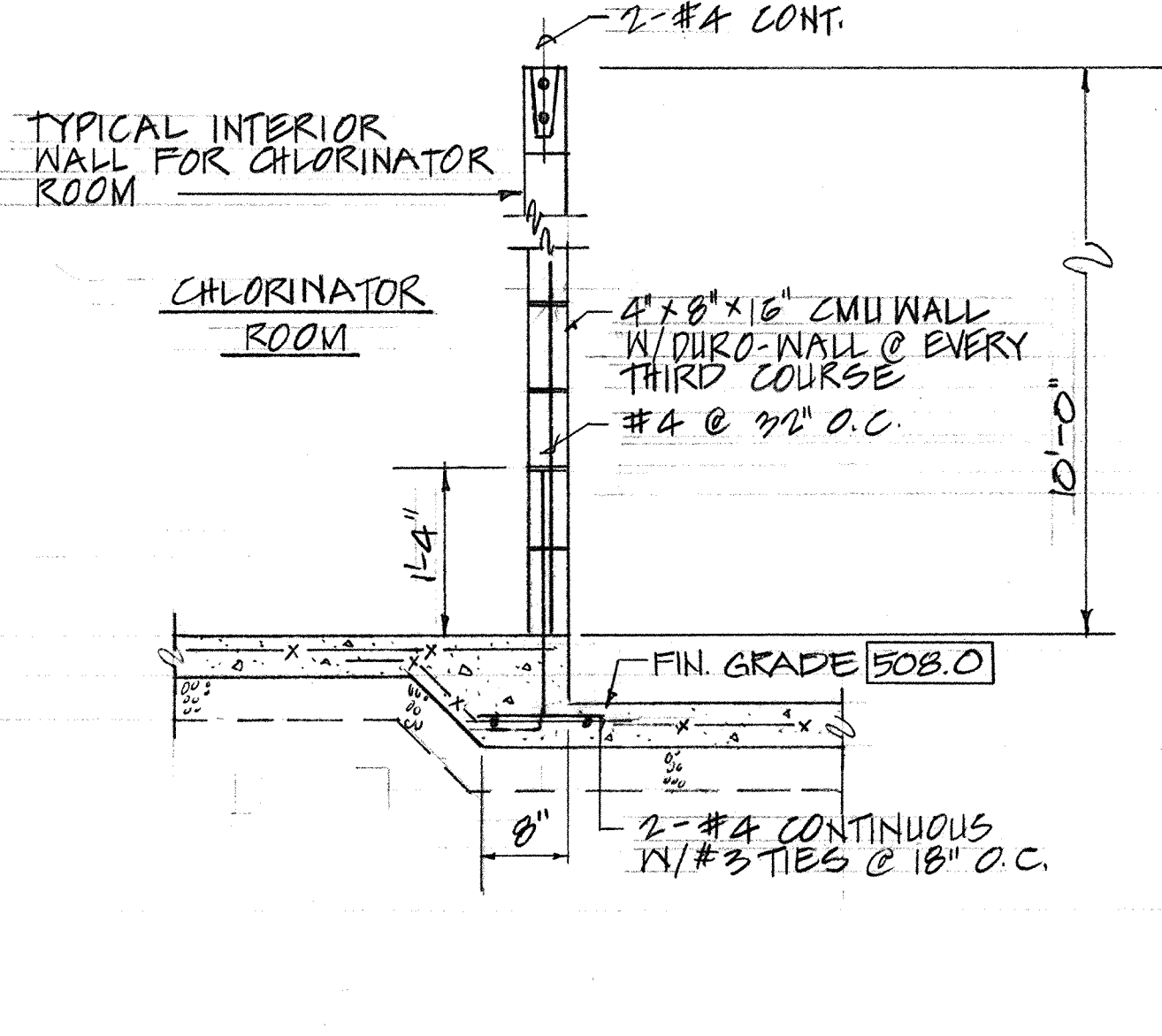

SECTION H
SCALE: 3/4" = 1'-0"

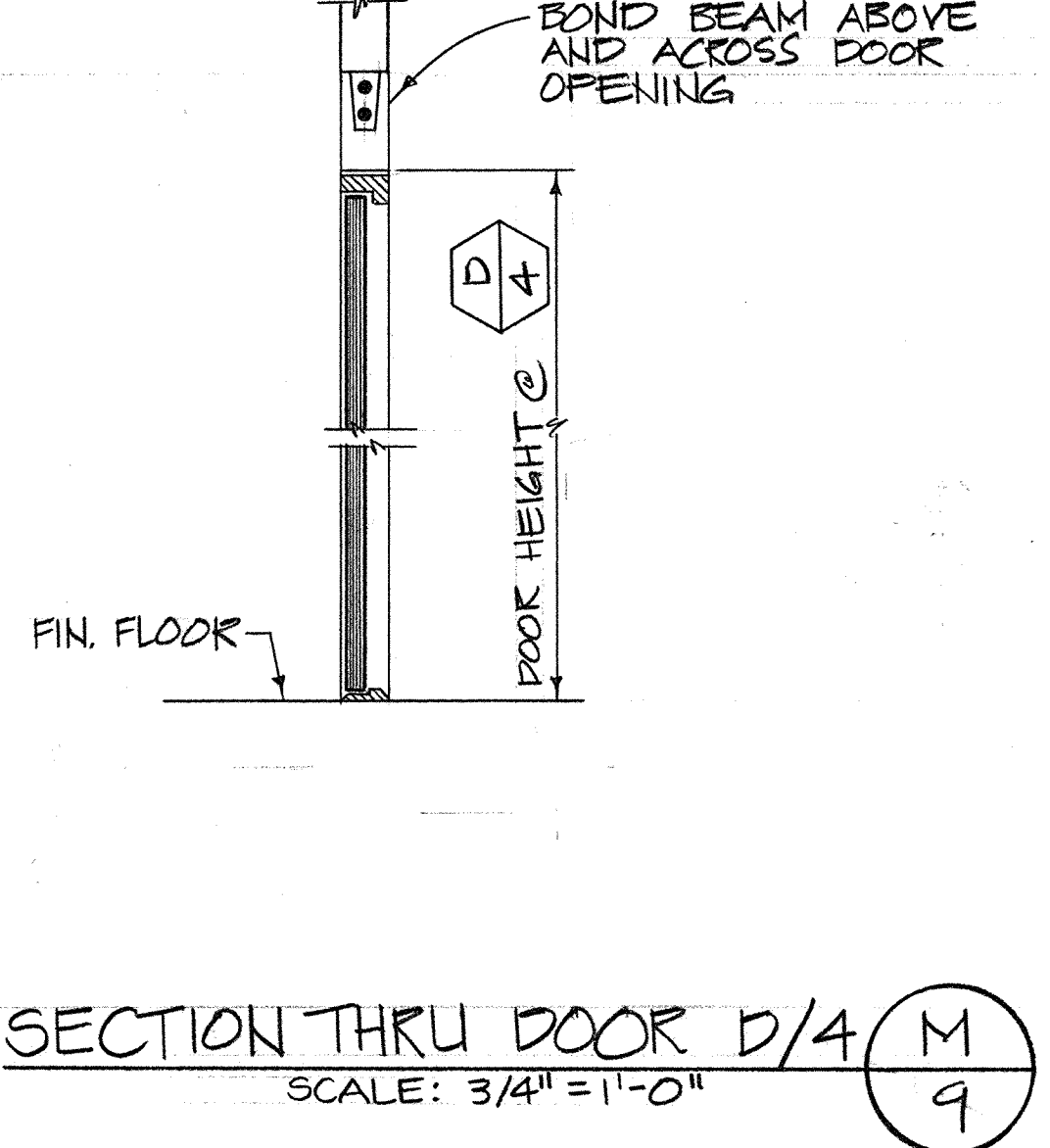

SECTION THRU DOOR D/4 M
SCALE: 3/4" = 1'-0"

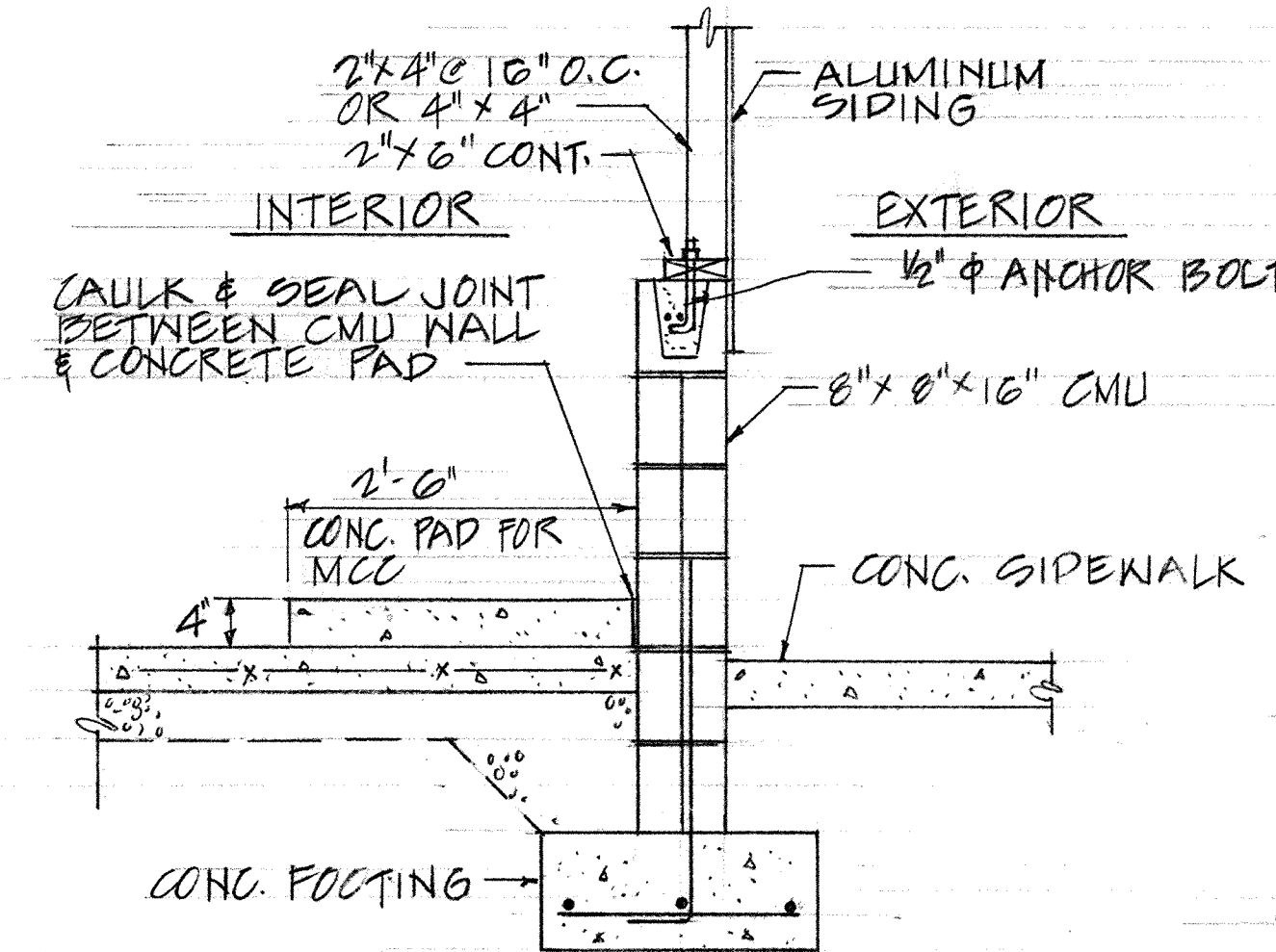

SECTION B
SCALE: 3/4" = 1'-0"

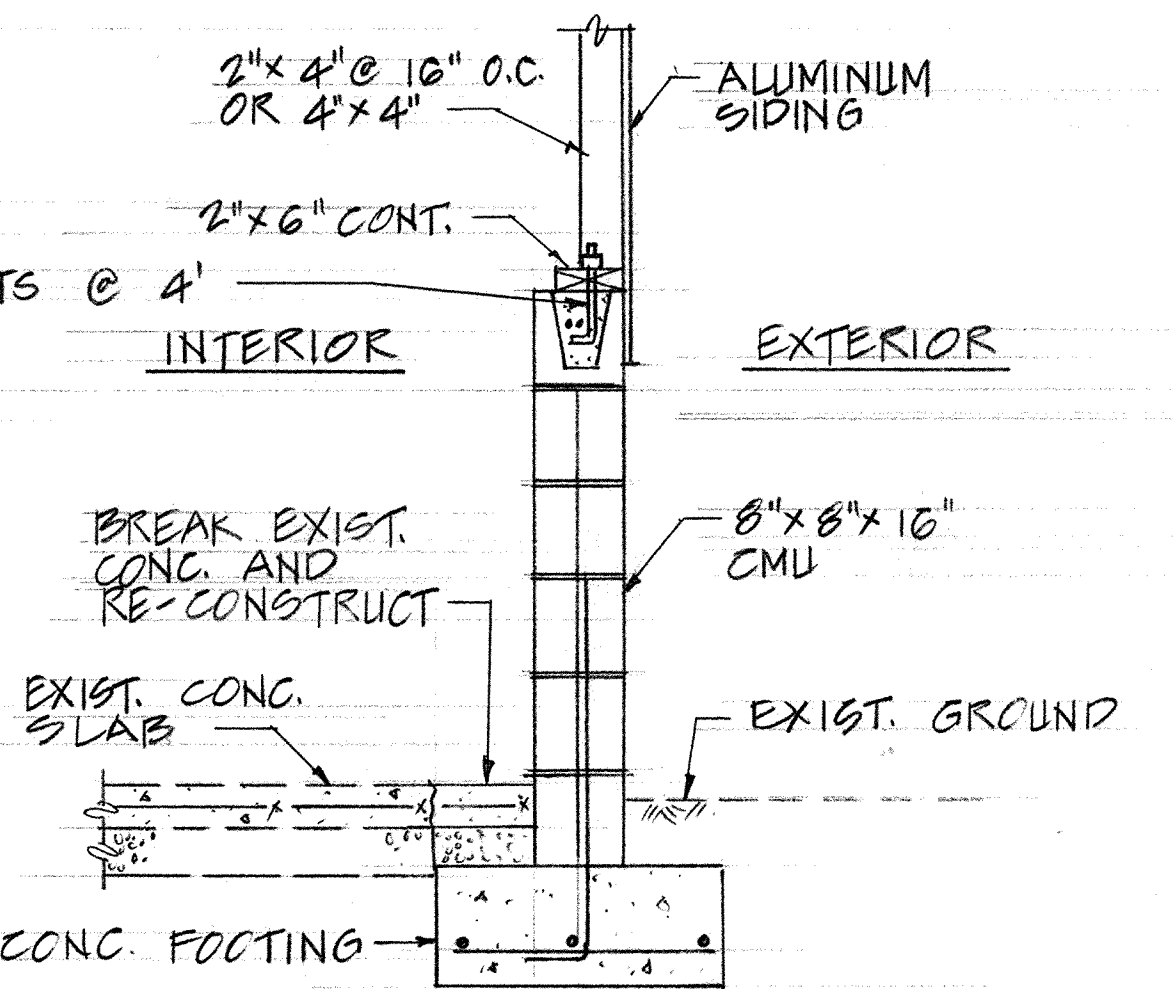

SECTION F
SCALE: 3/4" = 1'-0"

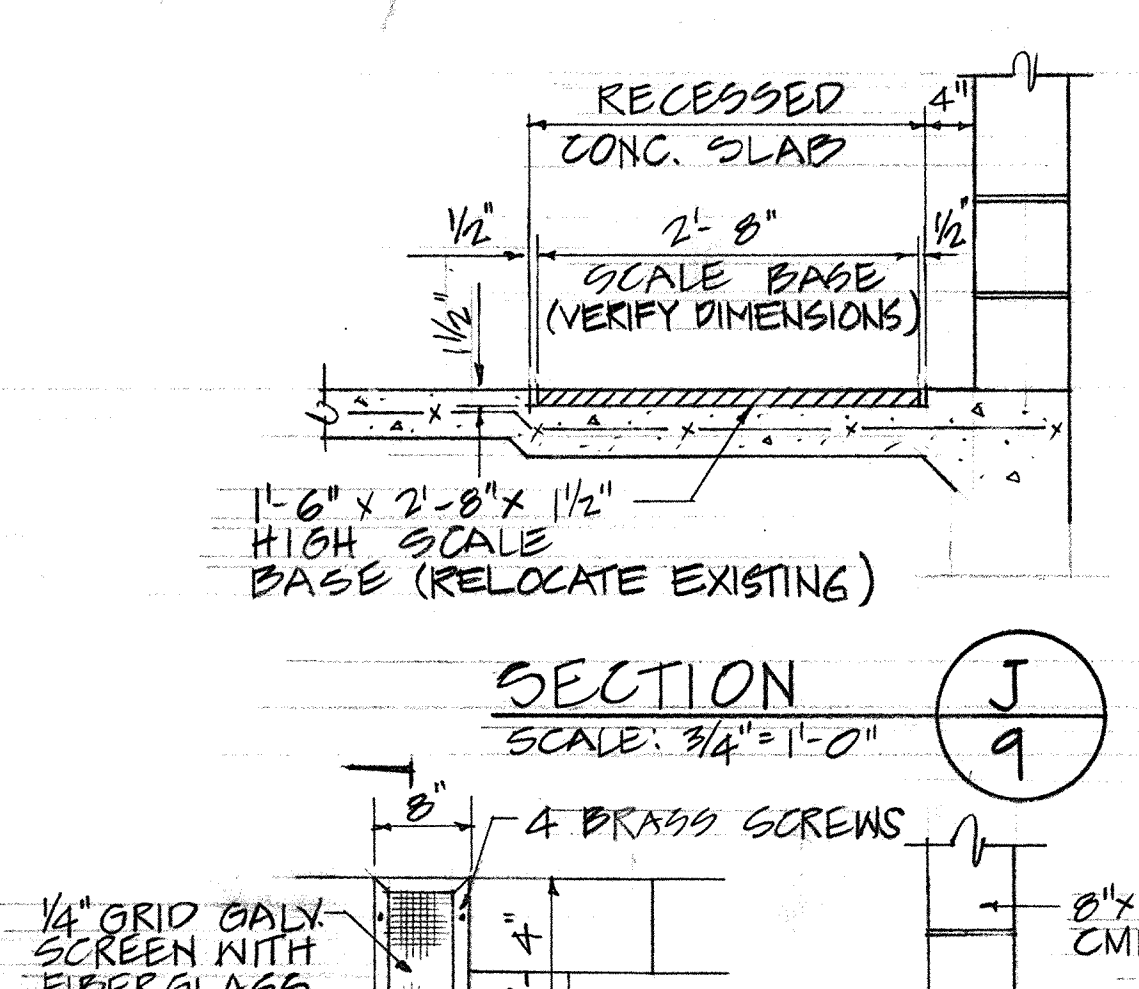

SECTION J
SCALE: 3/4" = 1'-0"

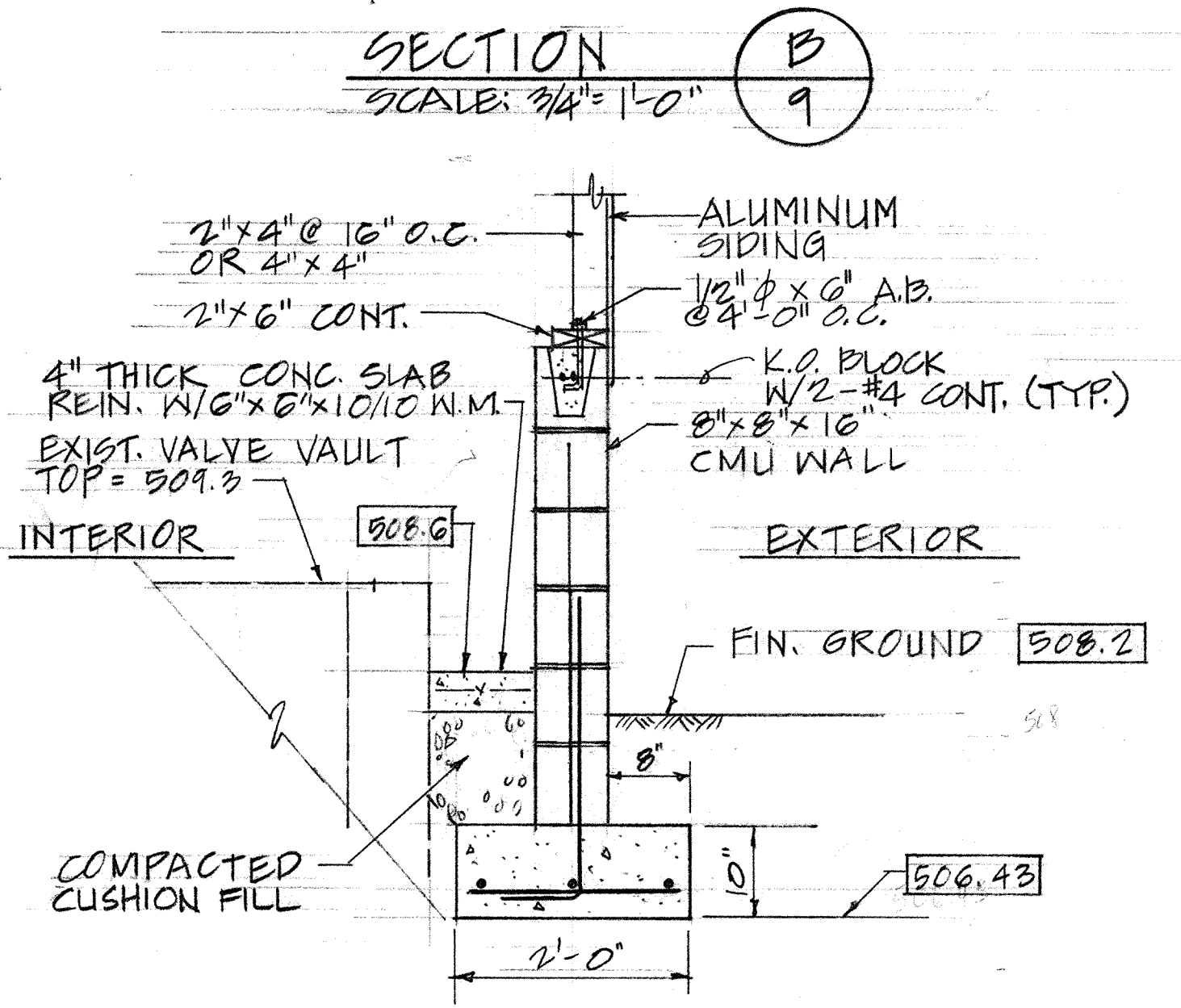

SECTION C
SCALE: 3/4" = 1'-0"

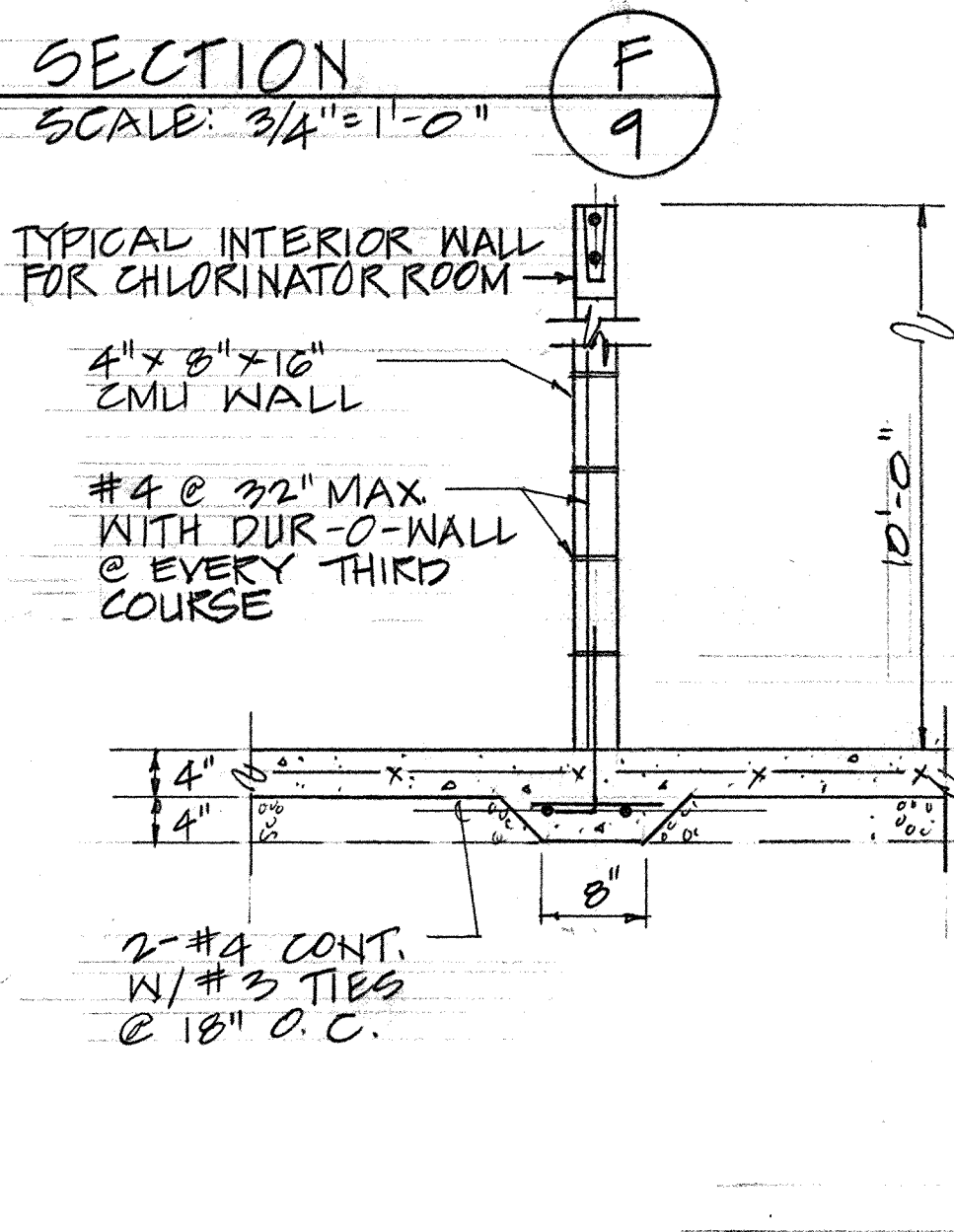

SECTION G
SCALE: 3/4" = 1'-0"

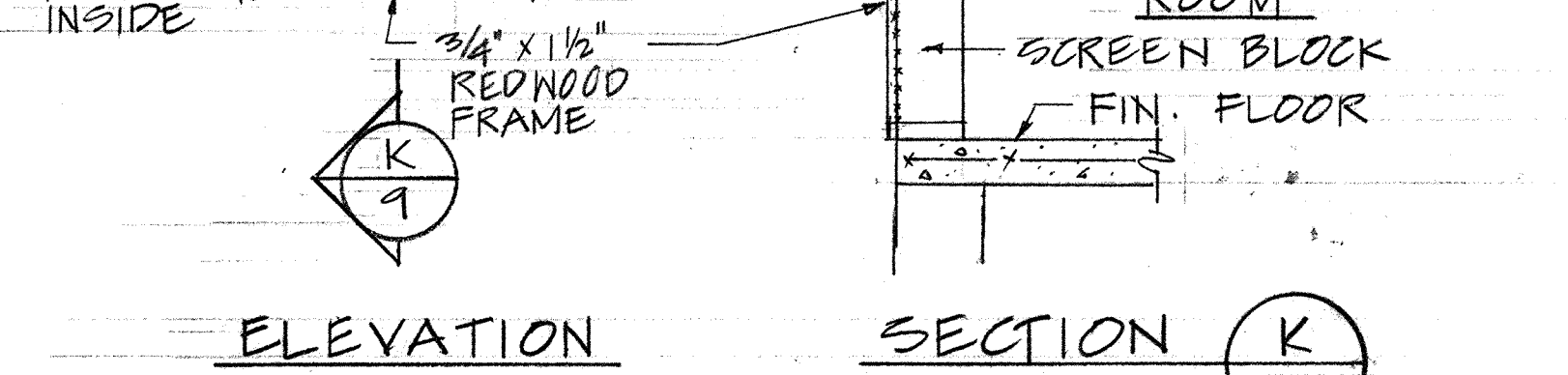

SECTION K
SCREENED VENT DETAIL
SCALE: 3/4" = 1'-0"

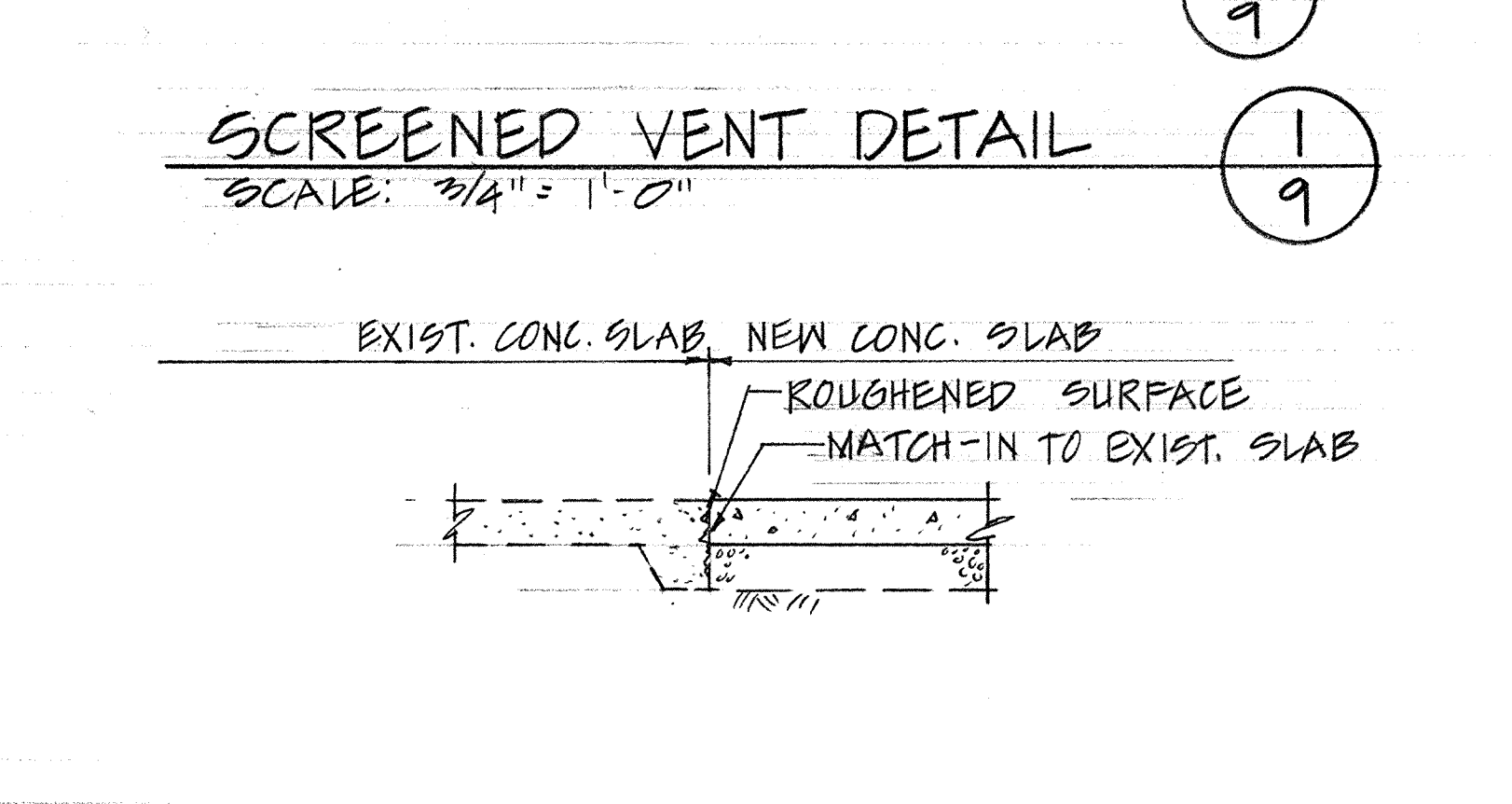

SECTION L
SCALE: 3/4" = 1'-0"

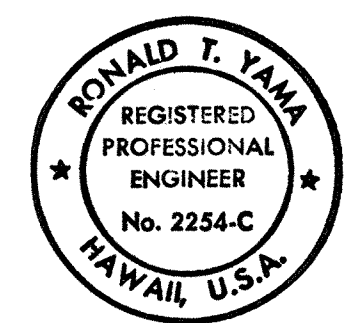

THIS WORK WAS PREPARED BY ME OR UNDER MY SUPERVISION.
Ronald T. Yama

REVISION DATE	DESCRIPTION	MADE BY	APPROVED

AKINAKA & ASSOCIATES, LTD.
CONSULTING ENGINEERS
JOB NO. 85-5
PUMP, CONTROLS, PUMPHOUSE AND CONNECTING PIPELINE FOR MAKALEHA WELL NO. 0623-04
KAPAA WATER SYSTEM
KAPAA, KAUAI, HAWAII

CONTROL BUILDING WALL SECTIONS

APPROVED: *Ronald T. Yama* 7-1-87
MANAGER & CHIEF ENGINEER, DEPT. OF WATER SUPPLY

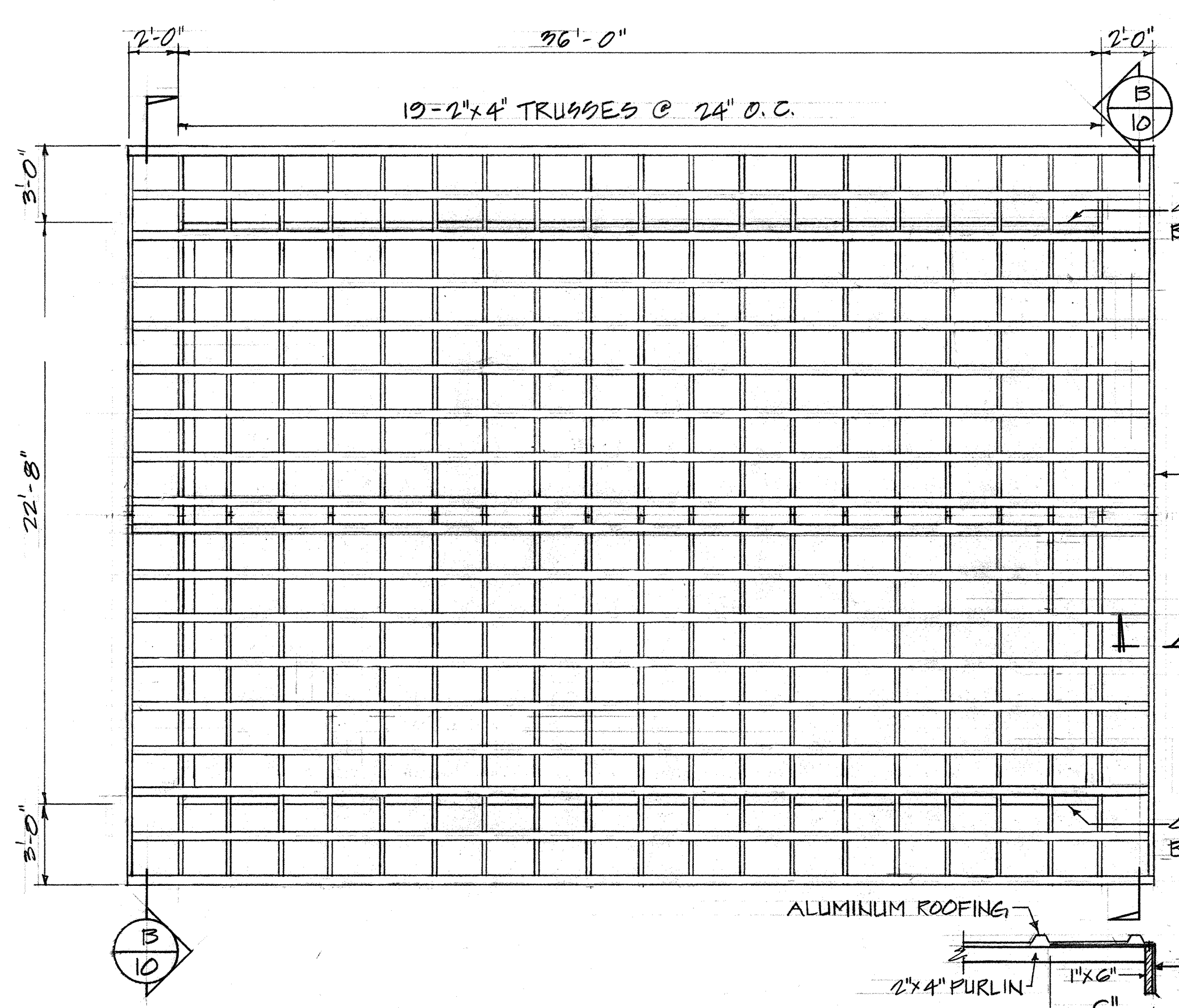

ROOF FRAMING PLAN
SCALE: 1/4" = 1'-0"

SECTION A
SCALE: 1" = 1'-0"

DOOR DETAIL
SCALE: 1 1/2" = 1'-0"

WINDOW DETAIL
SCALE: 1 1/2" = 1'-0"

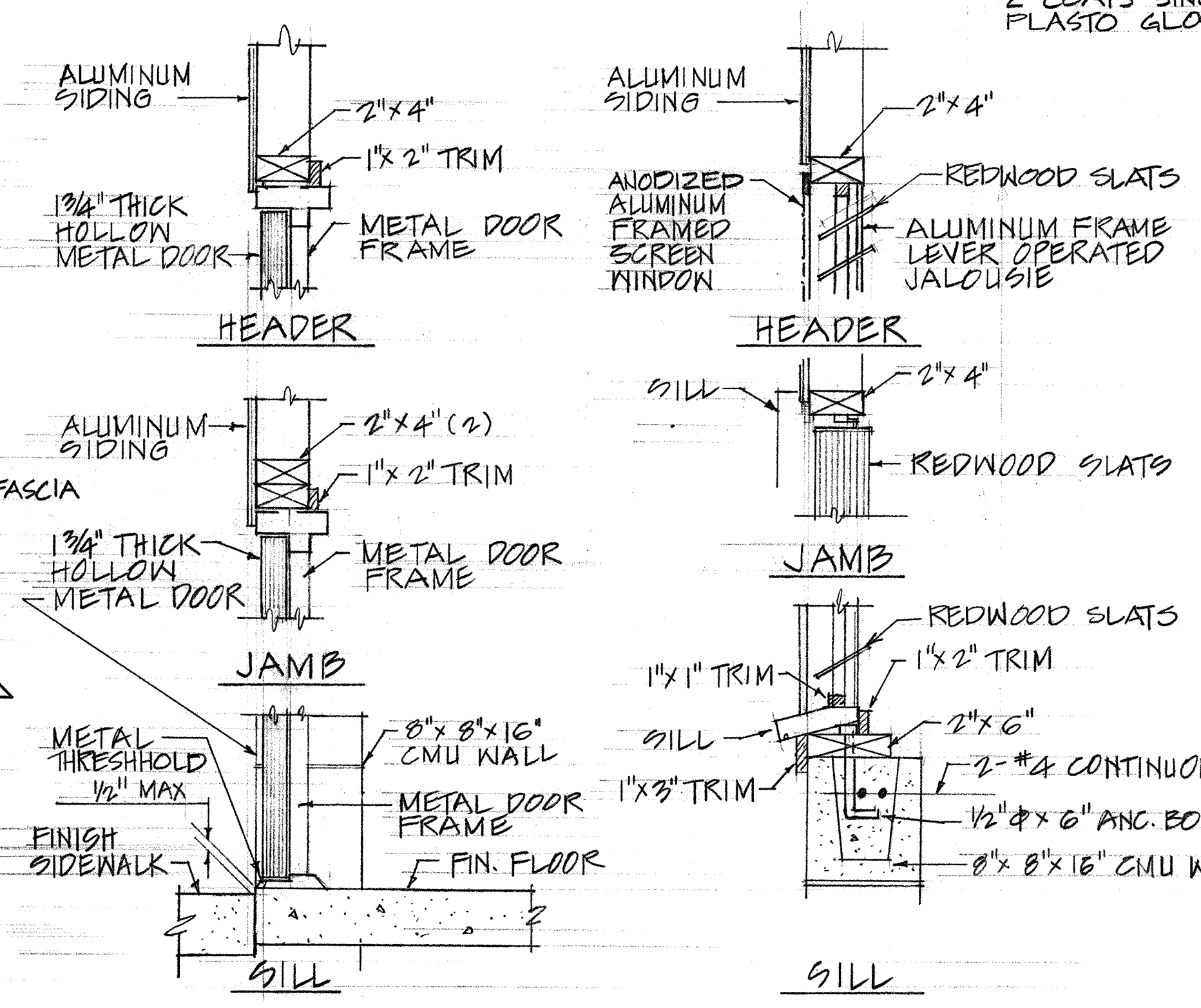

NOTE FOR REDWOOD SLATS:
1. SAND, SEAL & APPLY 2-COATS SINCLAIR 152 PLASTO GLOSS.

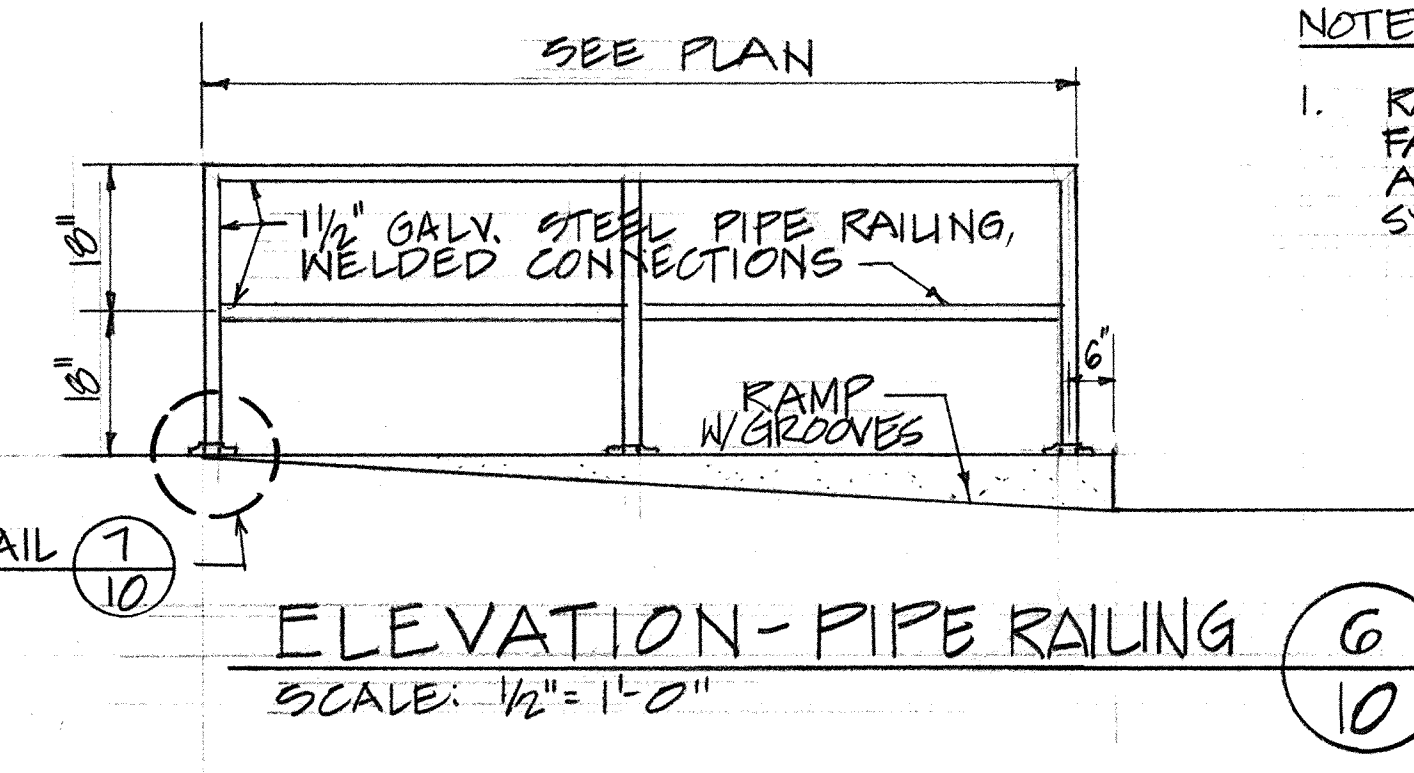

ELEVATION - PIPE RAILING
SCALE: 1/2" = 1'-0"

NOTE:
1. RAILING SHALL BE FABRICATED AND PAINTED AS PER THE WATER SYSTEM STANDARDS.

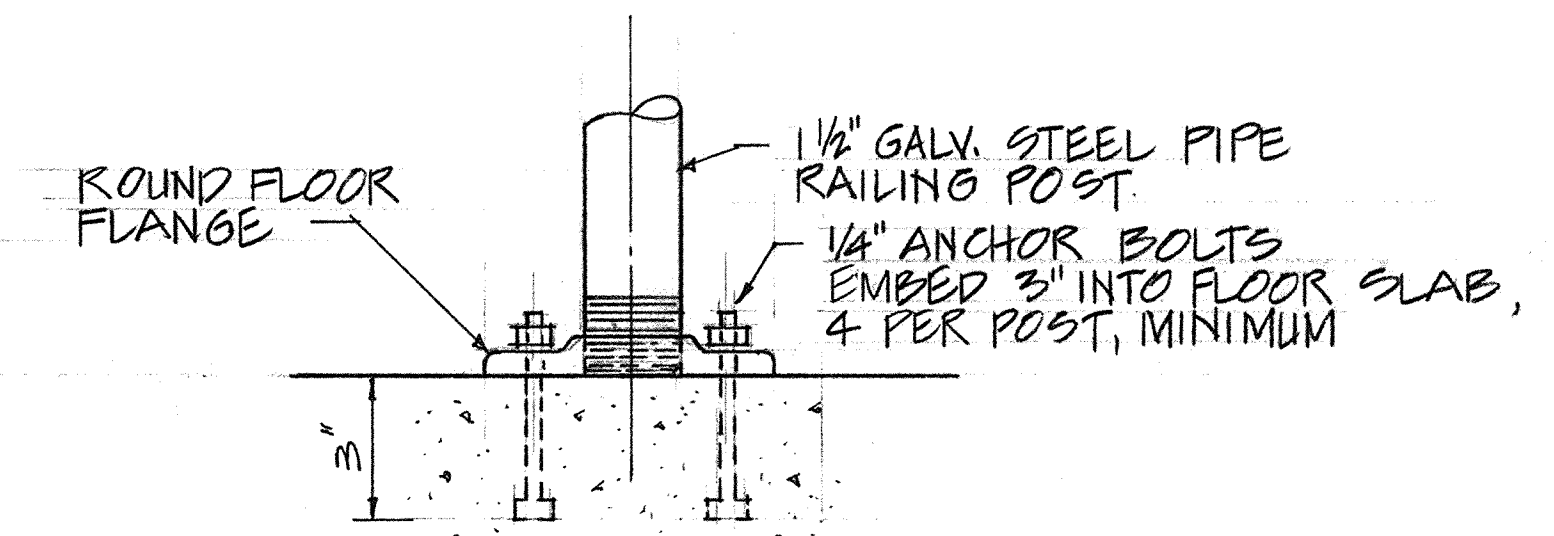

DETAIL - FLANGE BASE FOR G.I. RAILING POST
NOT TO SCALE

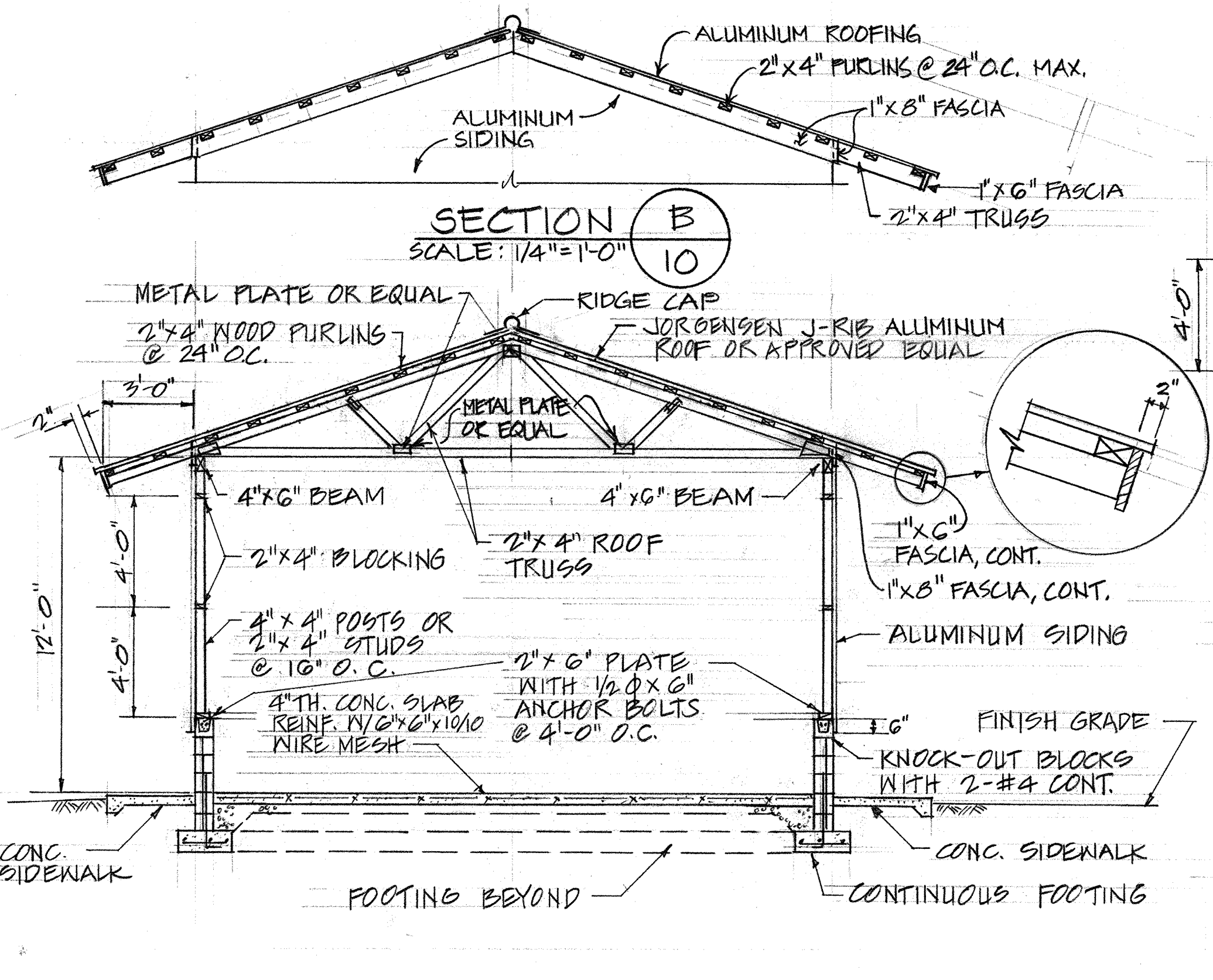

TYPICAL SECTION
SCALE: 1/4" = 1'-0"

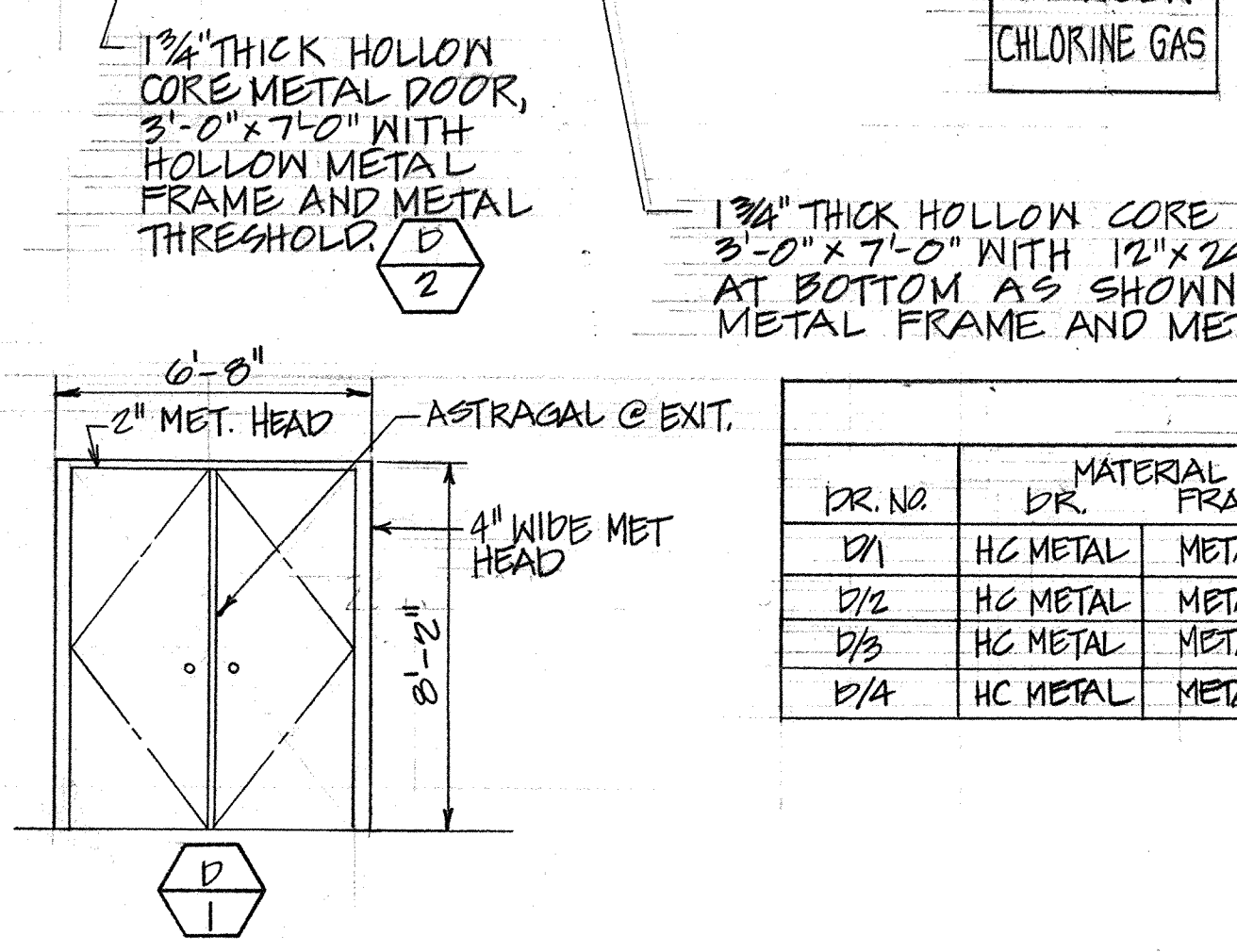
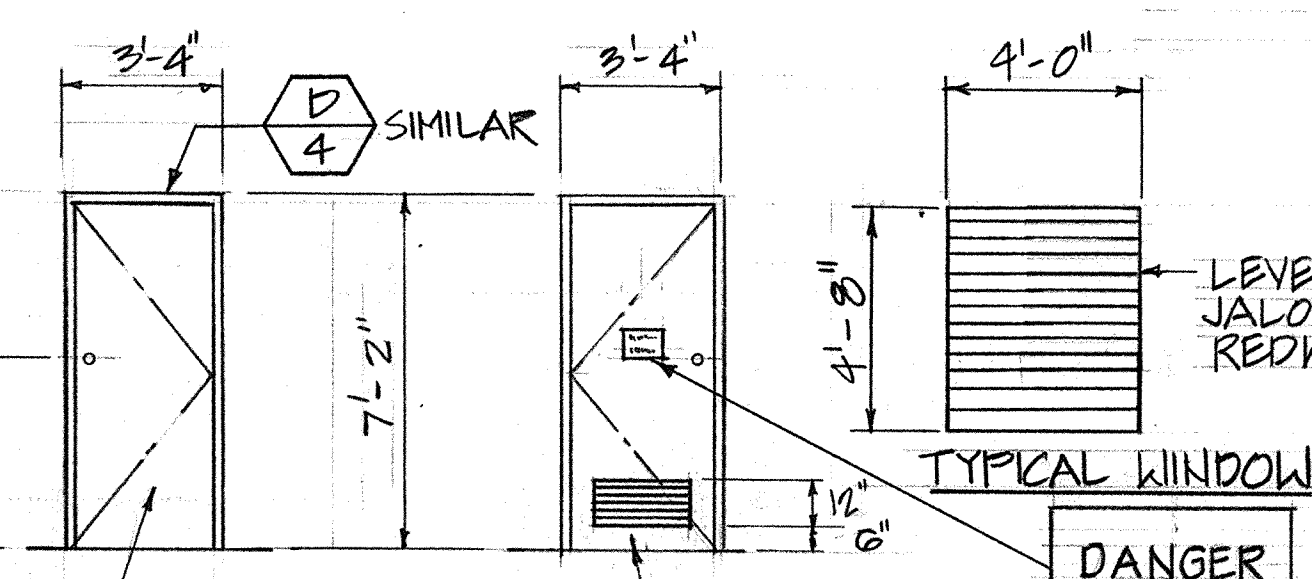

DOOR AND WINDOW DETAIL
SCALE: 1/4" = 1'-0"

SIGN NOTES:
1. SIGN TO BE 10GA. ALUMINUM W/8 MIL. ANOD AA-M21-C-21-A41 (7"x10") IN ACCORDANCE WITH OSHA CHAPTER 221
2. LETTERS SHALL BE RED ON WHITE BACKGROUND
3. FOR BALANCE OF FIN. HARDWARE SEE SPECS.
4. PROVIDE WARNING SIGN ON DOOR TO CHLORINATOR ROOM.

DR. NO.	MATERIAL	FRAME	SIZE	HARDWARE NO.	REMARKS
D/1	HC METAL	METAL	3'-0" x 8'-0"	HW 1	DOUBLE DOOR
D/2	HC METAL	METAL	3'-0" x 7'-0"	HW 2	
D/3	HC METAL	METAL	3'-0" x 7'-0"	HW 3	
D/4	HC METAL	METAL	2'-0" x 7'-0"	HW 4	GAS SEAL BY MFG.

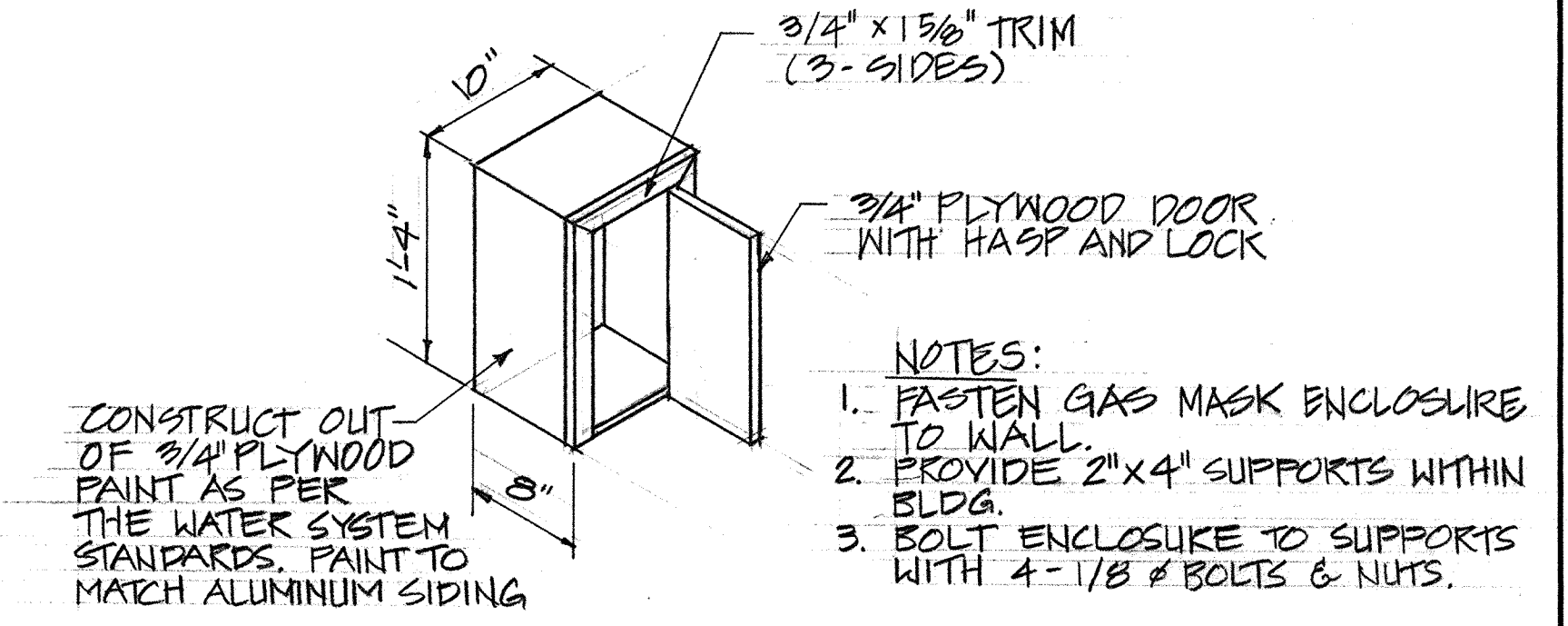

GAS MASK ENCLOSURE DETAIL
NOT TO SCALE

NOTES:
1. FASTEN GAS MASK ENCLOSURE TO WALL.
2. PROVIDE 2"x4" SUPPORTS WITHIN BLDG.
3. BOLT ENCLOSURE TO SUPPORTS WITH 4-1/8" BOLTS & NUTS.

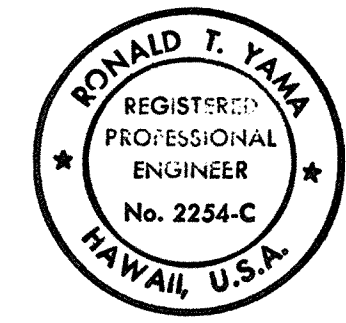

THIS WORK WAS PREPARED BY ME OR UNDER MY SUPERVISION.
Bonnie Yama

REVISION DATE	DESCRIPTION	MADE BY	APPROVED
AKINAKA & ASSOCIATES, LTD. CONSULTING ENGINEERS			
JOB NO. 85-5 PUMP, CONTROLS, PUMPHOUSE AND CONNECTING PIPELINE FOR MAKALEHA WELL NO. 0623-04 KAPAA WATER SYSTEM KAPAA, KAUAI, HAWAII			
CONTROL BUILDING MISCELLANEOUS DETAILS			
APPROVED: <i>Raymond H. Hays</i> MANAGER & CHIEF ENGINEER, DEPT. OF WATER SUPPLY			DATE: 7-1-87

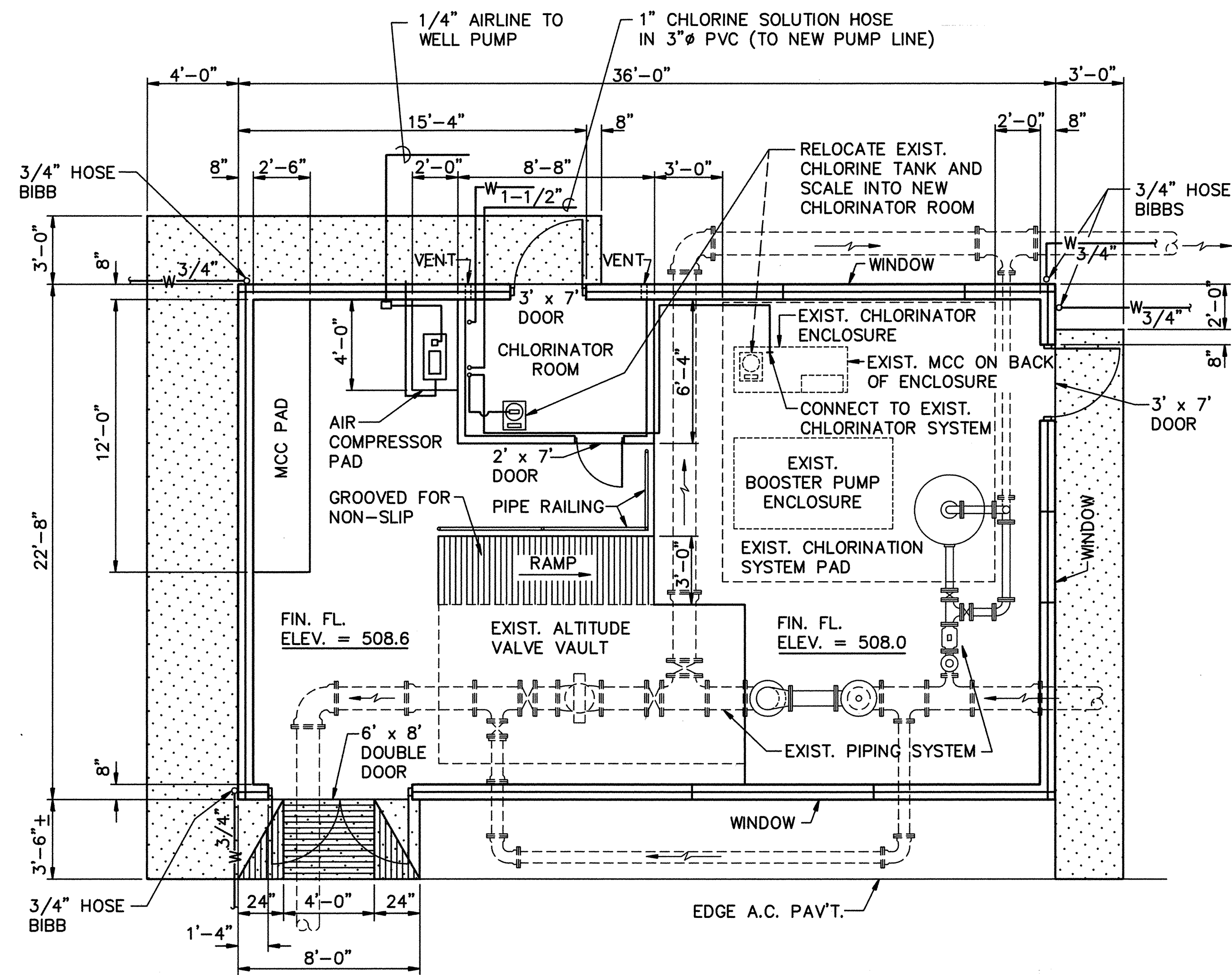

CONTROL BUILDING PIPING PLAN 1
SCALE: 1/4" = 1'-0"

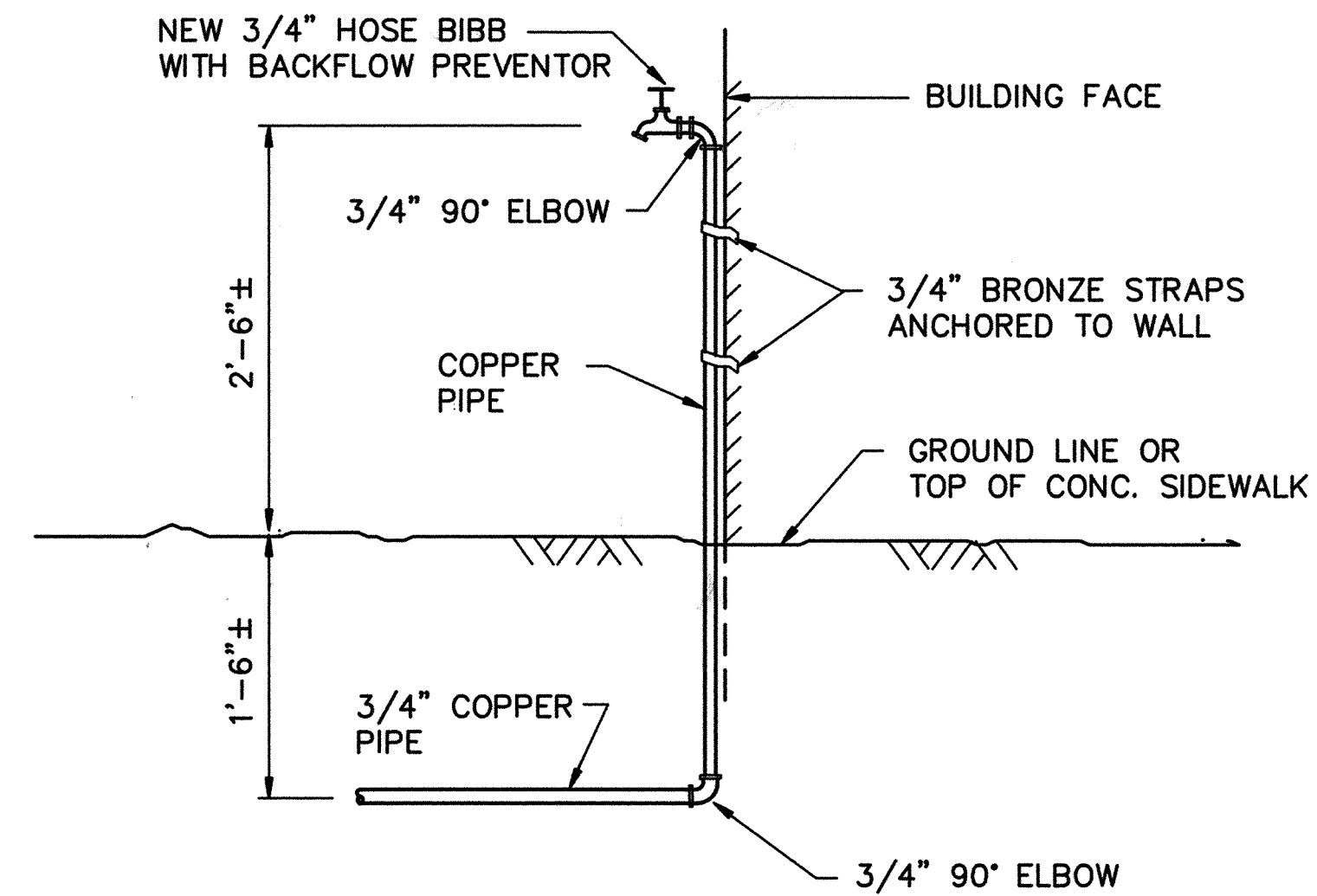

HOSE BIBB SUPPORT DETAIL-NEXT TO BLDG. 5
NOT TO SCALE

NOTES:
1. HOSE BIBB SHALL BE INSTALLED WITH APPROVED NON-REMOVABLE BACKFLOW PREVENTORS, AS PER SECTION 1003 (I) OF THE 1979 UNIFORM PLUMBING CODE

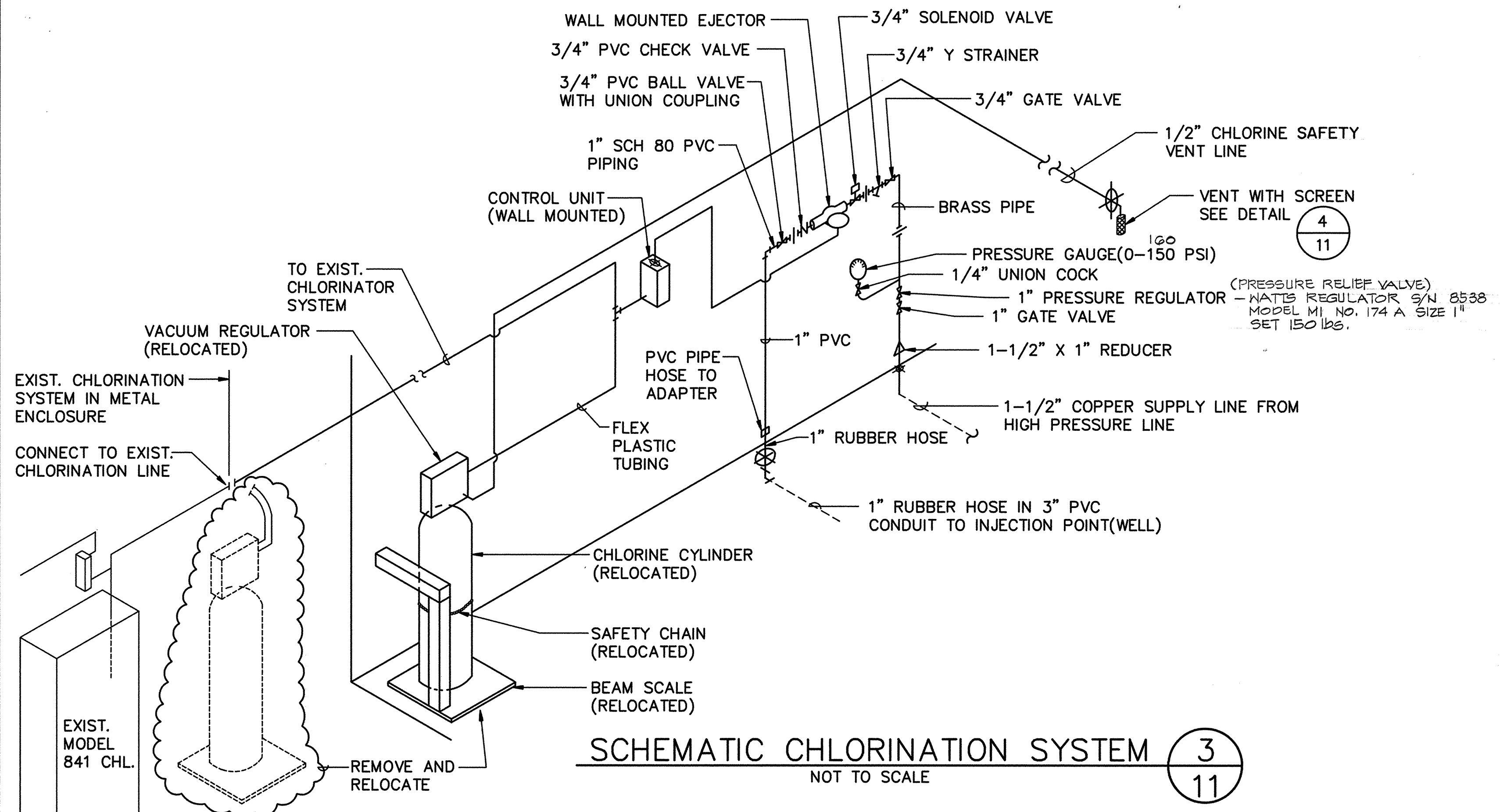

SCHEMATIC CHLORINATION SYSTEM 3
NOT TO SCALE

MATERIAL LIST	
ITEM NO.	DESCRIPTION
1	OUTLET VALVE
2	1/2" REGULATOR SET @ 90 PSI
3	FLEXIBLE CONNECTION
4	1/4" GLOBE VALVE
5	3 1/2" PRESSURE GAUGE (5-200 PSI) ASHCROFT DURAGAGE OR EQUAL
6	1/2" BRONZE GLOBE VALVE
7	BRASS UNION
8	COPPER TO BRASS ADAPTER
9	1/2" BRONZE GLOBE VALVE
10	FLOW METER WITH INTEGRAL DIFFERENTIAL PRESSURE REGULATOR
11	LIQUID LEVEL RECORDER (INSTRUMENT PANEL) 0 TO 450 FT.

- NOTES:
- RECEIVER TANK SHALL BE ASME STAMPED AND REGISTERED WITH THE NATIONAL BOARD.
 - INSPECTION PLUGS SHALL BE LOCATED TO PROVIDE EASY ACCESS FOR INSPECTION AND REPAIR.

COMPRESSOR MOTOR
MARATHON ELECTRIC CAT. NO. I III
MODEL UVB 145 TCR526 AA L
FR-145-T-85
1/2 HP 1725 RPM 1725
VOLT 115/208-230, FLA 18/9-3-9
SF 1.15, COPE J, AMP 40°C, INS B
DUTY-CONT. DES. L

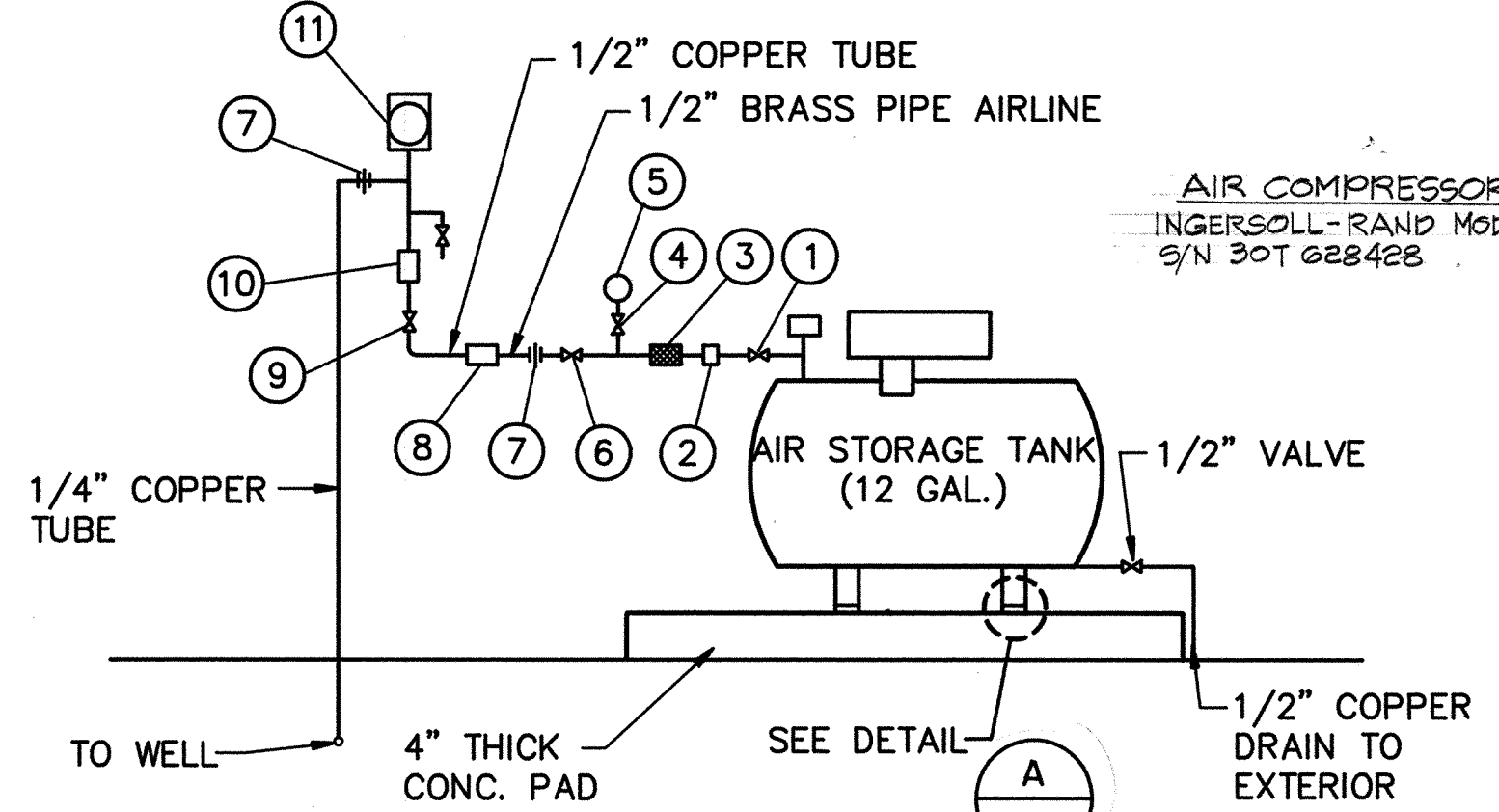

SCHEMATIC AIR PIPING SYSTEM 2
NOT TO SCALE

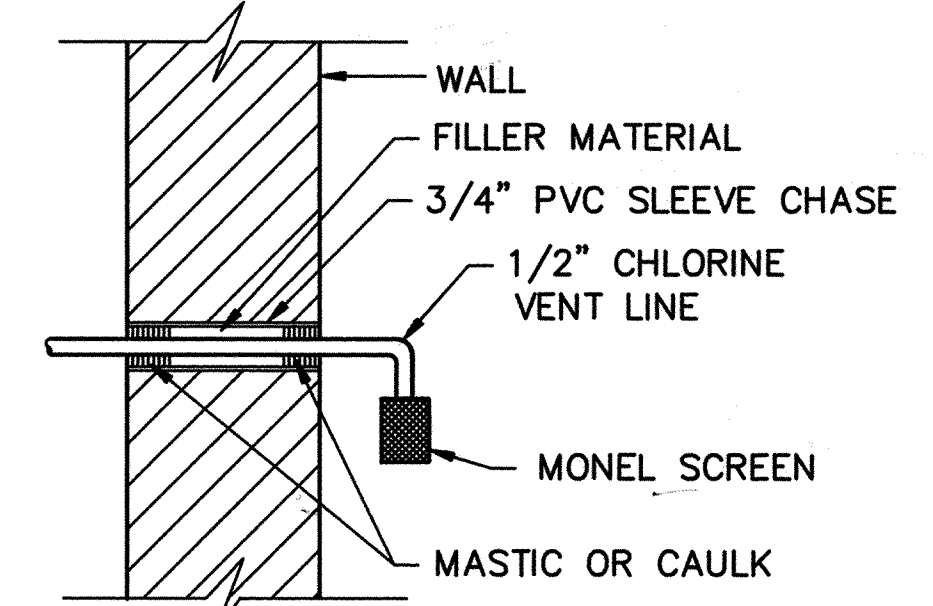

VENT DETAILS 4
NOT TO SCALE

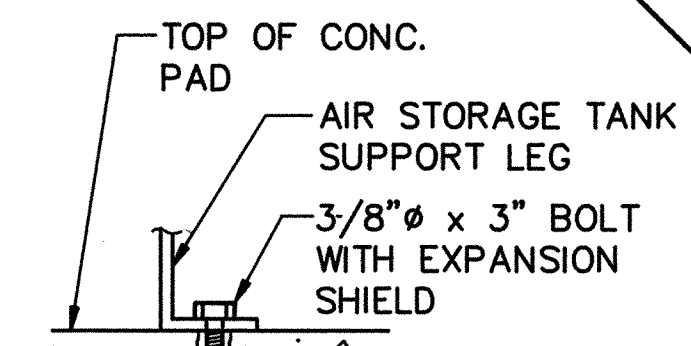

DETAIL A
NOT TO SCALE

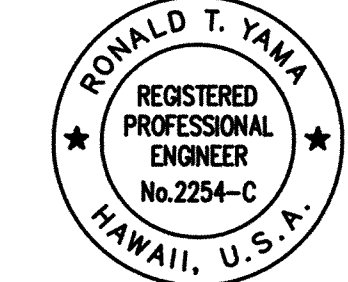

THIS WORK WAS PREPARED BY ME OR UNDER MY SUPERVISION
Ronald T. Yama

REVISION DATE	DESCRIPTION	MADE BY	APPROVED

AKINAKA & ASSOCIATES, LTD.
CONSULTING ENGINEERS
JOB NO. 85-5
PUMP, CONTROLS, PUMPHOUSE AND CONNECTING PIPELINE FOR MAKALEHA WELL NO. 0623-04
KAPAA WATER SYSTEM
KAPAA, KAUAI, HAWAII

CONTROL BUILDING PIPING DETAILS

APPROVED: *Raymond H. Pava* 7-1-87
MANAGER & CHIEF ENGINEER, DEPT. OF WATER SUPPLY DATE

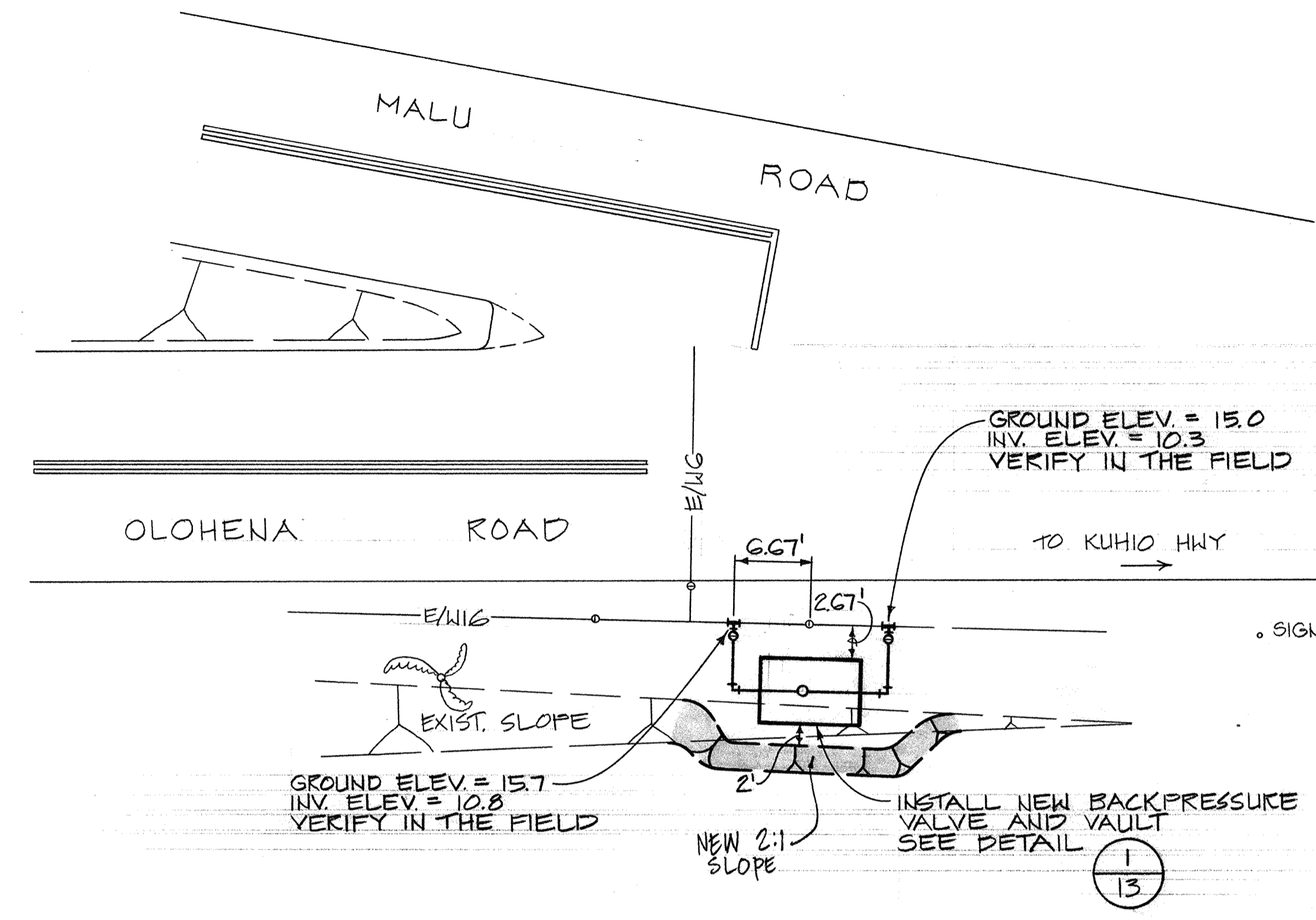
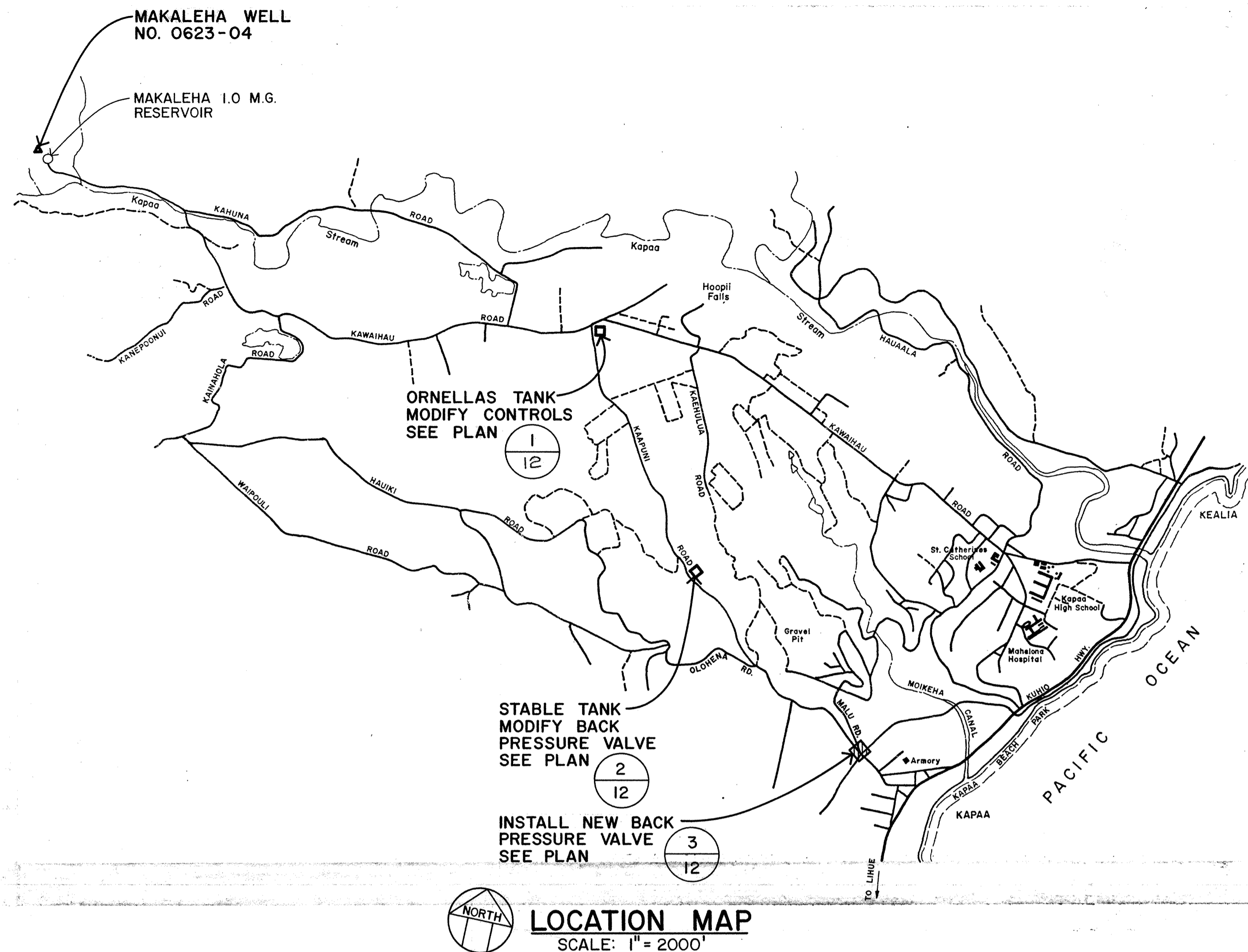

APPROVED:

COUNTY ENGINEER, DEPT. OF PUBLIC WORKS
COUNTY OF KAUAI

DATE

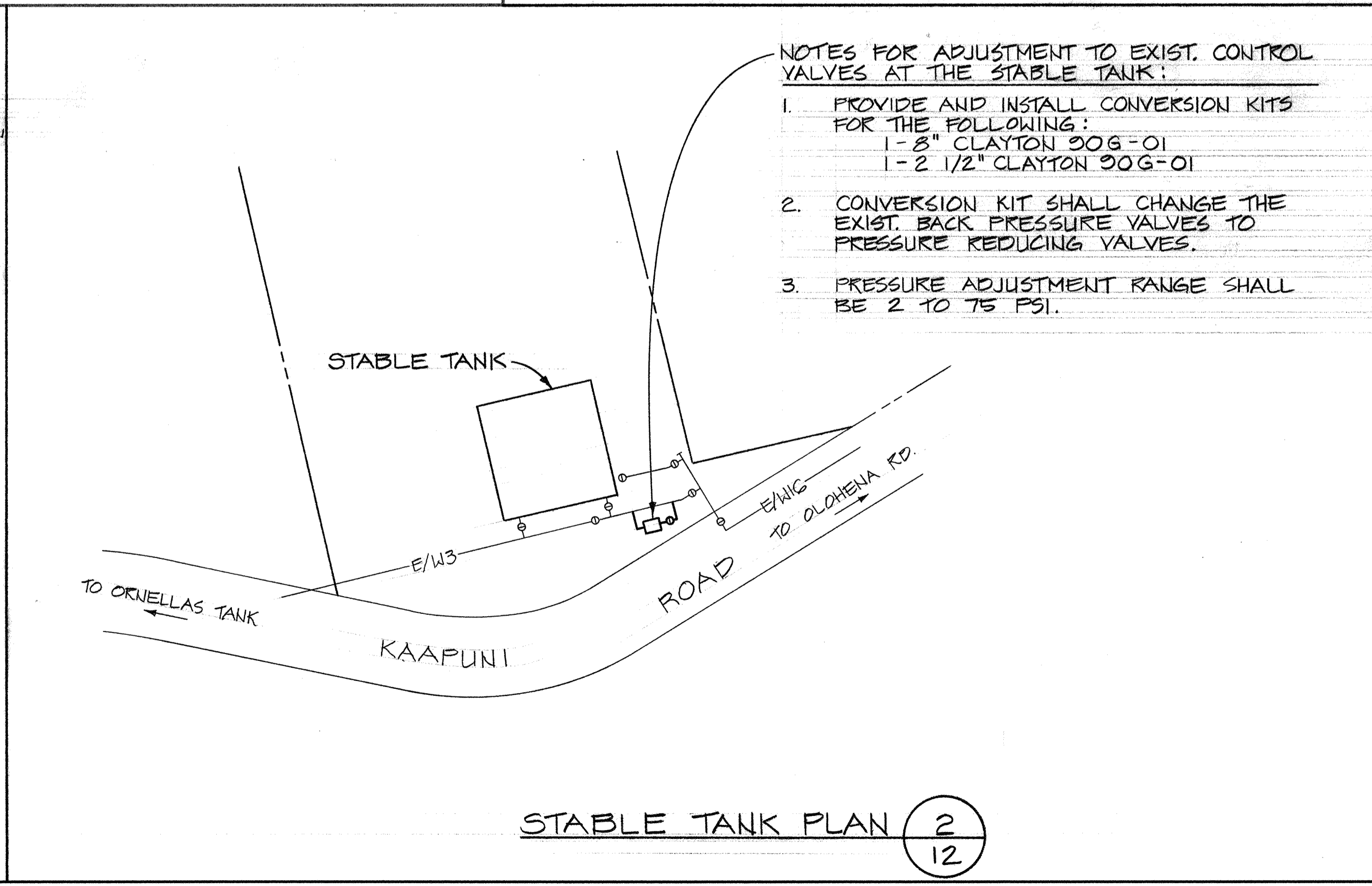
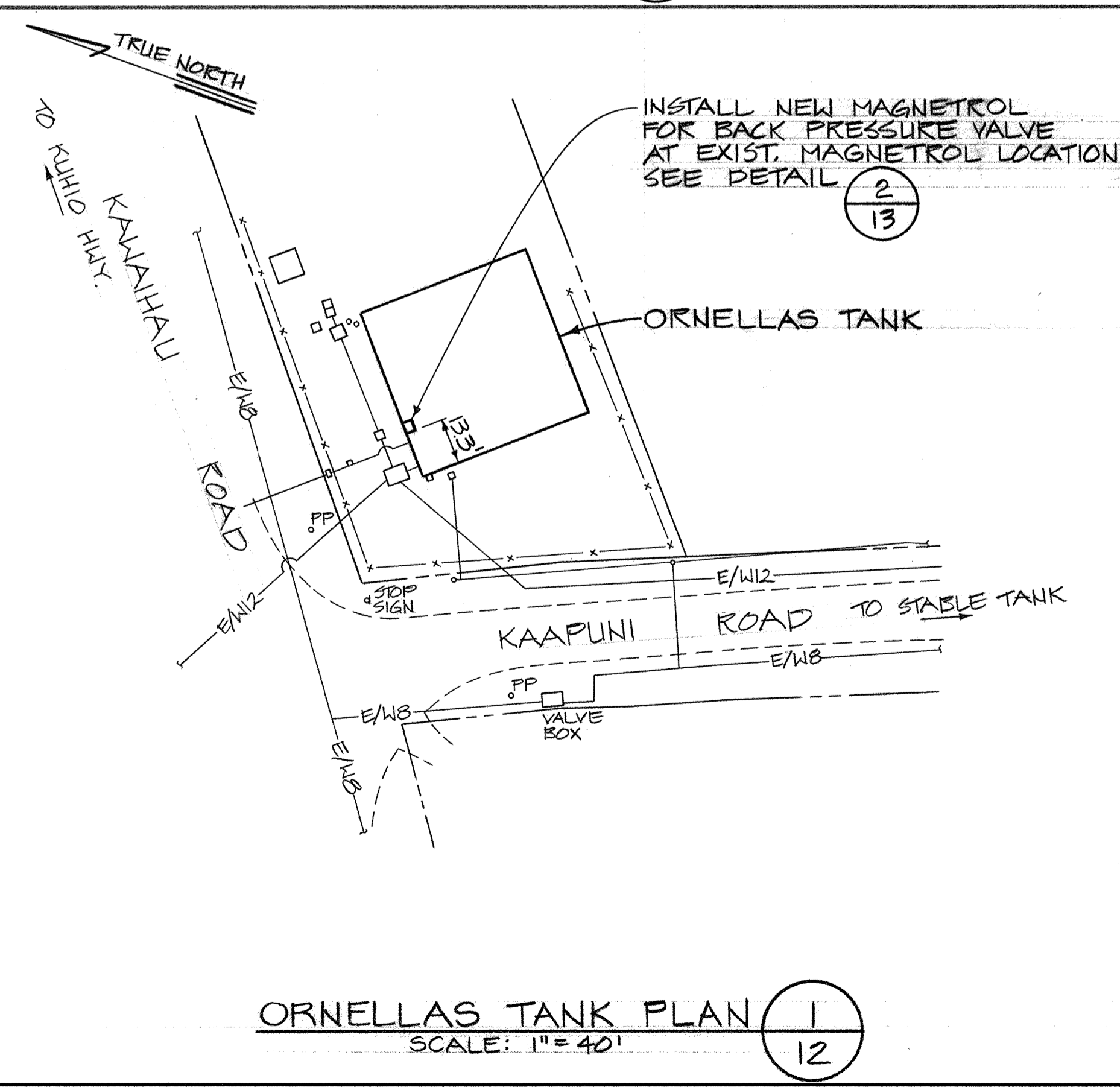

RONALD T. YAMA
REGISTERED PROFESSIONAL ENGINEER
No. 2254-C
HAWAII U.S.A.

THIS WORK WAS PREPARED BY ME OR UNDER MY SUPERVISION.

Ronald T. Yama

REVISION DATE	DESCRIPTION	MADE BY	APPROVED

AKINAKA & ASSOCIATES, LTD.
CONSULTING ENGINEERS

JOB NO. 85-5
PUMP, CONTROLS, PUMPHOUSE AND CONNECTING PIPELINE FOR MAKALEHA WELL NO. 0623-04
KAPAA WATER SYSTEM
KAPAA, KAUAI, HAWAII

BACK PRESSURE VALVE SYSTEM, LOCATION MAP & SITE PLAN

APPROVED: *Ronald T. Yama* 7-1-87
MANAGER & CHIEF ENGINEER, DEPT. OF WATER SUPPLY

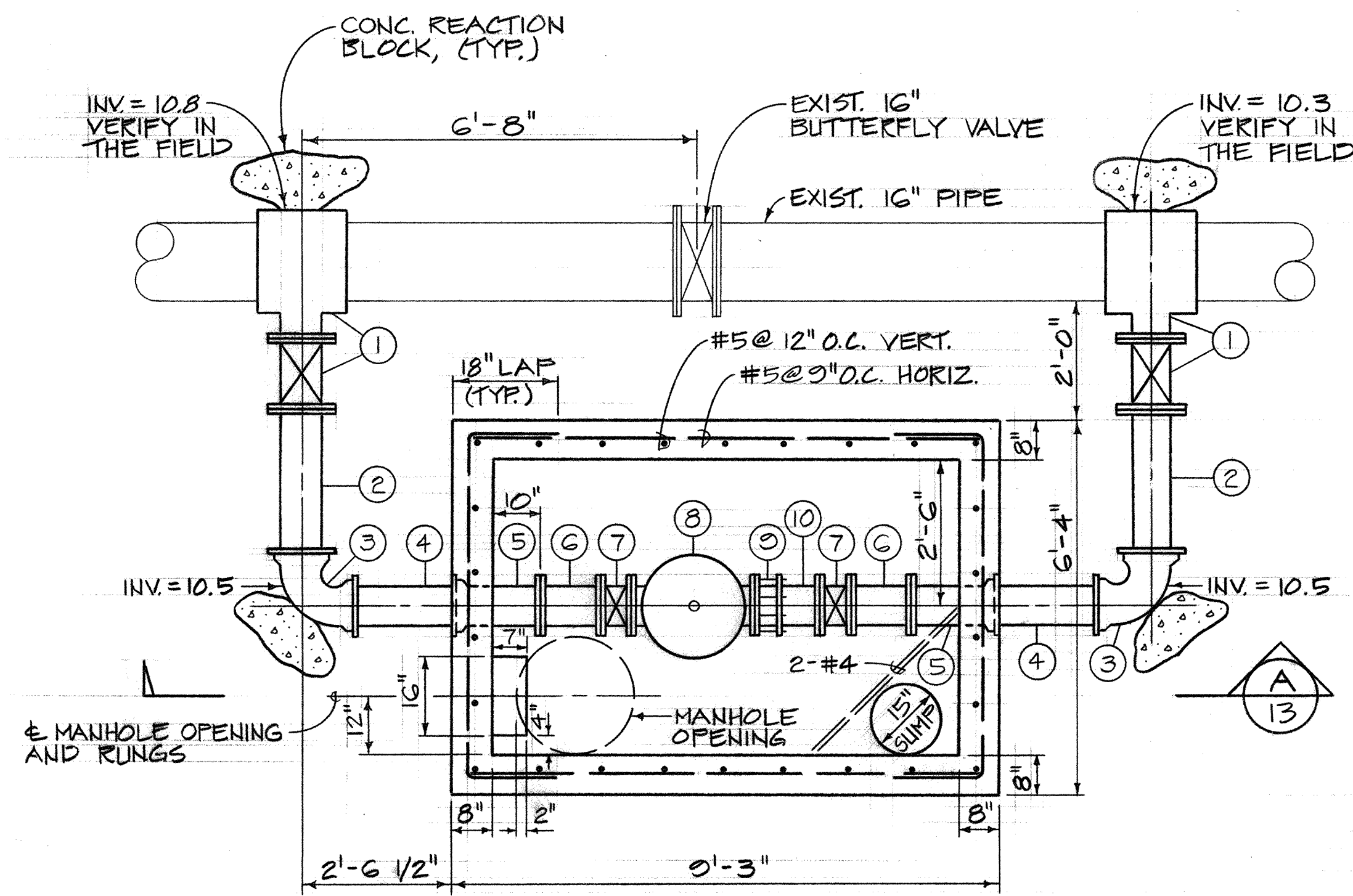

PLAN

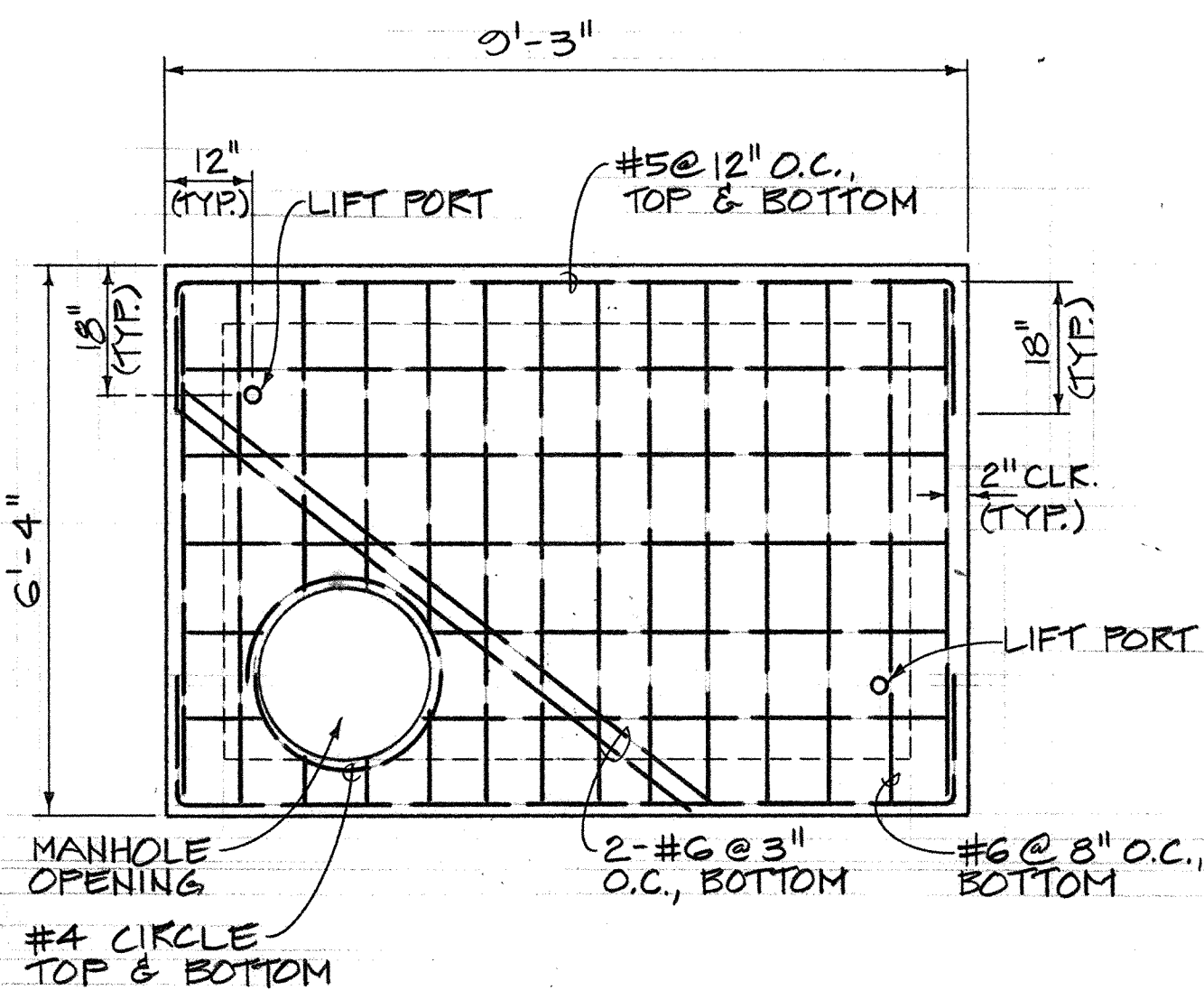

ROOF SLAB REINFORCING (B)
13

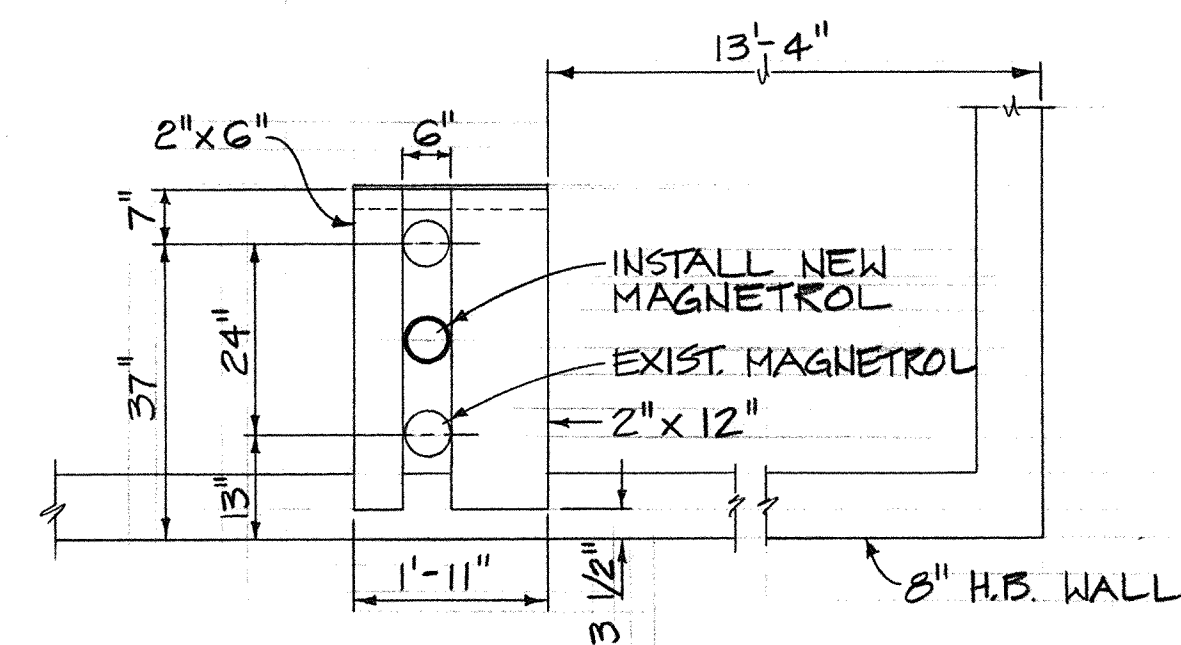

DETAIL PLAN 2
NOT TO SCALE 13

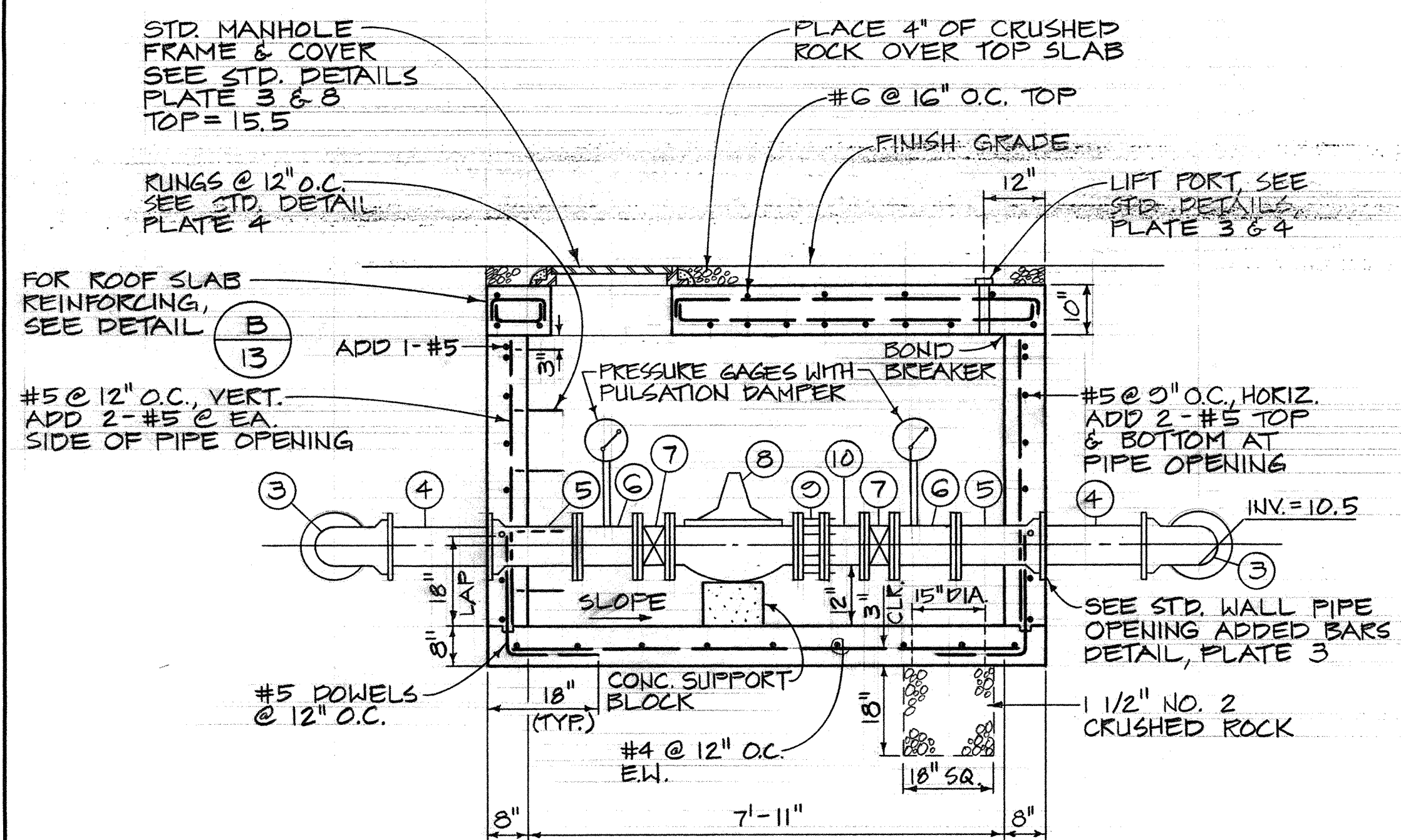

SECTION A (13)

BACK PRESSURE VALVE & VAULT DETAILS (1)
SCALE: 1/2" = 1'-0" 13

ITEM	QUANTITY	DESCRIPTION
①	2	16" x 8" ROMAL "SST" TAPPING SLEEVE & 8" TAPPING VALVE, FE. W/ CONC. REACTION BLOCK
②	2	8" D.I. PIPE, FE. x FE., 2'-7" LONG
③	2	8" 90° BEND, M.J. W/ CONC. REACTION BLOCK
④	2	8" D.I. PIPE, FE., 2'-0" LONG
⑤	2	8" D.I. PIPE, M.J. x FE., 1'-6" LONG
⑥	2	8" D.I. PIPE, FE. 12" LONG
⑦	2	8" BUTTERFLY VALVE, FE. WITH VALVE OPERATOR WHEEL (58) ⚠
⑧	1	8" BACK PRESSURE VALVE, CLAYTON 50/6-01 BS W/ X101 VALVE POSITION INDICATOR, FE.
⑨	1	8" FLANGED COUPLING ADAPTER, ROCKWELL NO. 912 OR APPROVED EQUAL
⑩	1	8" D.I. PIPE, FE. x FE., 12" LONG

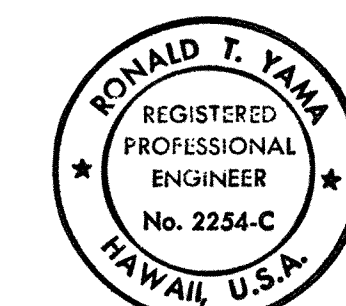

THIS WORK WAS PREPARED BY ME OR UNDER MY SUPERVISION.
Ronald T. Yama

REVISION DATE	DESCRIPTION	MADE BY	APPROVED
12/27/87	CHANGED 506-01 TO 506-01	RTY	<i>R. Yama</i>

AKINAKA & ASSOCIATES, LTD.
CONSULTING ENGINEERS
JOB NO. 85-5
PUMP, CONTROLS, PUMPHOUSE AND CONNECTING PIPELINE FOR MAKALEHA WELL NO. 0623-04
KAPAA WATER SYSTEM
KAPAA, KAUAI, HAWAII

BACK PRESSURE VALVE SYSTEM DETAILS

APPROVED: *Raymond L. Kama* 7-1-87
MANAGER / CHIEF ENGINEER, DEPT. OF WATER SUPPLY DATE

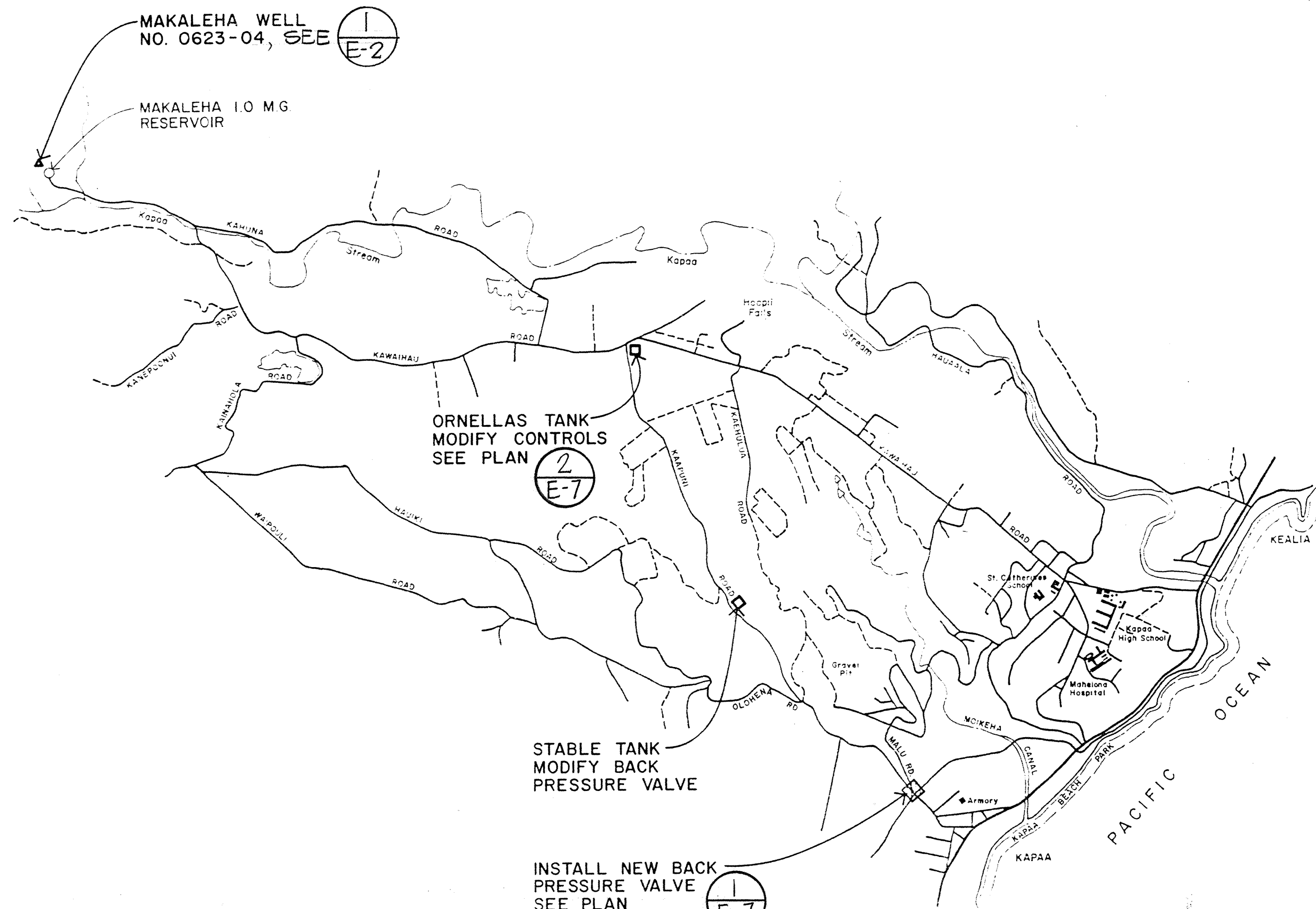

LOCATION MAP
SCALE: 1" = 2000'

EX. H.T. CO. CIRCUITS
MAKALEHA TANK ALARM-J95-2900
ORNELLAS TANK ALARM-J98-4150

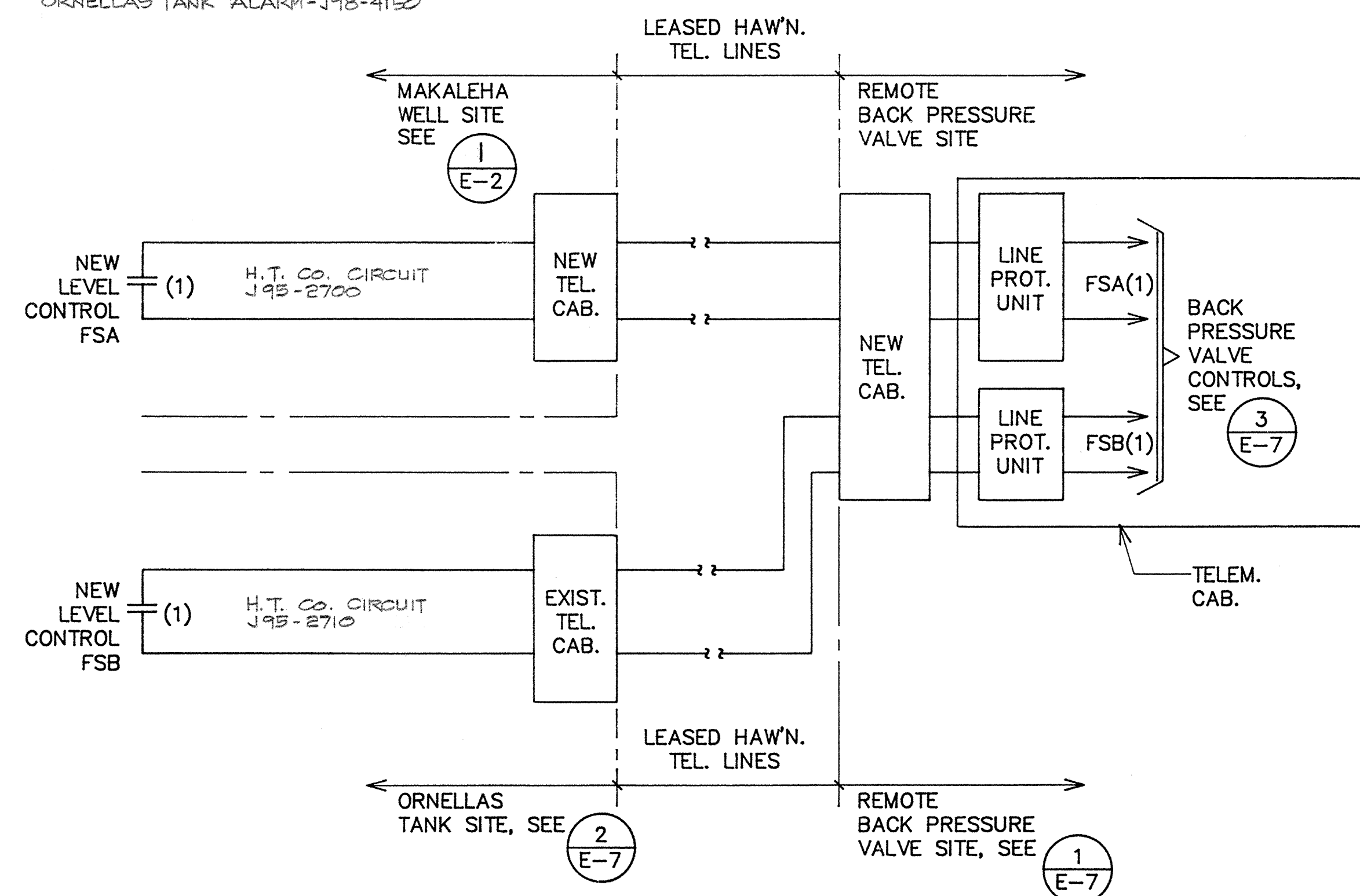

TELEMETERING CONTROL DIAGRAM
NOT TO SCALE

NOTES:

- CONTRACTOR SHALL OBTAIN SERVICE DRAWINGS FROM THE KAUAI ELECTRIC CO. AND THE HAWAIIAN TELEPHONE CO.; UTILITY CO. DRAWINGS SHALL BECOME PART OF THE CONTRACT DOCUMENTS AND SHALL SUPERCEDE REQUIREMENTS OF THESE DRAWINGS.
- BOARD OF WATER SUPPLY WILL PAY FOR ALL UTILITY NON-RECURRING COSTS FOR SERVICE INCLUDING ANY EXTENSION WORK OF THEIR EXISTING NETWORK SYSTEM.
- CONTRACTOR SHALL COORDINATE ALL WORK WITH THE KAUAI ELECTRIC CO. AND THE HAWAIIAN TELEPHONE CO.
- PROVIDE POLYOLEFIN 200LB TEST PULLWIRE IN ALL EMPTY CONDUITS.

BACKFILL NOTES:

- TYPE "A" BACKFILL - EARTH & GRAVEL. ROCK SIZE TO BE 1" & THE MIXTURE TO CONTAIN NOT MORE THAN 50% BY VOLUME OF ROCK PARTICLES. 95% COMPACTION.
- TYPE "B" BACKFILL - EARTH & GRAVEL. MIXTURE MUST PASS A 1/2" MESH SCREEN & CONTAIN NOT MORE THAN 20% BY VOLUME OF ROCK PARTICLES. 95% COMPACTION.
- NOTE - IF NORMAL MATERIAL AT BOTTOM OF TRENCH IS NOT TYPE "B", AN ADDITIONAL 3" SHALL BE EXCAVATED & TYPE "B" BACKFILL PROVIDED.
- CONCRETE - 3" ENCASEMENT, 3000 PSI COMPRESSIVE STRENGTH IN 28 DAYS.

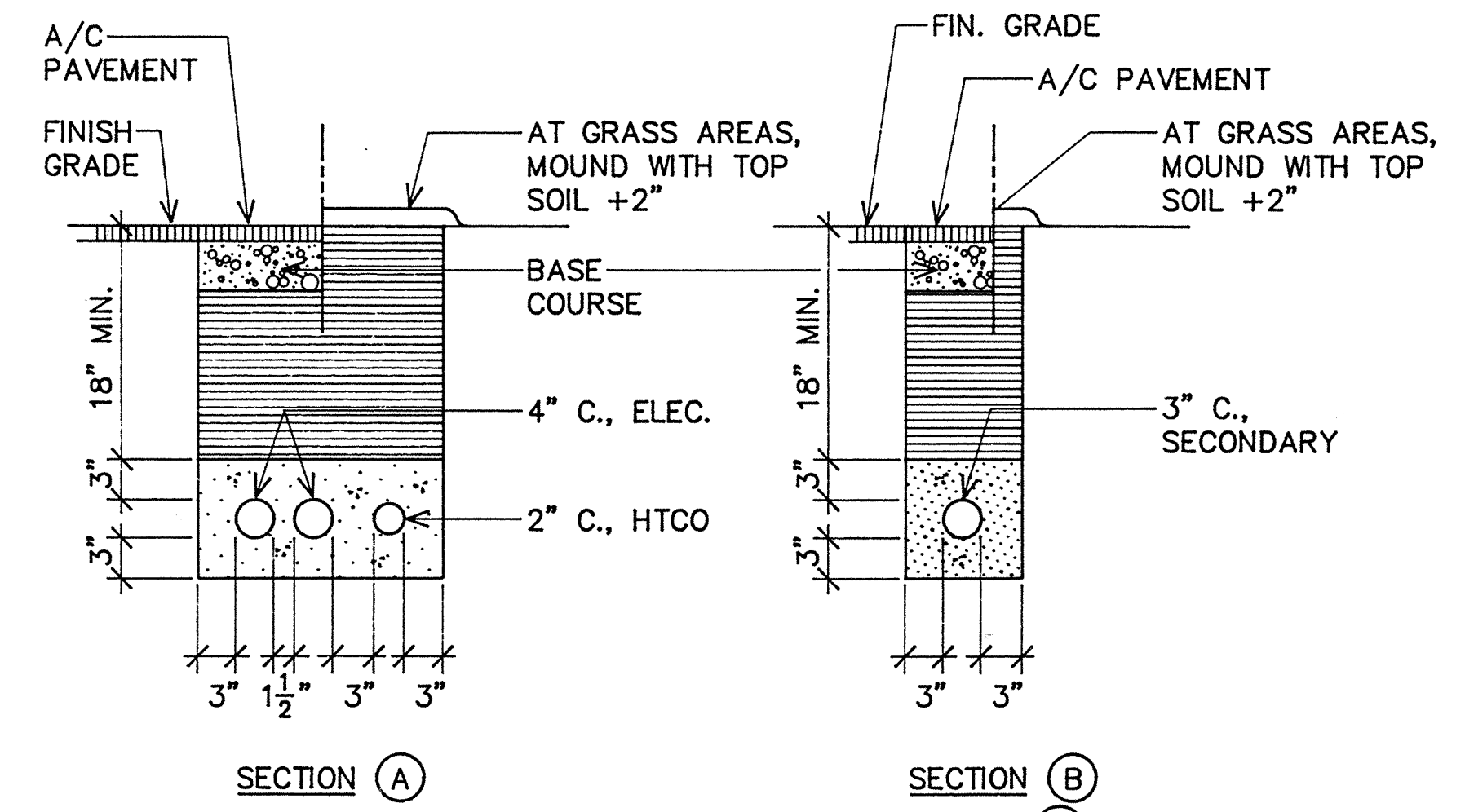

DUCT SECTIONS

NOT TO SCALE

- DUCT SECTION NOTES:**
- PROVIDE 6" MINIMUM SEPARATION BETWEEN CONCRETE JACKET AND WATERLINE. ONLY SELECT BACKFILL MATERIAL SHALL BE USED AROUND WATERLINES.

ELECTRICAL SYMBOLS

SYMBOL	DESCRIPTION
	FLUOR. LIGHT, CEIL. MTD.
	HPS NIGHT LIGHT, WALL MTD.
	LT. SW., 1P, CONTROLLING OUTLET(S) "a", MTD. +48"
	DUPLEX RECEPTACLE, NEMA 5-15R, 120V, MTD. +12" OR AS NOTED
	DUPLEX RECEPTACLE, NEMA 5-15R, 120V, CONNECTED TO GFI CKT., MTD. +24" OR AS NOTED
	TEL. OUTLET, MTD. +24"
	TEL. CAB., MTD. +72" TO TOP
	JUNCTION BOX, CEIL. MTD., 4-11/16" NOM.
	JUNCTION BOX, WALL MTD., 4-11/16" NOM.
	JUNCTION BOX MTD. ON RACEWAY RISER
	CLOCK OUTLET, MTD. +7'-6"
	MOTOR CONNECTION
	EQUIPMENT CONNECTION
	LIMIT SWITCH CONN. (BUTTERFLY VALVE MICROSWITCHES)
	SOLENOID VALVE CONNECTION
	FLOW SWITCH CONNECTION
	HEATER CONNECTION
	CONTROL VALVE CONNECTION
	COMBINATION MOTOR STARTER/NON-FUSIBLE DISCONNECT SWITCH
	DISCONNECT SWITCH, HP RATED
	FLEXIBLE CONDUIT, LIQUIDTITE
	CONDUIT BELOW REF. FL. OR GRD., 2 WIRES
	CONDUIT ABOVE REF. FL., 3 WIRES WITH GRD.
	EXISTING CONDUIT
	TELEPHONE CONDUIT
	(A-2/34) LIGHT FIXTURE DESIGNATOR, INDICATES TYPE "A" WITH 2-34 WATT LAMPS
	DUCT SECTION INDICATOR, SEE DETAILS THIS SHEET
	WP DENOTES "WEATHERPROOF"

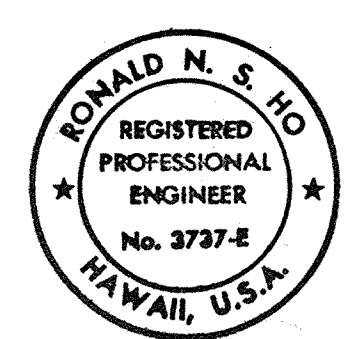

THIS WORK WAS PREPARED BY ME OR UNDER MY SUPERVISION.
Ronald N. S. Ho

REVISION DATE	DESCRIPTION	MADE BY	APPROVED
11-23-87	ADD DUCT SEC. D NOTE	R. HO	<i>R. Ho</i>

AKINAKA & ASSOCIATES, LTD.
CONSULTING ENGINEERS

JOB NO. 85-5
PUMP, CONTROLS, PUMPHOUSE AND CONNECTING PIPELINE FOR MAKALEHA WELL NO. 0623-04
KAPAA WATER SYSTEM
KAPAA, KAUAI, HAWAII

LOCATION MAP, SYMBOLS, DUCT SECTIONS, TELEMETERING DIAGRAM

APPROVED: *Ronald N. S. Ho* 7-1-87
MANAGER, CHIEF ENGINEER, DEPT. OF WATER SUPPLY

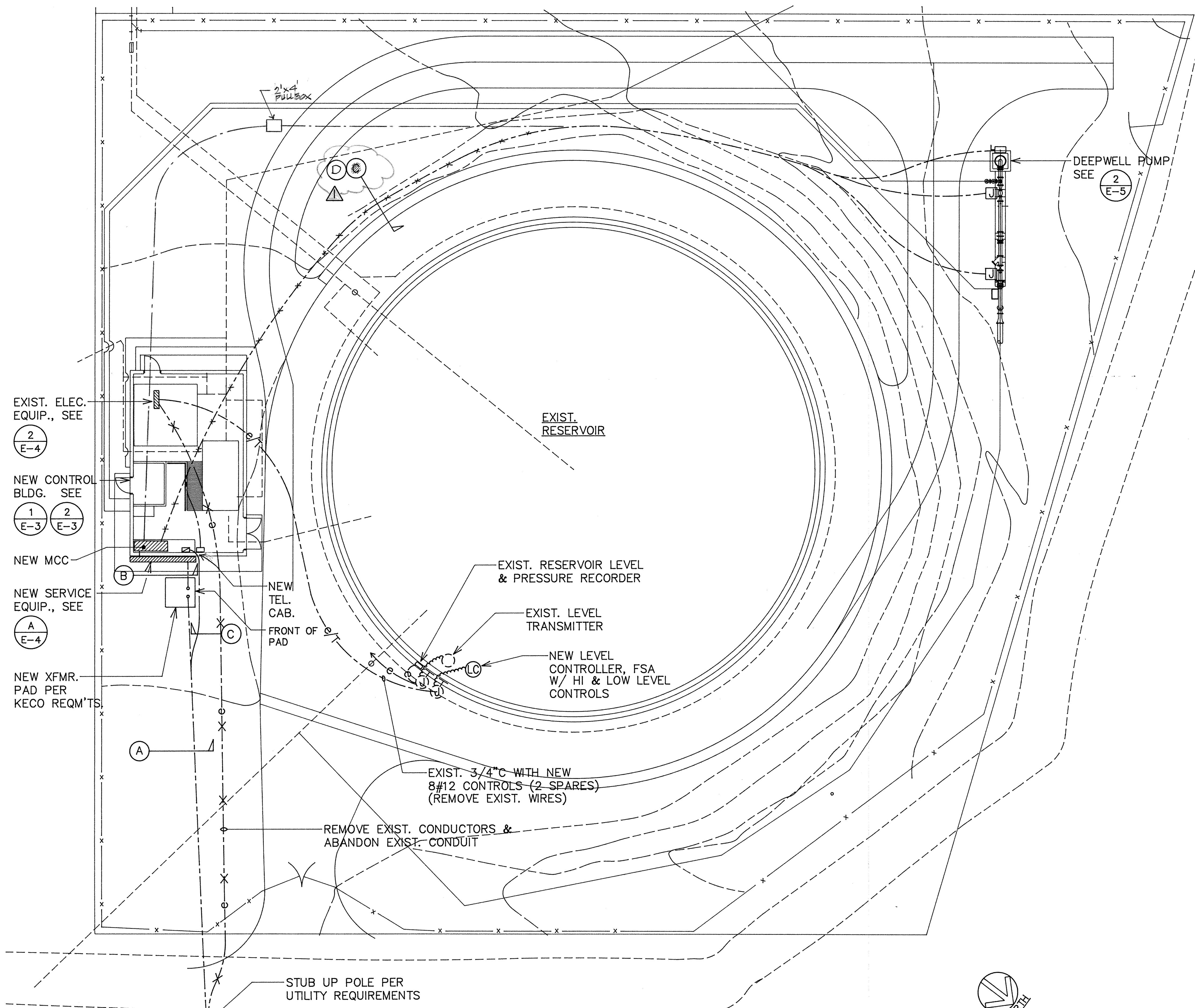

- EXIST. ELEC. EQUIP., SEE 2 E-4
- NEW CONTROL BLDG. SEE 1 E-3 2 E-3
- NEW MCC
- NEW SERVICE EQUIP., SEE A E-4
- NEW XFMR. PAD PER KECO REQM'TS

1 **ELECTRICAL SITE PLAN - MAKALEHA WELL**
E-2 SCALE: 1" = 10'-0"

E-2

THIS WORK WAS PREPARED BY ME OR UNDER MY SUPERVISION.
Ronald N. S. Ho 5/13/87

REVISION DATE	DESCRIPTION	R. HO	APPROVED
11-23-87	CLARIFIED DUCT SEC.	R. HO	<i>R. Ho</i>
AKINAKA & ASSOCIATES, LTD. CONSULTING ENGINEERS JOB NO. 85-5 PUMP, CONTROLS, PUMPHOUSE AND CONNECTING PIPELINE FOR MAKALEHA WELL NO. 0623-04 KAPAA WATER SYSTEM KAPAA, KAUAI, HAWAII ELECTRICAL SITE PLAN - MAKALEHA WELL			
APPROVED: <i>Raymond U. Iwata</i> MANAGER & CHIEF ENGINEER, DEPT. OF WATER SUPPLY		DATE: 7-1-87	NO.

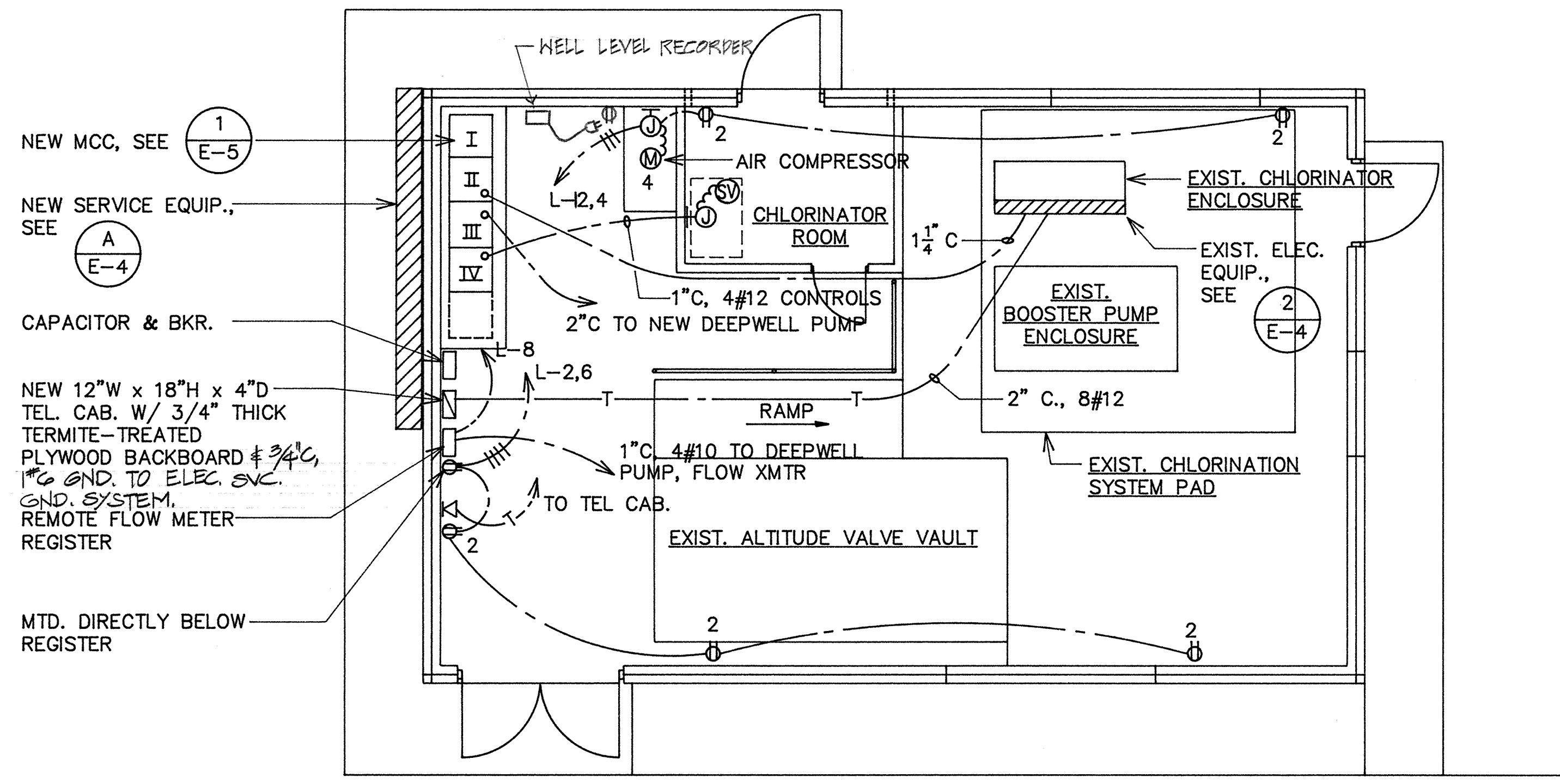

1 CONTROL BLDG. POWER & SIGNAL PLAN
E-3
SCALE: 1/4" = 1'-0"

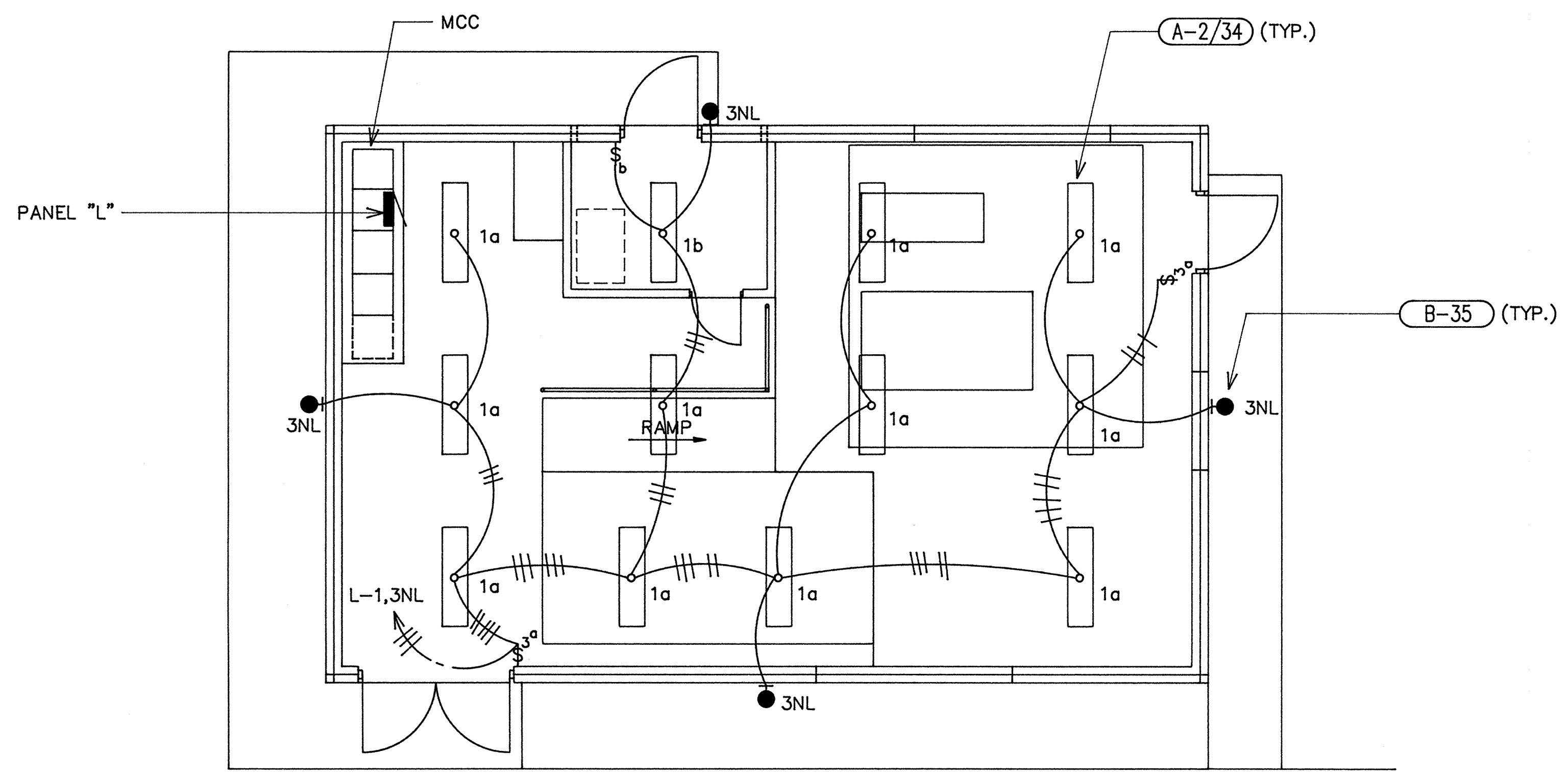

2 CONTROL BLDG. LIGHTING PLAN
E-3
SCALE: 1/4" = 1'-0"



PANEL L						
240/120V, 1φ, 3W, 2P100A MAIN BKR						
FLUSH MTD. IN MCC, INDUSTRIAL-BOLTED						
CKT. NO.	BREAKERS	USE: L-LTS., R-RECEP., S-SPARE, PFB-PROV. FUT. BKR.	KVA LOADS			WIRE SIZE
			A	B	C	
1	1	20	CONTROL CKT.			12
2			R			12
3			EXTERIOR LT., NL			12
4			AIR COMPRESSOR			12
5			SPARE			10
6			R - REMOTE METER REGISTER			12
7			PUMP TEST CKT.			12
8		20	FLOW METER/XMTR POWER			12
9			PFB INTERIOR LIGHTS			
10			R			
11						
12			WELL LEVEL RECORDER			
13						
14						
15						
16						
17						
18						
19						
20		70	PNL "P"			
21	1		PFB			
22	2	70	EXIST. PNL. "P"			4
23	1		PFB			
24		100	(PART OF CKT. 22) MAIN			4
25						
26		100	MAIN			
TOTAL LOAD PER LEG			9.4	7.6		
TOTAL CONNECTED LOAD			17.0			
DEMAND FACTOR			70%			
TOTAL DEMAND LOAD			11.9			

LIGHTING LIMIT CALCULATIONS					
ROOMS	AREA (SF)	WATTS PER SF	WATTS PER LF	ALLOWED WATTS	ACTUAL WATTS
CONTROL	747	3		2241	1100
CHLORINATOR	81	3		243	100
EXTERIOR	118		5	590	200
TOTAL				3074	1400

LIGHT FIXTURE SCHEDULE				
TYPE	LAMPS	MOUNTING	DESCRIPTION	MANUF. OR APPR. EQ.
A	2-34 WATT, LN, RS, ENERGY SAVING TYPE	CEILING SURFACE	1' X 4' FLUORESCENT WRAPAROUND WITH ACRYLIC PRISMATIC DIFFUSER, ALUM. DOOR FRAME, BAKED WHITE ENAMEL FINISH, 120 VOLT ENERGY SAVING BALLAST.	GLOBE 3700 SERIES, COLUMBIA, DAYBRITE
B	1-35 WATT, HPS	WALL SURFACE @ 7'-6"	HIGH INTENSITY DISCHARGE WALLPACK WITH POLYCARBONATE REFRACTOR, CAST ALUM. HSG., AND FOUR TAMPERPROOF SCREWS, BRONZE FINISH. PROVIDE TWO TAMPERPROOF SCREWDRIVERS.	KENALL PROTECTOR 5200 SERIES, KEENE, LUMARK

E-3

REVISION DATE	DESCRIPTION	MADE BY	APPROVED

AKINAKA & ASSOCIATES, LTD.
CONSULTING ENGINEERS

JOB NO. 85-5
PUMP, CONTROLS, PUMPHOUSE AND CONNECTING PIPELINE FOR MAKALEHA WELL NO. 0623-04
KAPAA WATER SYSTEM
KAPAA, KAUAI, HAWAII

CONTROL BLDG ELEC. PLANS, SCHEDULES - MAKALEHA WELL

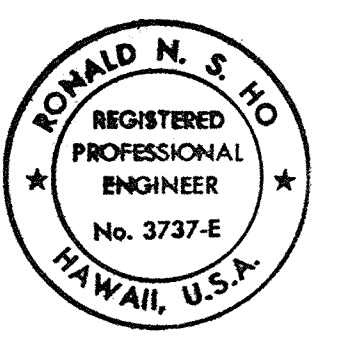

THIS WORK WAS PREPARED BY ME OR UNDER MY SUPERVISION.

Ronald N. S. Ho 5/13/87

APPROVED: *Raymond D. [Signature]* 7-1-87
MANAGER & CHIEF ENGINEER, DEPT. OF WATER SUPPLY

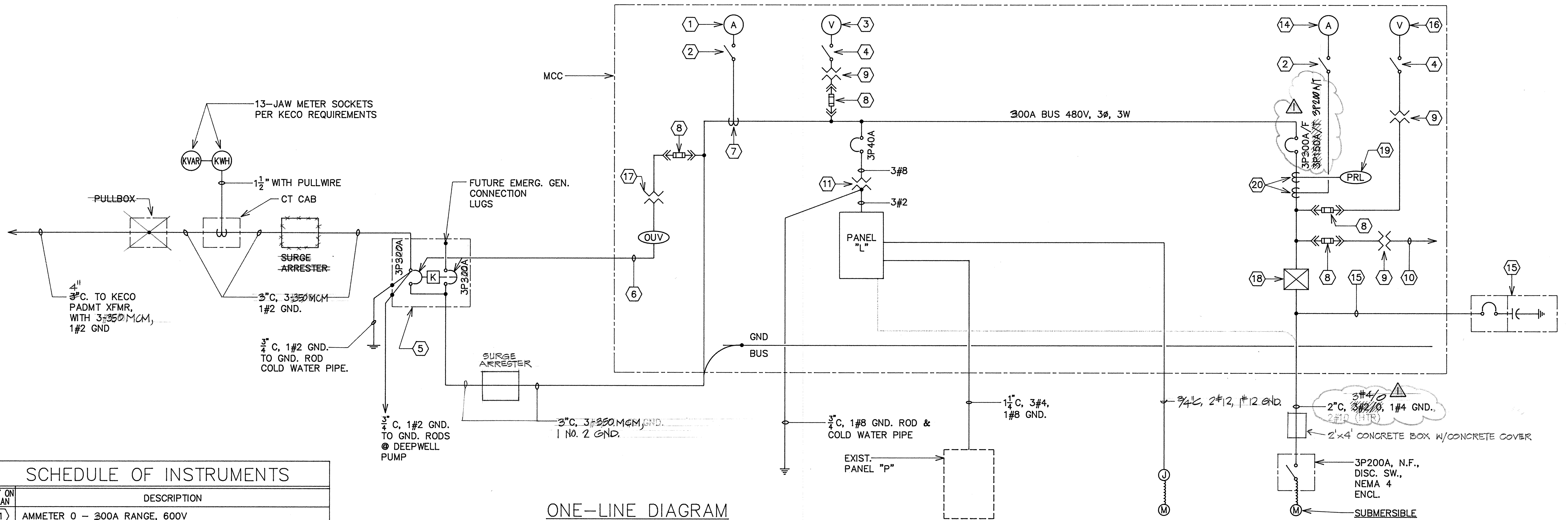

SCHEDULE OF INSTRUMENTS	
KEY ON PLAN	DESCRIPTION
1	AMMETER 0 - 300A RANGE, 600V
2	AMMETER SWITCH, 600V, 4 POSITION, "A", "B", "C", "OFF"
3	RECORDING VOLTMETER, 360/540V SELECTED FOR 480V, 3 PHASE, 4 WIRE, 60 HZ USE, SINGLE INPUT RECORDING
4	VOLTMETER SWITCH, 600V, 4 POSITION, "A", "B", "C", "OFF"
5	MANUAL TRANSFER SWITCH WITH 2-MOLDED CASE CKT BKRS, SIZE AS INDICATED WITH KIRK-KEY INTERLOCK FOR NORMAL OR EMERGENCY OPERATION. PROVIDE 4" HUB & CAP AT BOTTOM OF NEMA 3R ENCLOSURE FOR CABLE LUG CONNECTIONS TO EMERGENCY GENERATOR. BOTH BKRS SHALL BE PROVIDED WITH SHUNT TRIP COIL FOR CONNECTION TO OVER/UNDER VOLTAGE SYSTEM.
6	CONTROL WIRING TO SHUNT TRIP COILS OF BOTH MANUAL TRANSFER SWITCH BKRS, IN 3/4"C.
7	CURRENT TRANSFORMER, 600V, 300:5
8	FUSE HOLDER WITH FUSE, 600V, SIZE BY MANUFACTURER
9	POTENTIAL TRANSFORMER, 600V FOR 480V-120V
10	TO CONTROL CIRCUIT
11	DRY TYPE TRANSFORMER 25KVA 480-120/240V, 1Ø, 3W
12	
13	
14	AMMETER, 0 - 150A RANGE
15	CAPACITOR, CAPACITOR BREAKER AND WIRING PER PUMP MOTOR MANUFACTURER'S RECOMMENDATIONS
16	VOLTMETER 0-600V, SELECTED FOR 480V, 3 PHASE, 4 WIRE, 60 HZ. USE, SINGLE INPUT
17	CONTROL TRANSFORMER, 600V FOR 480-120V, 2 KVA
18	MOTOR STARTER, NEMA SIZE 4, AUTO-TRANSFORMER REDUCED VOLTAGE TYPE, (SIZED FOR FUTURE 100HP PUMP) HEATERS SELECTED TO MATCH MOTOR HORSEPOWER RATING AT 480V, 3 PHASE. (OF MOTOR BEING FURNISHED)
19	PHASE REVERSAL / LOSS RELAY (SEE SPECS)
20	CURRENT TRANSFORMER, 600V, 150:5

ONE-LINE DIAGRAM

NOTE: 1. MOTOR STARTER, CIRCUIT BREAKER, AMPERE FRAME, DISCONNECT SWITCH & WIRING FOR DEEPWELL PUMP HAVE BEEN SIZED FOR FUTURE SUBMERSIBLE 100 HP MOTOR.

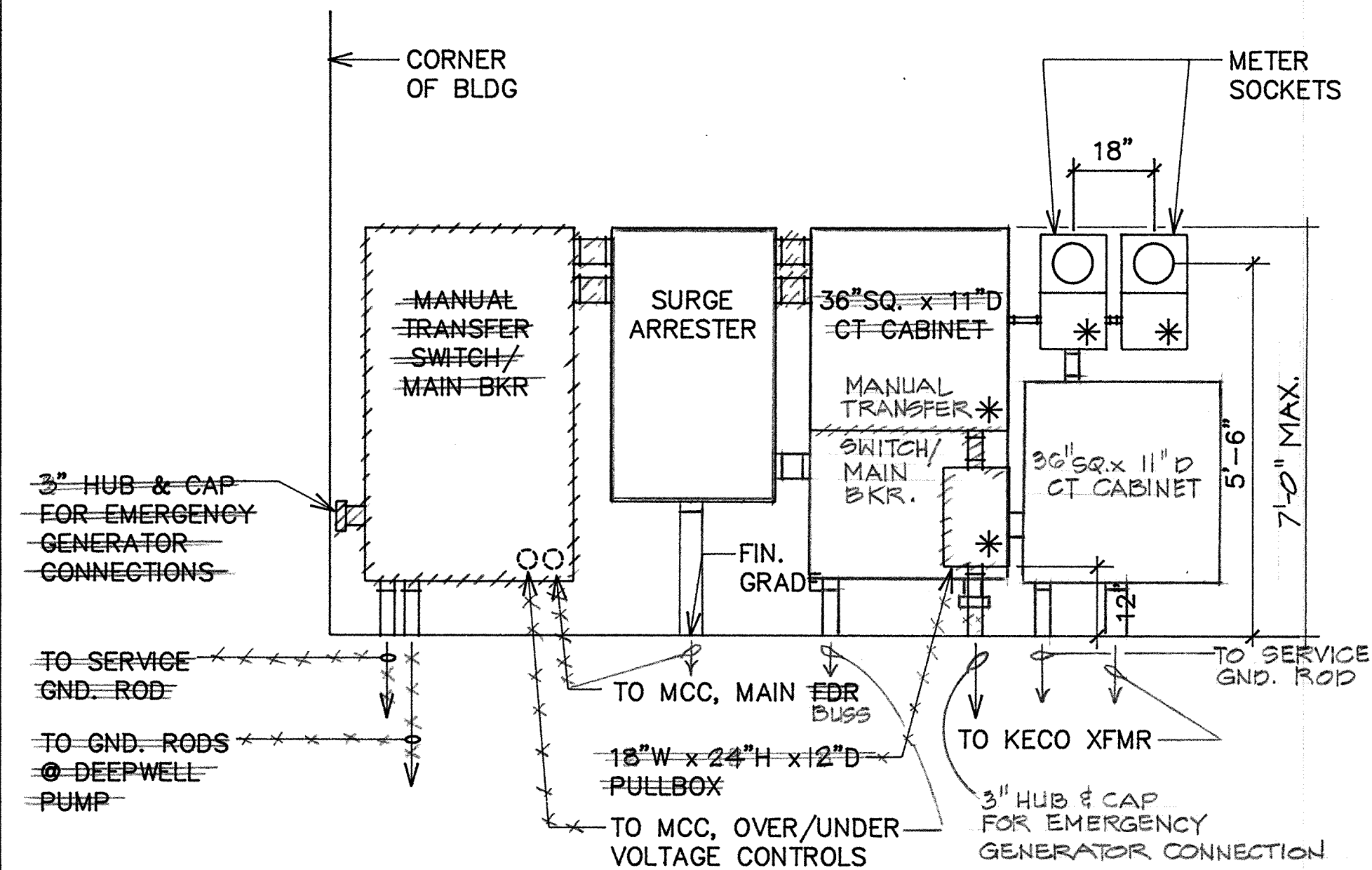

A ELEC. SERVICE EQUIP. ELEVATION

E-4 NTS

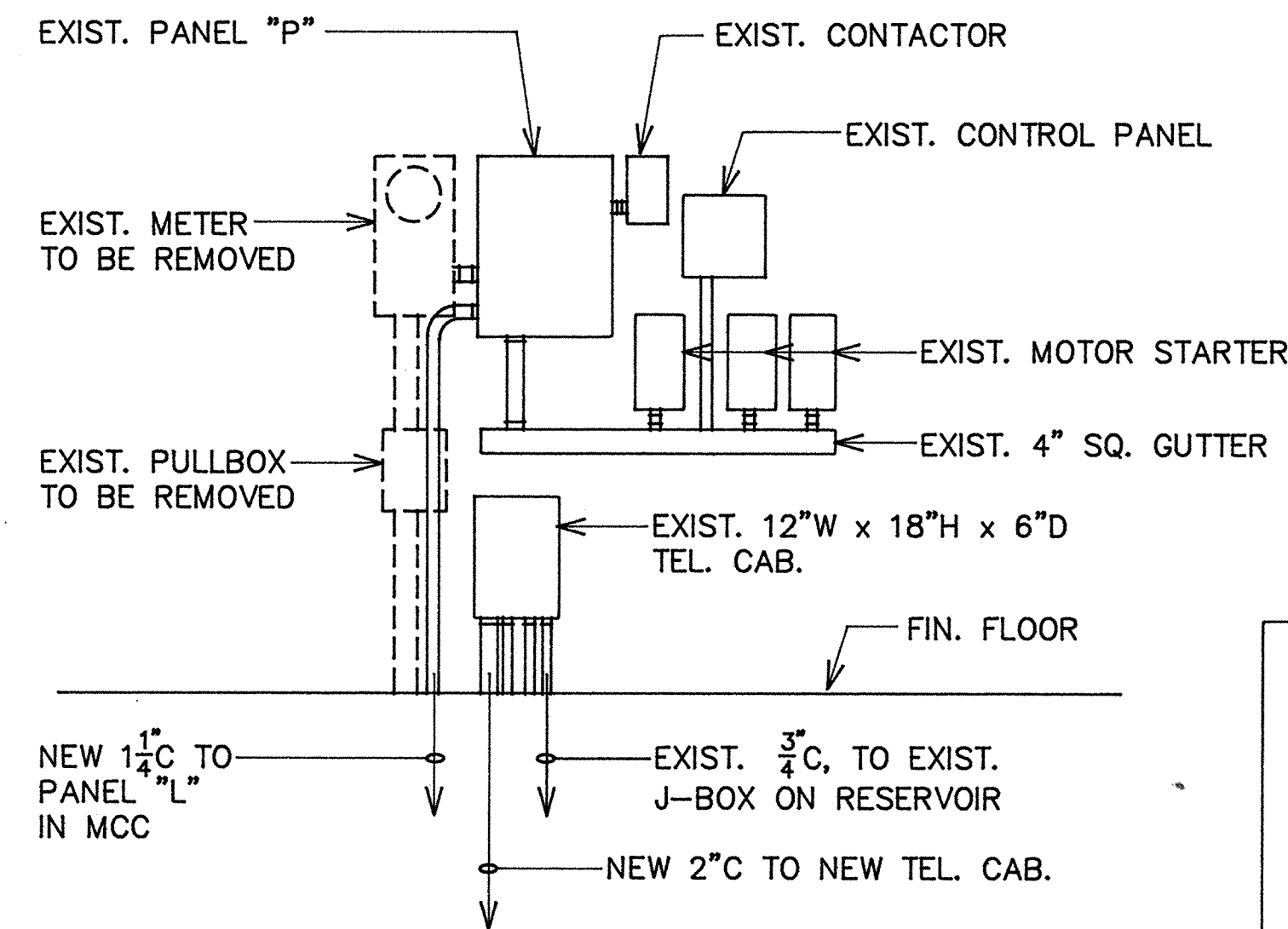

2 EXIST. ELEC. EQUIP. ELEV.

E-4 N.T.S.

- NOTES:
- ALL EQUIPMENT ENCLOSURES SHALL BE TYPE NEMA 3R.
 - * INDICATES PROVISION FOR KECCO SEALS.

E-4

REVISION DATE	DESCRIPTION	R.H.O.	MADE BY	APPROVED
11-23-87	REV. PUMP HP/CKTS.			
AKINAKA & ASSOCIATES, LTD. CONSULTING ENGINEERS				
JOB NO. 85-5				
PUMP, CONTROLS, PUMPHOUSE AND CONNECTING PIPELINE FOR MAKALEHA WELL NO. 0623-04				
KAPAA WATER SYSTEM KAPAA, KAUAI, HAWAII				
ONE-LINE DIAGRAM, SERVICE EQUIPMENT ELEVATION - MAKALEHA WELL				
APPROVED: <i>Raymond H. Goss</i> MANAGER, CHIEF ENGINEER, DEPT. OF WATER SUPPLY				
DATE: 7-1-87				

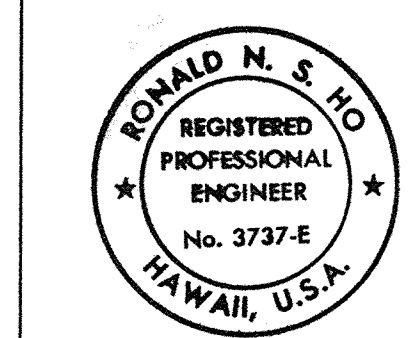

THIS WORK WAS PREPARED BY ME OR UNDER MY SUPERVISION.

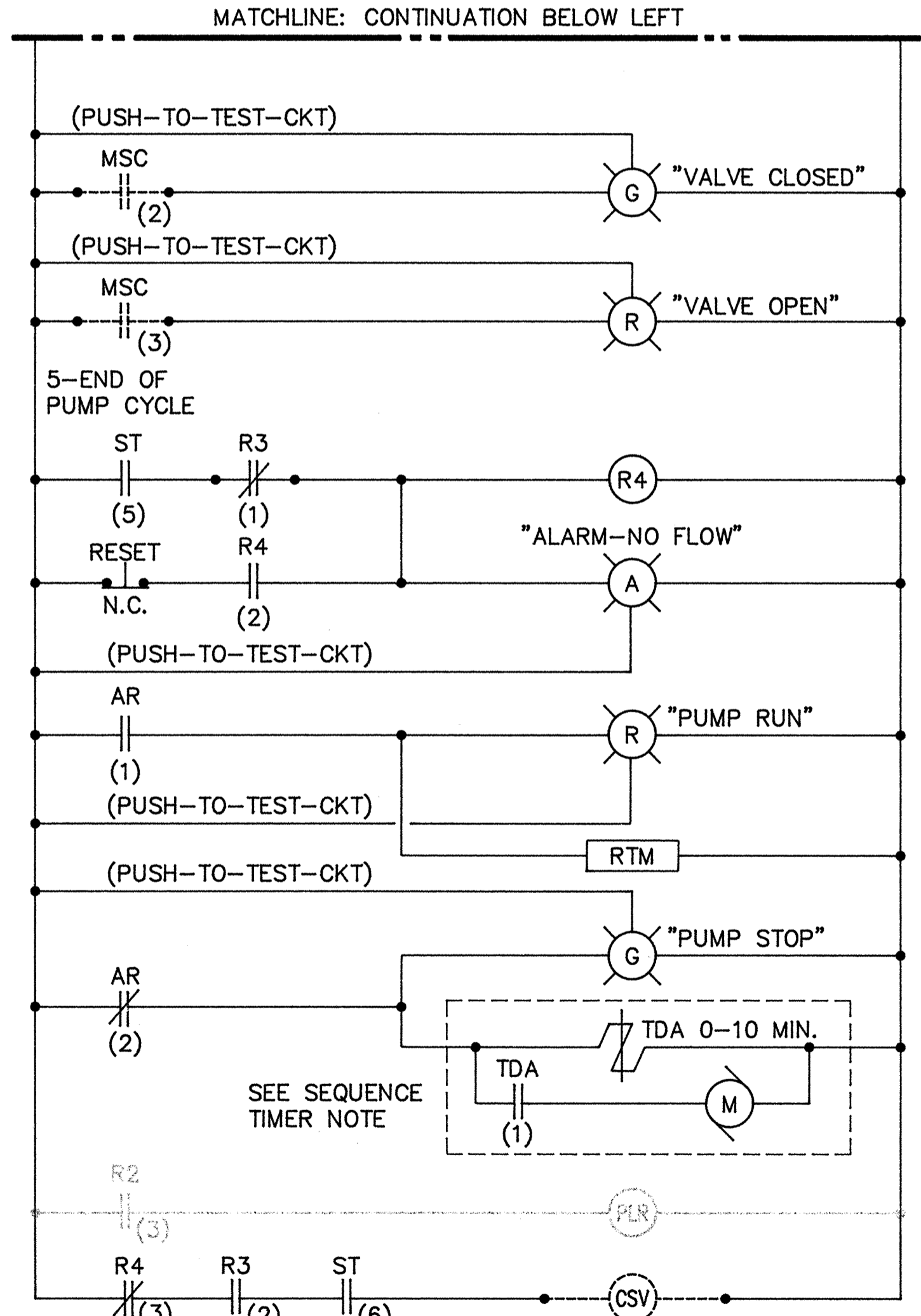
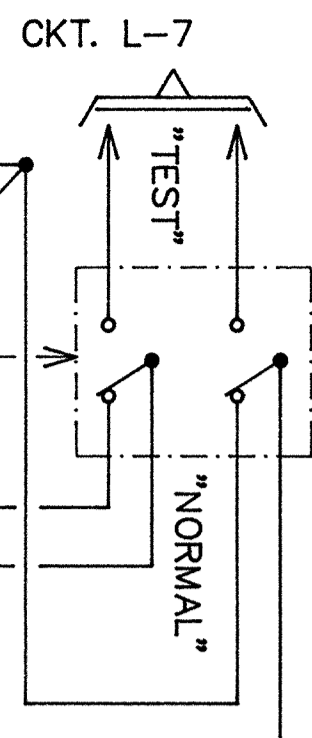
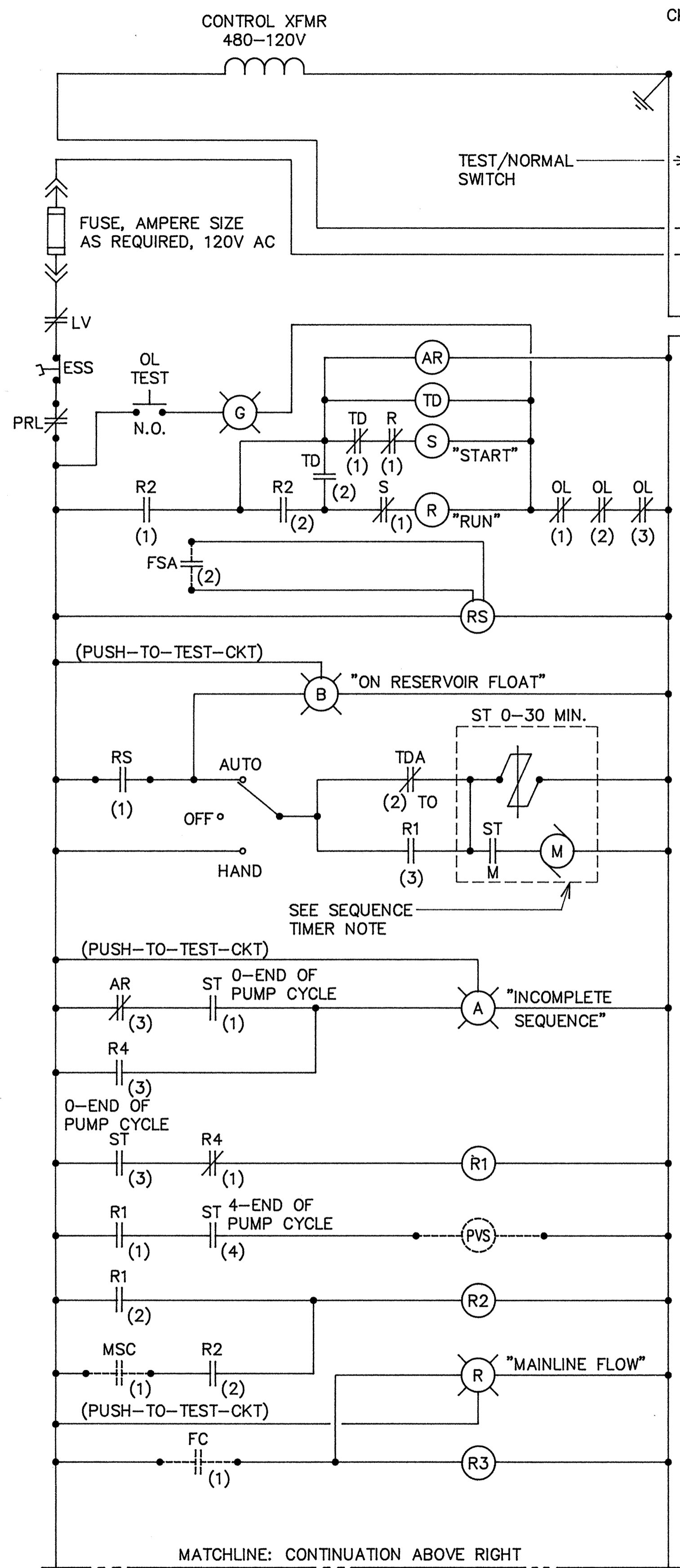

TYPICAL DEEPWELL PUMP CONTROL SEQUENCE

ON START UP, LEVEL CONTROL "FS" CLOSING AND ENERGIZES RELAY "RS", WHICH ENERGIZES TIMER "ST", PROVIDED THE BACKSPIN TIMER "TDA" HAS TIMED OUT FROM THE LAST PUMP CYCLE. "ST(3)" CLOSING ENERGIZING "R1" WHICH STARTS THE PUMP CONTROL VALVE "PVS" AFTER "ST(4)" HAS CLOSED, & ALSO ENERGIZES "R2" WHICH STARTS THE MOTOR. WHEN THE CONTROL VALVE IS CLOSED, THE MICRO-SWITCH "MSC" CLOSING AND HOLDS IN "R2" TO KEEP THE MOTOR RUNNING. IF THERE IS NO WATER FLOW, "FC" WILL NOT CLOSE & THE PUMP WILL STOP THRU "R4", LOCKOUT & LIGHT AN AMBER LIGHT UNTIL RESET. "R3(2)" WILL ENERGIZE THE CHLORINE SOLENOID VALVE AFTER WATER FLOWS & SHUTS DOWN WHEN THE PUMP STOPS, VIA "ST(6)" AND "R3(2)".

ON SHUT DOWN, "FS" OPENS & DE-ENERGIZES "ST" WHICH OPENS "R1" WHICH STARTS THE PUMP CONTROL VALVE OPENING. WHEN "MSC" OPENS, IT OPENS "R2" WHICH STOPS THE PUMP.

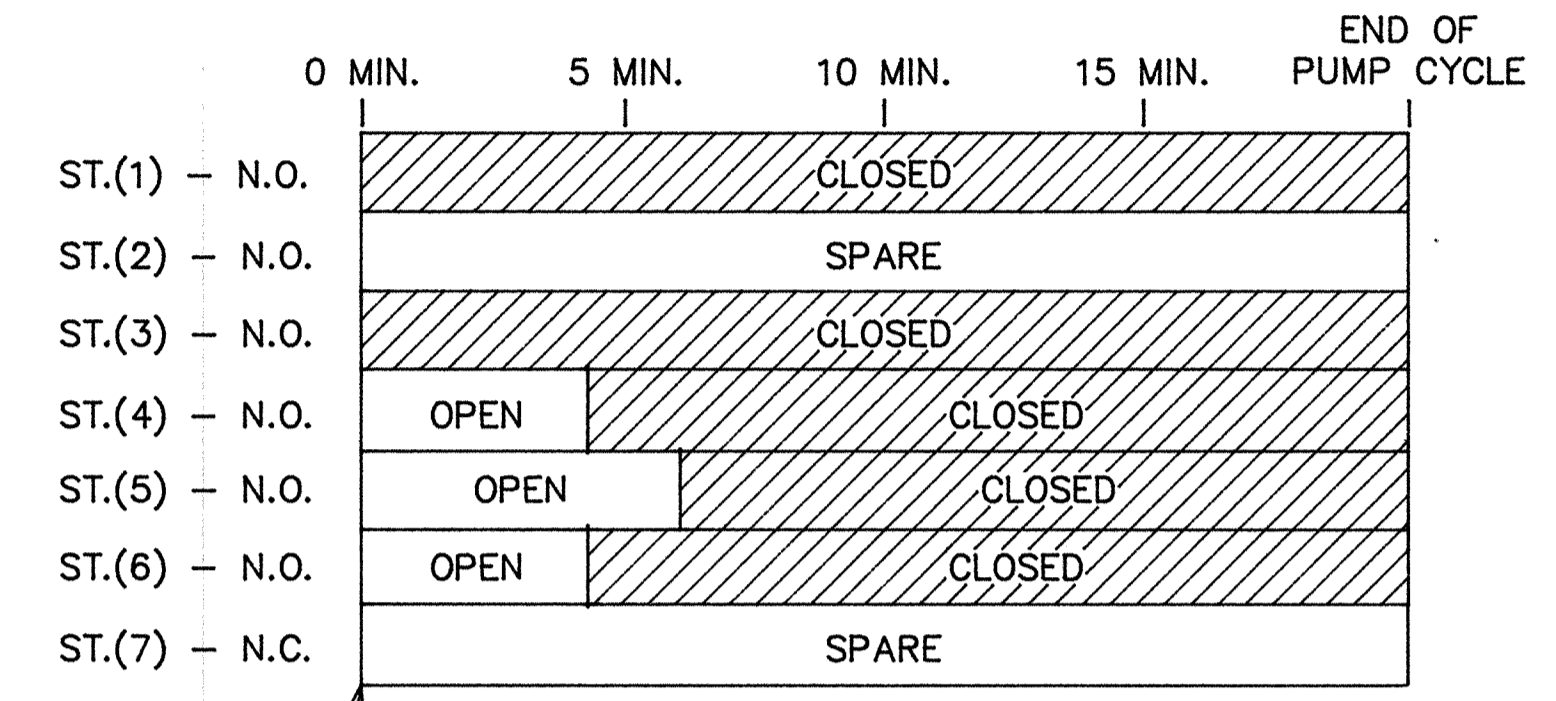

SEQUENCE TIMER BAR GRAPH

SEQUENCE TIMER NOTE:
CONTROL SEQUENCE TIMER & BACKSPIN SEQUENCE TIMER SHALL BE MOUNTED IN A REMOTE CABINET FROM PUMP STARTER CABINETS AND SHALL BE PANEL MOUNTED WITH RUBBER BUSHING TYPE INSULATORS TO ABSORB SHOCKS, JOLTS, ETC. AND STILL OPERATE PROPERLY.

- NOTES:**
- PROVIDE THE FOLLOWING SPARE PARTS:
 - COIL FOR STARTER
 - SET OF ALL MOVING CONTACTS
 - OVERLOAD RELAY & HEATERS
 - BACKSPIN SEQUENCE & CONTROL SEQUENCE TIMER
 - COIL FOR RELAYS (ONE COIL FOR EACH DIFFERENT TYPE RELAY)
 - ONE LAMP & COLORED GLASS FOR EACH INDICATOR LIGHT
 - CKT. BKRS.
 - TIME DELAY RELAYS
 - CONTROL RELAYS

CONTROL SCHEMATIC SYMBOLS

- LV LOW VOLTAGE
- ESS EMERGENCY STOP SWITCH (MANUAL) WITH MANUAL RESET
- OL OVERLOAD
- R1-R4 RELAYS
- ST CONTROL SEQUENCE TIMER
- TDA BACKSPIN SEQUENCE TIMER
- TC TIME CLOCK CONTROL, 7 DAY TYPE WITH MINIMUM 10 HR SPRING CARRYOVER
- PVS CONTROL VALVE SOLENOID
- MSC(1) CONTROL VALVE MICRO-SWITCH, N.C., OPENS WHEN PUMP CONTROL VALVE FULLY CLOSED
- MSC(2) CONTROL VALVE MICRO-SWITCH, N.O., CLOSED WHEN PUMP CONTROL VALVE FULLY CLOSED
- MSC(3) CONTROL VALVE MICRO-SWITCH, N.O., CLOSED WHEN PUMP CONTROL VALVE FULLY OPEN
- FC FLOW SWITCH (CLOSES WITH FLOW)
- RTM RUNNING TIME METER
- (G) GREEN LIGHT - MOTOR STOPPED, OR OVERLOADS WORKING, OR PUMP CONTROL VALVE OPEN
- (R) RED LIGHT - MOTOR RUNNING OR PUMP CONTROL VALVE CLOSED
- (A) AMBER LIGHT - ALARM
- (B) BLUE LIGHT - RESERVOIR DEMAND
- (S) START COIL
- (R) RUN COIL
- FSA FLOAT SWITCH
- RS RESISTANCE SENSITIVE RELAY (CUTLER HAMMER TF RELAY)
- CSV SOLENOID VALVE ON NEW CHLORINE GAS VACUUM LINE
- PLR POST LUBE RELAY (DELAY ON DE-ENERGIZATION ADJUSTABLE 0 - 5 MIN.)
- AR PUMP START AUXILIARY RELAY
- PRL PHASE REVERSAL/LOSS CONTACT

1 DEEPWELL PUMP CONTROL SCHEMATIC
E-6

E-6

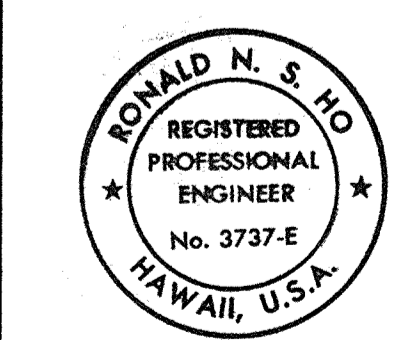

THIS WORK WAS PREPARED BY ME OR UNDER MY SUPERVISION.
Ronald N. S. Ho 5/15/87

REVISION DATE	DESCRIPTION	MADE BY	APPROVED
AKINAKA & ASSOCIATES, LTD. CONSULTING ENGINEERS			
JOB NO. 85-5 PUMP, CONTROLS, PUMPHOUSE AND CONNECTING PIPELINE FOR MAKALEHA WELL NO. 0623-04 KAPAA WATER SYSTEM KAPAA, KAUAI, HAWAII			
DEEPWELL PUMP CONTROL SCHEMATIC - MAKALEHA WELL			
APPROVED: <i>Ronald N. S. Ho</i>			DATE: 7-1-87
MANAGER, CHIEF ENGINEER, DEPT. OF WATER SUPPLY			

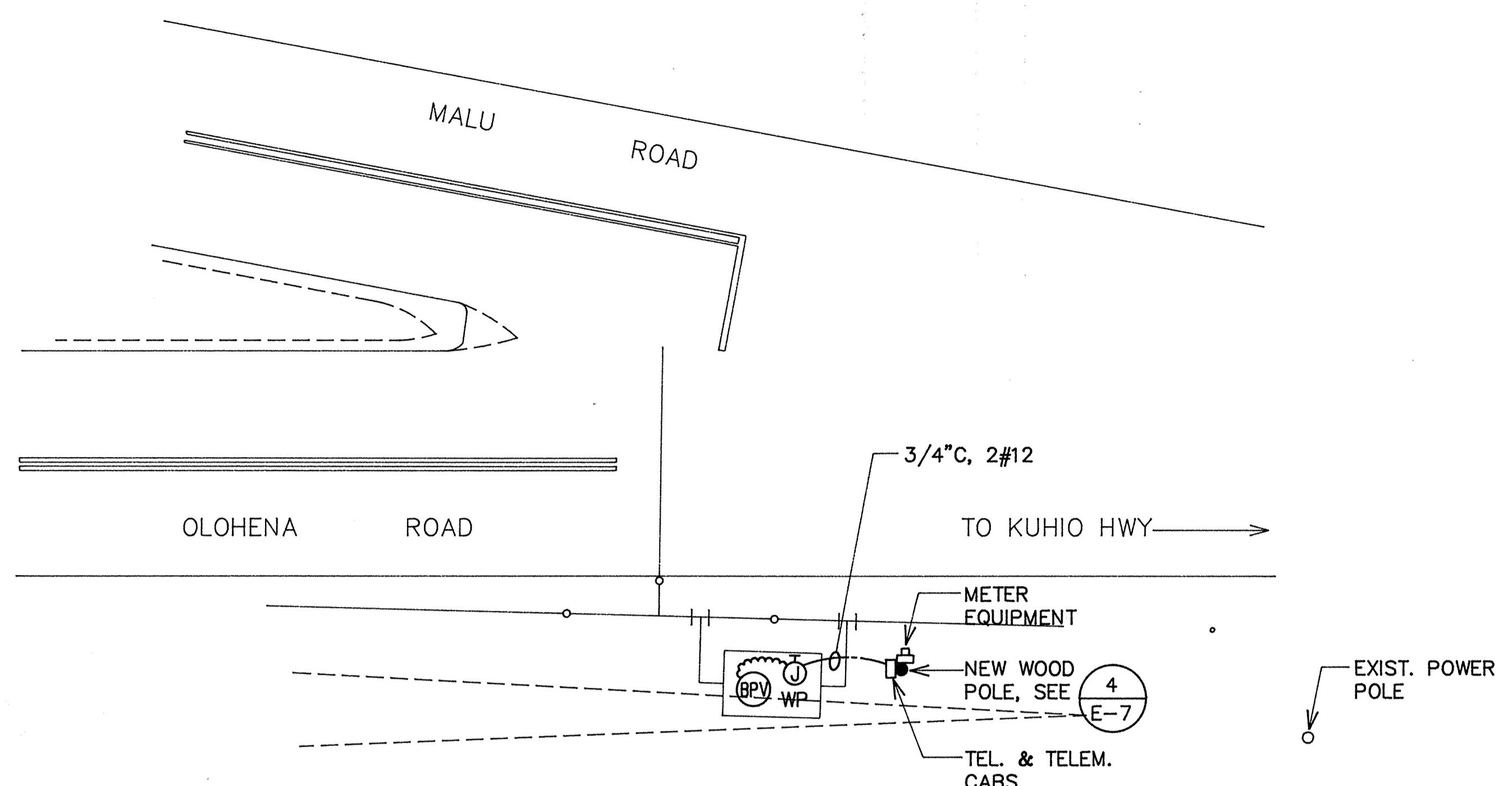

1 BACK PRESSURE VALVE ELEC. PLAN
SCALE: 1"=10'

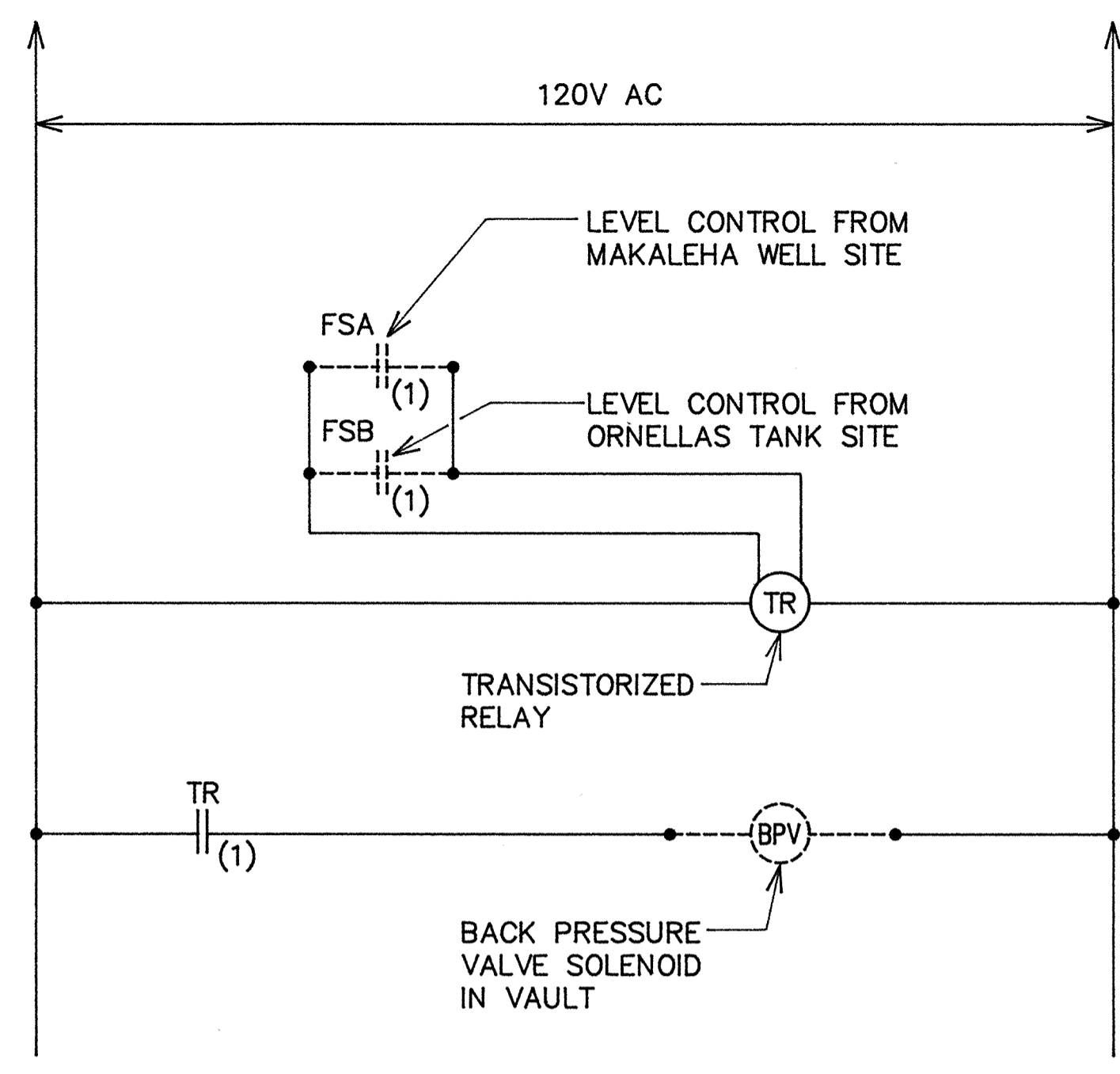

3 NEW BACK PRESSURE VALVE CONTROL DIAGRAM
N.T.S.

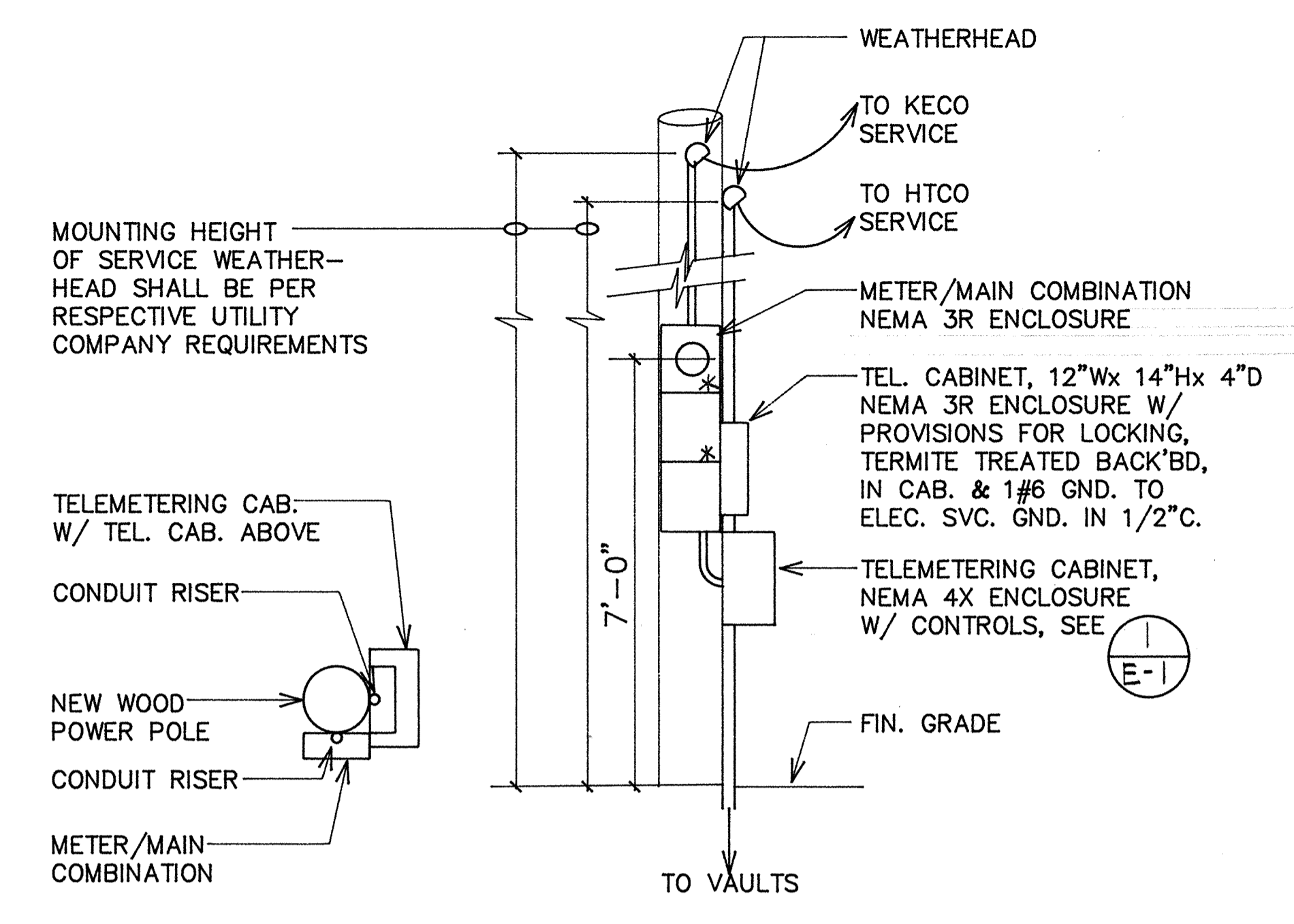

4 POLE DETAIL
N.T.S.

- NOTES
- * INDICATES PROVISION FOR KECO SEALS.
 - ALL CABINETS SHALL HAVE PROVISION FOR ~~DOOR~~ PADLOCKS.

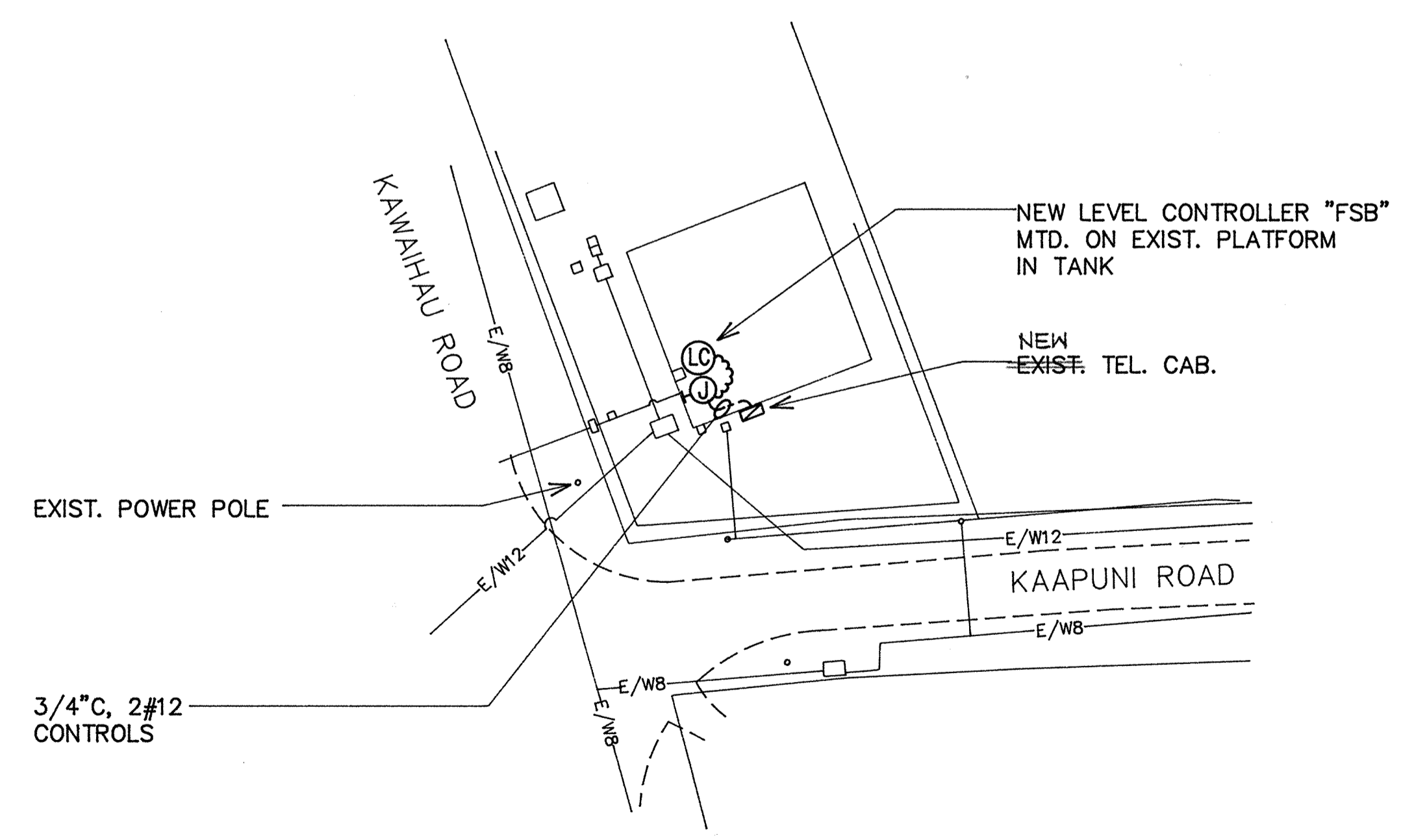

2 ORNELLAS TANK SITE ELEC. PLAN
SCALE: 1"=40'

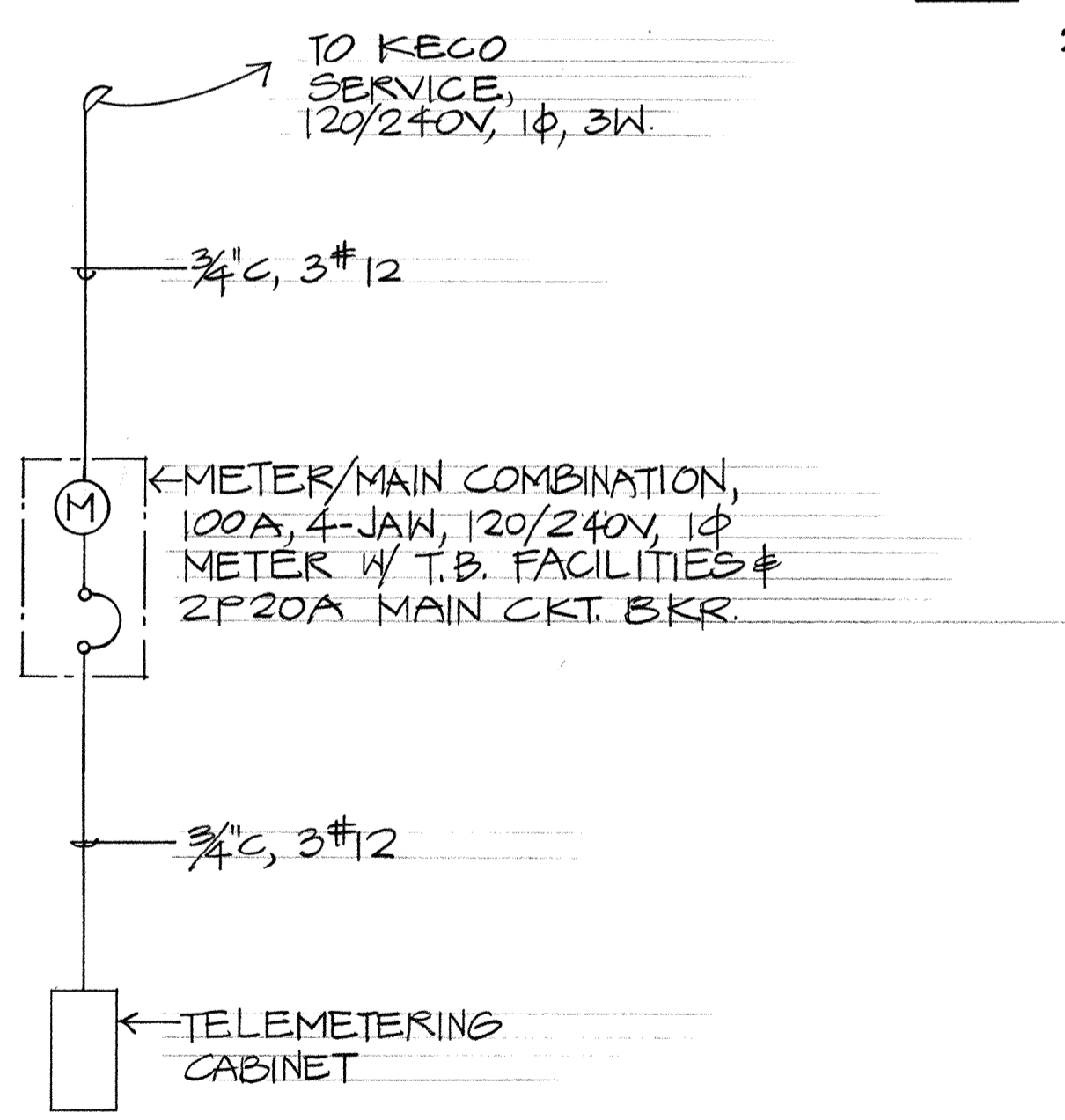

ONE-LINE DIAGRAM
BACKPRESSURE VALVE SITE

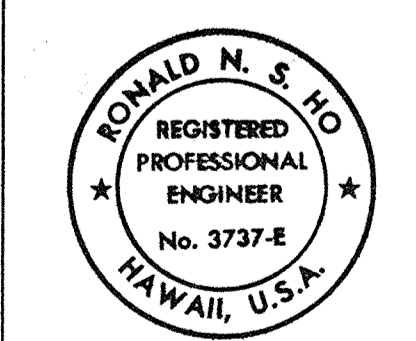

THIS WORK WAS PREPARED BY ME OR UNDER MY SUPERVISION.
Ronald N. S. Ho

REVISION DATE	DESCRIPTION	MADE BY	APPROVED
AKINAKA & ASSOCIATES, LTD. CONSULTING ENGINEERS JOB NO. 85-5 PUMP, CONTROLS, PUMPHOUSE AND CONNECTING PIPELINE FOR MAKALEHA WELL NO. 0623-04 KAPAA WATER SYSTEM KAPAA, KAUAI, HAWAII			
BACK PRESSURE VALVE ELEC. PLAN, ORNELLAS TANK SITE ELEC. PLAN, POLE DETAIL - MAKALEHA WELL			
APPROVED: <i>Ronald N. S. Ho</i> MANAGER, CHIEF ENGINEER, DEPT. OF WATER SUPPLY			7-1-87 DATE

E-7